

KIT PRODUCT CATALOG

003	INTRODUCTION
012	CONTENTS
020	OSSTEM KIT
170	User Manual

Providing cutting edge technology and superior quality

Making products that dentists want to use, trust, and are satisfied with :
This is our mission at **OSSEM IMPLANT**



**We are forever grateful
to all the dentists
who have given
unwavering support to
OSSTEM IMPLANT**

Thank you for using Osstem Implant. Osstem, Korea's first implant manufacturer, has secured world-class implant competitiveness through continuous R&D investment and quality innovation. It has grown to become Asia-Pacific No.1 and World No.5 Implant Company. In addition to dental implants and treatment tools, we are leading the development of products that are essential for dentists, including dental equipment, dental materials, and dental IT, and contribute to the development of the dental industry. The comprehensive catalog of the 2018-19 product series published here shows Osstem's technology-rich products. We have focused on catalog structure so that it is convenient to browse and order products. In particular, in the case of fixtures, abutments, and surgical tools, we introduced the diameter, length, and functions in detail.

GBR products are also easy to order by type, size and capacity. In addition, the product release date and time are displayed so that customers can understand when the existing product is released and what the newly released product is. We also introduced the CAD/CAM product in terms of preparing the digital dentistry, a major trend in the dentistry. In terms of design, we also implemented high-quality images of representative products by specification. By applying representative colors for each product system, it is easy to sort by category. We hope this will help you effectively find and purchase the products you need from the dental clinic of 2018-19. Osstem Implant will continue to develop products that the dentist can trust. We will work to create greater customer value. Thank you.

CEO of OSSTEM IMPLANT
Choi Kyu-ok (DDS.Ph.D)

Handwritten signature of Choi Kyu-ok in black ink.

Worldwide & History

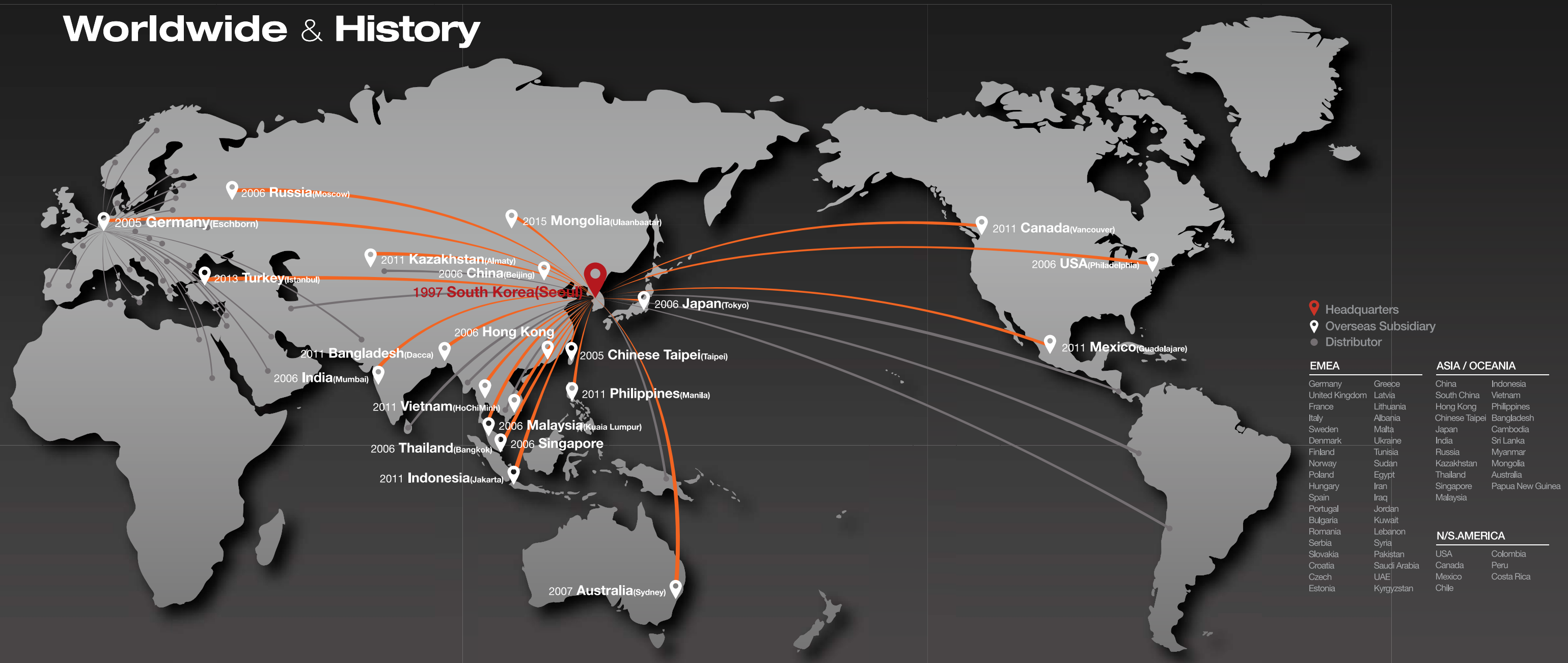

1997

- 01 Established 'Osstem Co., Ltd.'
- 12 Released 'Doobunae' (health insurance claim application software program)

2001

- 01 Obtained CE-0434 certification
- 03 Established AIC training center

2006

- 03 Changed the company name to Osstem Implant Co., Ltd
- 04 Obtained GOST-R certification (russia)
- 12 Established 12 overseas branches (first round)

2008

- 01 Established osstem bone science research center
- 12 Selected as a managing organization for the national strategic technology development project

2010

- 03 Launched TSIII SA line
- 06 Launched TSIII HA line

2012

- 06 Launched TSIII CA line
- 07 Established osstem dental equipment research institute

2014

- 05 Selected as 'World Class 300'
- 05 Released 'HyFlex', an impression material
- 08 Released 'BeauTis' whitening material

2016

- 01 Established Vussen Co., Ltd.
- 03 Acquired Cardiotec Co., Ltd.
- 08 Acquired Hubit Co., Ltd.
- 11 Launched OneGuide system

2000

- 06 Released 'Hanaro' (dentistry management software)
- 10 Acquired sumin comprehensive dental materials

2002

- 01 Established Osstem Implant R&D center
- 08 Obtained FDA certification, launched USII line
- 10 Launched SSII line

2007

- 02 Listed on KOSDAQ and began trading publicly
- 06 Selected as No.1 products for the next generation and obtained TGA certification (australia)

2009

- 10 Obtained approval for medical device manufacturing and sale from the ministry of health, labor and welfare, japan

2011

- 06 Osstem Implant R&D center was selected as ATC (advanced technology center)
- 07 Selected as 'World Champ' business
- 12 Launched 'K2 unit chair', which was selected as a 'World Class Product'

2013

- 01 Launched osstem xenograft material 'A-Oss'
- 09 Launched 'K3 unit chair'
- 10 Selected as a 'Hidden Champion' company

2015

- 03 Established Osstem BioPharma Co., Ltd.
- 12 Awarded 'USD 50 Million Export Tower'

2017

- 12 2017 presidential commendation for job creation

2018

- 01 TS exceeded 10 million production

OSSTEM[®] Implant Design feature

OSSTEM IMPLANT has revolutionized implant dentistry in South Korea. With a focus on aggressive R&D, a commitment to education and a dedication to manufacturing the best products, Osstem Implant's ultimate goal is to become the global leader in implant dentistry.

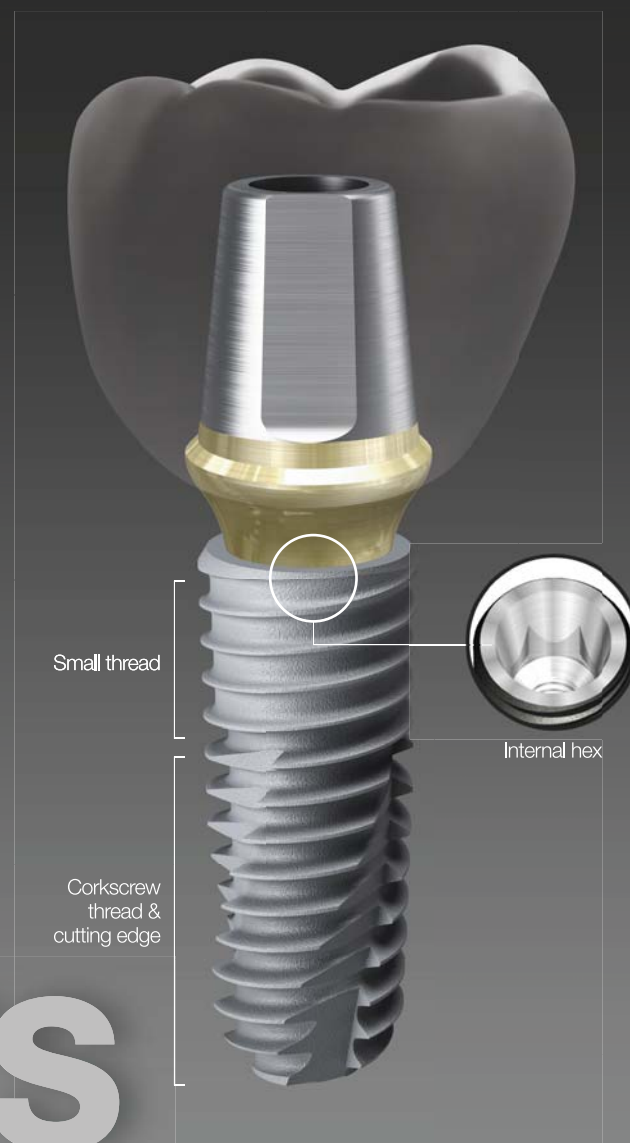

TS



SS



US

Submerged type implant with an internal hex and 11 tapered connection

- Internal connection type - Mini / Regular
- Excellent initial stability in soft bone due to smaller threads in the upper section
- Corkscrew thread with cutting edges
 - Strong self-threading effect for easy fixture path
 - Higher initial stability and consistent insertion torque
- Different body types to properly match the patient's bone quality and clinical condition
 - TSII (straight body) : easy to adjust depth
 - TSIII (1.5° tapered body) : excellent initial stability necessary for immediate loading, even in soft bone
 - TSIV (6° tapered body) : specifically designed for the maxillary sinus and soft bone, excellent initial stability
- Available surface types - SA / CA / HA / BA / SOI

Non-submerged type implant with an internal octa and 8 tapered connection

- Internal connection type - Regular / Wide
- Corkscrew thread with cutting edges
 - Strong self-threading effect for easy fixture path
 - Higher initial stability and consistent insertion torque
- Different body types to properly match the patient's bone quality and clinical condition
 - SSII (straight body) : easy to adjust the insertion depth
 - SSIII (1.5° tapered body) : excellent initial stability necessary for immediate loading, even in soft bone
- Available surface types - SA / CA / HA / BA

Submerged type implant with an external hex connection structure

- Internal connection type - Mini / Regular / Wide / Wide PS
- Corkscrew thread with cutting edges
 - Strong self-threading effect for easy fixture path
 - Higher initial stability and consistent insertion torque
- Different body types to properly match the patient's bone quality and clinical condition
 - USII (straight body) : easy to adjust the insertion depth
 - USIII (1.5° tapered body) : excellent initial stability necessary for immediate loading, even in soft bone
 - USIV (6° tapered body) : specifically designed for the maxillary sinus and soft bone, excellent initial stability
- Available surface types - SA / CA



Each implant system has its own unique color code

OSSTEM[®] Implant Surface feature

The key factor in providing implant treatment safely and efficiently is surface technology.

OSSTEM IMPLANT is proud of its cutting-edge surface technology.

SA CA HA BA SOI

Acid Treated Optimized Surface

- Ra 2.5~3.0 μ m surface roughness (note : the upper 0.5mm part of the implant has Ra 0.5~0.6 μ m)
- Consistent surface micro pits between 1 to 3 μ m
- Surface area is increased by 46 percent compared to RBM treated implants

In-vitro & In-vivo Bone Response

- 20% improvement in osteoblast separation and ossification compared to RBM
- Initial bone reaction performance in animal model (mini-pig)
 - 48% improvement in initial stability (RT, 4 weeks) compared to RBM
 - 20% improvement in ossification (BIC, 4 weeks) compared to RBM

Super-hydrophilic SA surface suspended in a calcium solution

- Same SA surface morphology
- Optimizing surface reaction by suspension in a calcium (CaCl₂) solution
- Increased new bone formation area due to the excellent blood wettability
- Bone response improved in early osseointegration stage compared to standard SA surface

In-vitro & In-vivo Bone Response

- Protein and cellular adhesion tripled compared to SA surfaces
- Initial cellular differentiation by 19 percent compared to SA surfaces (7 days)
- Initial stability increased by 34 percent compared to SA surfaces (RT at 4 weeks)
- Ossification rate Increased by 26 percent compared to SA surfaces (BIC at 4 weeks)

Premium high-crystalline HA-coated surface

- 30 to 60 μ m thick high-crystalline HA coating
- HA coated onto a RBM surface (Ra 3.0 to 3.5 μ m)
- High HA crystalline over 98 percent
- Solved the problem with low-crystalline HA resorption

In-vitro & In-vivo Bone Response

- Excellent biocompatibility in HA that is similar to bone
- Initial ossification by osteoblasts doubled compared to SA surfaces (5 days)
- 40% improvement in initial stability (RT, 4 weeks) in animal models compared to SA
- Suitable for poor bone quality, tooth extraction sites or immediate implant insertion

Premium low crystalline nano-HA coated SA surface

- SA surface (Ra 2.5 to 3.0 μ m) coated with HA
- 10nm ultra-thin HA coating
- Dual function between titanium and HA
 - HA is naturally resorbed during ossification

In-vitro & In-vivo Bone Response

- Advantages of both SA and HA surfaces
 - SA's ability to maintain an optimal surface
 - HA's ability to form high quality initial bone, even in a poor bone quality
- 40% improvement in ossification (BIC) compared to SA
- It is applicable to all types of bone quality











































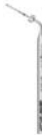





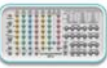



















Next-generation surface coated with special material (K material)

- Activation of blood clot formation
- Avoid carbon adsorption in air
- Coating of K material on SA surface (Ra 2.0~3.0 μ m)
- Superior blood wettability with super hydrophilic surface.







































































In-vitro & In-vivo Bone Response

- Protein and cellular adhesion 130 times increase compared to SA surface
- Initial stability increased by 57 percent compared to SA surfaces (RT at 4 weeks)
- Surface with the shortest duration of surgery























































KIT Contents 1/3

020 One Guide KIT 	021 Initial Drill 	021 Flattening Drill 	022 Tissue Punch 	022 OneGuide Drill 	047 Guide Pin 	048 122 Taper KIT 	049 122 Taper Full KIT 	050 122 Taper Drill 	050 Cortical Drill for Ultra-Wide 
023 NoMount Driver 	024 Fixture Driver 	024 Anchor Screw 	024 Anchor Drill 	025 Anchor Driver 	051 Parallel Pin for 122 Taper Drill 	058 Taper KIT 	059 Taper Ultra KIT 	060 Taper Drill 	060 Taper Cortical Drill for Taper Fixture 
025 NoMount Driver for SS 	025 Fixture Driver for SS 	026 NoMount Driver for US 	026 Fixture Driver for US 	036 One CAS KIT 	061 Taper Ultra Drill 	061 Cortical Drill for Ultra-Wide 	061 Parallel Pin for Taper Drill 	062 Tapered Fixture Tap for TSIII, USIII, SSIII SA 	070 123 Straight Simple KIT 
037 OneCAS Ø2.2 Twist Drill 	037 OneCAS Drill 	038 OneCAS Stopper 	039 Depth Gauge 	040 Parallel Guide KIT 	071 123 Twist Drill 	071 123 Drill Stopper 	072 123 Cortical Drill 	074 123 Straight KIT 	075 123 Straight Full KIT 
041 Parallel Guide Full KIT 	042 Guide Drill 	042 Single Guide 	042 Guide Pin 	043 Bridge Guide 	076 123 Twist Drill - Stopper Drill 	076 123 Ultra Twist Drill 	077 123 Cortical Drill 	077 Parallel Pin for 123 Drill 	077 Trial Pin for Ultra- wide 
043 Multi Joint Handle 	043 Denture Guide 	044 L-wrench 	044 Distance Setup Pin 	045 Smart Guide KIT 	084 New Hanaro KIT 	086 Twist Drill - Stopper Drill 	086 Twist Drill - Non Stopper Drill 	087 Long Shank Pilot Drill 	087 Cortical Drill 2 for TSII, SSII SA 
046 Smart Guide 	046 Twist Drill 	046 X Sleeve 	047 Round Bur 	047 Ø2.2 Twist Drill 	087 Cortical Drill 3 for Taper Fixture 	087 Countersink for USIII, USII SA, USIII SA 	088 Straight Fixture Tap for TSII, USII, SSII SA 	088 Parallel Pin 	090 Ultra KIT 

KIT Contents 2/3

091 Direct Drill 	091 Cortical Drill for Ultra-Wide 	091 Trial Pin for Ultra-wide 	102 485 KIT 	103 485 Drill 	115 Bone Mill 	116 Anterior Hand Driver for Implant 	116 Torque Handle 	118 Prosthetic Simple KIT 	119 Prosthetic KIT 
106 123 Guide Drill 	106 Lance Drill - Guide Drill 	106 Sidecut Drill 	107 Drill Extension 	107 NoMount Driver for TS 	120 Hand Driver 	120 Machine Screw Driver 	121 Torque Driver 	121 Angled Torque Driver 	121 Repair Torque Driver 
107 NoMount Driver for SS 	108 NoMount Driver for US 	108 NoMount Torque Driver for TS 	108 NoMount Torque Driver for SS 	109 Fixture Driver for TS 	122 Solid Abutment Driver 	122 O-ring Abutment Driver 	122 Rigid Outer Driver 	123 Excellent Solid Abutment Driver 	123 Octa Abutment Driver 
109 Fixture Driver for SS 	109 Fixture Driver for US 	110 Torque Extension 	110 Simple Mount Driver 	110 Simple Mount Extension 	124 Multi Abutment Machine Driver 	124 Abutment Holder 	124 Multi Abutment Outer Driver 	124 Locator® Torque Driver 	125 Osstem Torque Driver 
110 Simple Open Wrench 	111 Removal Tool for Fixture Mount 	111 Depth Gauge 	111 Positioning Guide 	111 Tissue Height Gauge for TS 	125 Path Probe for TS 	125 Torque Connector 	126 Machine Driver Connector 	126 Driver Handle 	126 Finishing Reamer Set 
112 Ratchet Wrench 	112 L-Wrench 	112 Torque Wrench - Spring Type 	112 Torque Wrench - Bar Type 	113 Torque Wrench Set 	127 Reamer Bite 	127 Reamer Tip for Rigid Abutment 	127 Reamer Tip for Solid, Excellent Solid Abutment 	128 CAS KIT 	129 CAS Drill 
113 Tissue Punch 	114 TS Bone Profiler 	114 US Bone Profiler 	115 Trepine Drill 	115 Machine Driver Handle 	129 Guide Drill 	129 Ø 2.2 Twist Drill 	130 Hydraulic Membrane Lifter Set 	130 Stopper 	130 Bone Carrier 

KIT Contents 3/3

130 Bone Carrier Head 	131 Bone Condenser 	131 Hydraulic Membrane Lifter Tube 	131 Membrane Lifter 	132 Depth Gauge 	150 Slot Driver 	150 Transfer Abutment Separate Tool 	152 EFR KIT 	153 EFR Full KIT 	154 Remove Screw 
132 Bone Spreader 	132 Y-Connector 	134 LAS KIT 	135 Dome Drill 	135 Core Drill 	156 Screw Driver 	156 Remove Body 	156 Torque Extension 	157 Torque Wrench 	157 Fixture Wrench 
135 Side Wall Drill 	136 Bone Separator 	136 Stopper 	138 ESSET KIT 	139 Crest Remover 	158 Dr.Cho's instrument KIT 	159 Osstem Basic instrument KIT 	162 Custom KIT 	164 Osteo KIT 	165 Osteotome KIT 
139 Twist Drill 	139 Saw 	140 Expansion Drill 	140 Mount Extension 	140 EXP Mount Driver 	166 Sinus KIT 	167 Bone Spreader KIT 	168 Ridge Split KIT Straight 	169 Ridge Split KIT Offset 	
141 Saw Protector 	141 Torque Wrench 	141 Depth Gauge 	142 ESR KIT 	143 ESR Full KIT 					
144 Guide 	147 Reverse Drill 	147 Screw Removal Drill (SR Drill) 	147 Torque Driver Handle 	148 Reverse Driver 					
148 Screw Removal Tip (SR Tip) 	148 Screw Holder 	149 Re-tap 	149 ESR Handle 	149 Abutment Removal Tip (AR Tip) 					

OSSTEM[®]
IMPLANT

OSSTEM KIT

- | | | | |
|------------|-------------------------|------------|-----------------------------|
| 020 | OneGuide KIT | 128 | CAS KIT |
| 036 | OneCAS KIT | 134 | LAS KIT |
| 040 | Parallel Guide KIT | 138 | ESSET KIT |
| 041 | Parallel Guide Full KIT | 142 | ESR KIT |
| 045 | Smart Guide KIT | 143 | ESR Full KIT |
| 048 | 122 Taper KIT | 152 | EFR KIT |
| 049 | 122 Taper Full KIT | 153 | EFR Full KIT |
| 058 | Taper KIT | 158 | Dr.Cho's Instrument KIT |
| 059 | Taper Ultra KIT | 159 | Osstem Basic Instrument KIT |
| 070 | 123 Straight Simple KIT | 162 | Custom KIT |
| 074 | 123 Straight KIT | 164 | Osteo KIT |
| 075 | 123 Straight Full KIT | 165 | Osteotome KIT |
| 084 | New Hanaro KIT | 166 | Sinus KIT |
| 090 | Ultra KIT | 167 | Bone Spreader KIT |
| 102 | 485 KIT | 168 | Ridge Split KIT Straight |
| 118 | Prosthetic Simple KIT | 169 | Ridge Split KIT Offset |
| 119 | Prosthetic KIT | | |

OneGuide KIT (OOGK)



OneGuide KIT Surgical Instruments

For **TSIII / IV** **SSIII** **USIII**

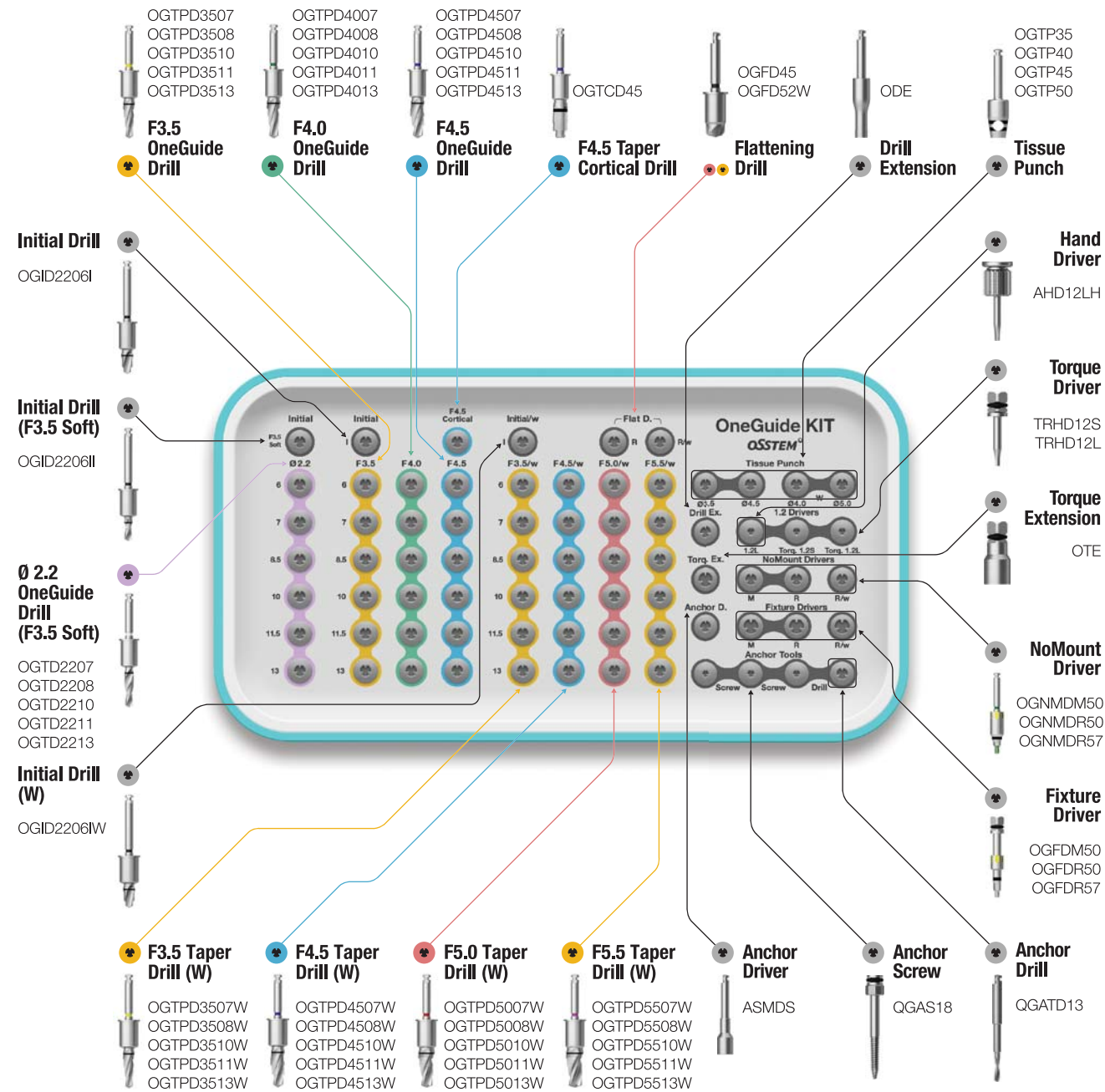

OneGuide

- There are open type and close type
 - The open type can be used in the molar with restricted opening
- It consists of 2 guide holes according to the diameter of the fixture
 - D5.1 : F3.5/4.0/4.5
 - D5.8 : F5.0
- Dual contact function ensures excellent positioning accuracy
- Simple drilling sequence by using 122 taper KIT drill
- Packing unit : surgical guide (option : OneFit abutment, temporary crown)



Initial Drill

- Selection of location after using tissue punch
- Securing the guide depth of the following drill
- 3 types (F3.5 soft / below F4.5 / for F5.0)

For F3.5 Soft
For below F4.5
For F5.0

OGID2206II
OGID2206I
OGID2206IW

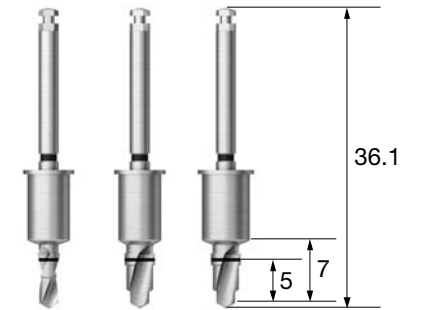

Flattening Drill

- Used for narrow or uneven ridges
- There are a lot of cutting edges, so it is stably removed without bouncing
- 2 types (below F4.5 / for F5.0)

D	Ø4.5	Ø5.2
For Below F4.5	OGFD45	-
For F5.0	-	OGFD52W

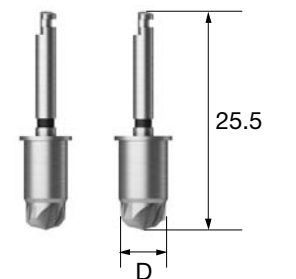

OneGuide KIT Surgical Instruments

Tissue Punch

- It is used to remove gingiva
- Marking line at 1mm intervals according to gingival height
- 2 types of each (for below F4.5 / for F5.0)

For below 4.5	OGTP35	OGTP45
For F5.0	OGTP40	OGTP50

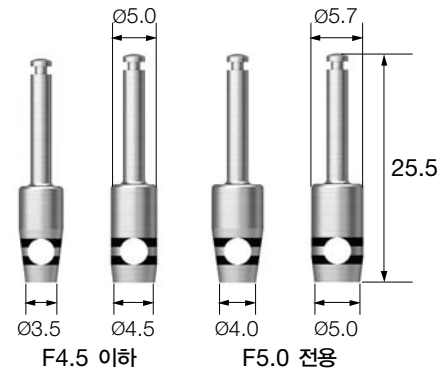

For below F4.5

L	TL	F3.5	F4.0	F4.5	F4.5 Cortical
	Y-Dim	0.7	0.9	1.0	-
	GD	5.0	5.0	5.0	5.0
6	36.1	OGTPD3506	OGTPD4006	OGTPD4506	-
7	36.1	OGTPD3507	OGTPD4007	OGTPD4507	-
8.5	36.1	OGTPD3508	OGTPD4008	OGTPD4508	-
10	36.1	OGTPD3510	OGTPD4010	OGTPD4510	OGTCD45
11.5	37.6	OGTPD3511	OGTPD4011	OGTPD4511	-
13	39.1	OGTPD3513	OGTPD4013	OGTPD4513	-

OneGuide Drill

- Optimized taper drill for III/IV type fixture (F3.5~5.0, 6~13mm fixture can be placed)
- Stable drilling with multistage structure
- 3 types (for F3.5 soft / below F4.5 / F5.0)
- Use of F4.5 cortical drill for F4.5 fixture hard bone surgery

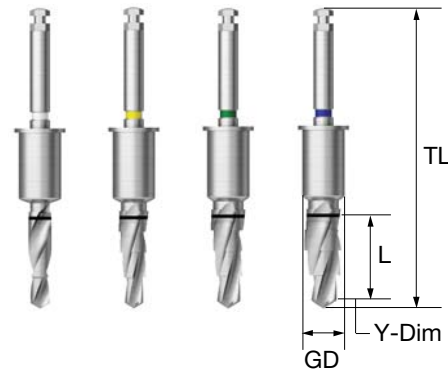

For F5.0

L	TL	F3.5(w)	F4.5(w)	F5.0(w)	F5.5(w)
	Y-Dim	0.7	0.9	1.0	1.0
	GD	5.7	5.7	5.7	5.7
6	36.1	OGTPD3506W	OGTPD4506W	OGTPD5006W	OGTPD5506W
7	36.1	OGTPD3507W	OGTPD4507W	OGTPD5007W	OGTPD5507W
8.5	36.1	OGTPD3508W	OGTPD4508W	OGTPD5008W	OGTPD5508W
10	36.1	OGTPD3510W	OGTPD4510W	OGTPD5010W	OGTPD5510W
11.5	37.6	OGTPD3511W	OGTPD4511W	OGTPD5011W	OGTPD5511W
13	39.1	OGTPD3513W	OGTPD4513W	OGTPD5013W	OGTPD5513W

F3.5 Soft Bone

L	TL	Ø2.2
	Y-Dim	0.7
	GD	5.0
7	36.1	OGTD2207
8.5	36.1	OGTD2208
10	36.1	OGTD2210
11.5	37.6	OGTD2211
13	39.1	OGTD2213

NoMount Driver

- Used when placing a nomount fixture
- ※ It is recommended that 80% of the planned fixture depth be placed
- C = Connection

	C	Mini(Ø5.0)	Regular(Ø5.0)	Regular(Ø5.7)
F3.5	OGNMDM50	-	-	-
F4.0 / 4.5	-	OGNMDR50	-	-
F5.0	-	-	-	OGNMDR57

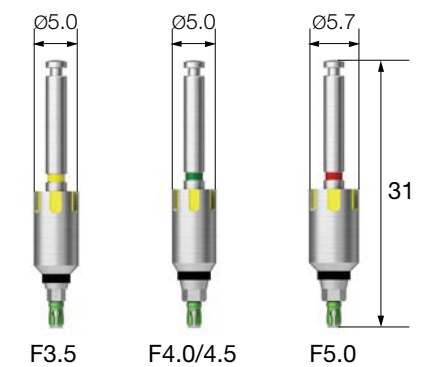

OneGuide KIT Surgical Instruments

Fixture Driver

- It is used by tightening to the wrench for the adjustment of the final placement
- Form a yellow groove to align the abutment hex direction
- Match the groove of OneGuide with the groove of driver
- C = Connection

C	Mini(Ø5.0)	Regular(Ø5.0)	Regular(Ø5.7)
F3.5	OGFDM50	-	-
F4.0 / 4.5	-	OGFDR50	-
F5.0	-	-	OGFDR57

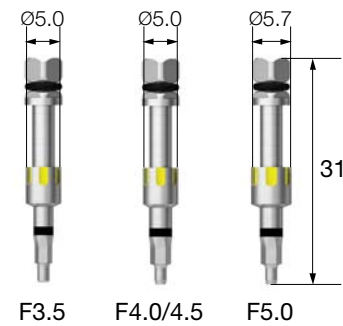

Anchor Driver

- Used by tightening to anchor screw

ASMDS



Anchor Screw

- It is used to fix OneGuide firmly
- Selectable at the planning stage

QGAS18



NoMount Driver for SS

- Used for SSIII NoMount fixture placement
- It is recommended that 80% of the planned fixture depth be placed
- P = Platform

P	Regular(Ø5.0)	Regular(Ø5.7)
F3.5 / 4.0 / 4.5	OGNMDR50S	-
F5.0	-	OGNMDR57S

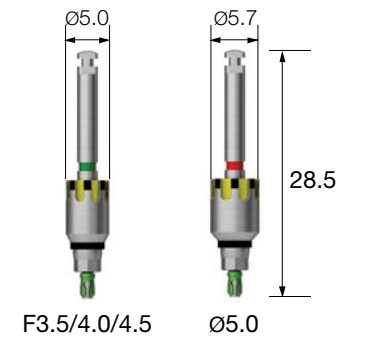

Anchor Drill

- Used for drilling before using anchor screw

QGATD13



Fixture Driver for SS

- It is used by tightening to the wrench for the adjustment of the final placement
- SSIII G/H 2.8 fixture is implanted to the bottom of the driver's marking line
- Form a yellow groove to align the abutment hex direction
- Match the groove of OneGuide with the groove of driver
- P = Platform

P	Regular(Ø5.0)	Regular(Ø5.7)
F3.5 / 4.0 / 4.5	OGFDR50S	-
F5.0	-	OGFDR57S

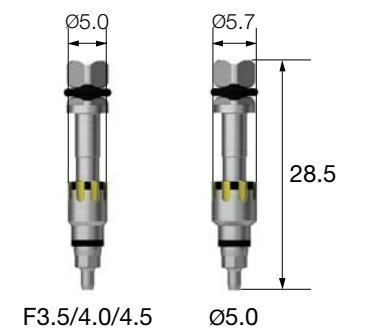

OneGuide KIT Surgical Instruments

NoMount Driver for US

- Used for USIII NoMount fixture placement
- It is recommended that 80% of the planned fixture depth be placed
- P = Platform

	P	Mini(Ø5.0)	Regular(Ø5.0)	Wide(Ø5.7)
F3.5	OGNMDM50U	-	-	-
F4.0 / 4.5	-	OGNMDR50U	-	-
F5.0	-	-	OGNMDW57U	-

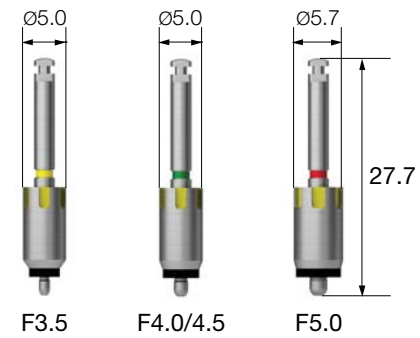

Fixture Driver for US

- It is used by tightening to the wrench for the adjustment of the final placement
- Form a yellow groove to align the abutment hex direction
- Match the groove of OneGuide with the groove of driver
- P = Platform

	P	Mini(Ø5.0)	Regular(Ø5.0)	Wide(Ø5.7)
F3.5	OGFDM50U	-	-	-
F4.0 / 4.5	-	OGFDR50U	-	-
F5.0	-	-	OGFDW57U	-

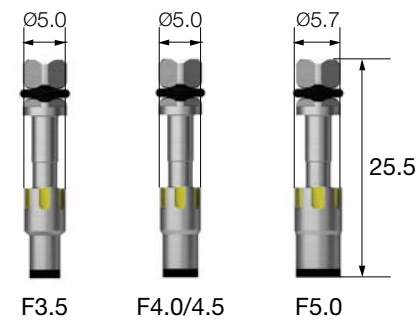

OSSTEM[®]
IMPLANT

Drilling Sequence OneGuide Drill

TSIII | SSIII | USIII

(Length : 10mm)

Ø3.5

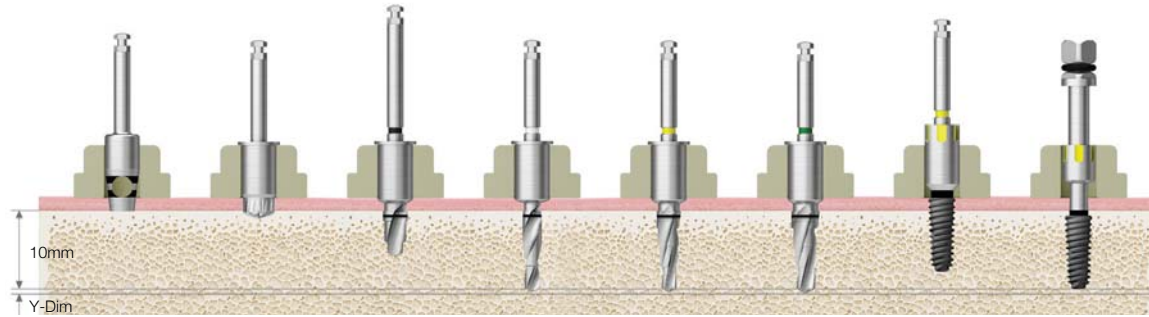

Bone Quality	Tissue Punch	Flattening Drill	Initial Drill	Ø 2.2 Drill	F3.5 Drill	F4.0 Drill	Nomount Driver	Fixture Driver
Soft	▶	(▶)	(F3.5 Soft) ▶	▶				
Normal	▶	(▶)	▶		▶		Implant Placement (Up to 80%)	Implant Placement
Hard	▶	(▶)	▶		▶	▶		

Ø5.0

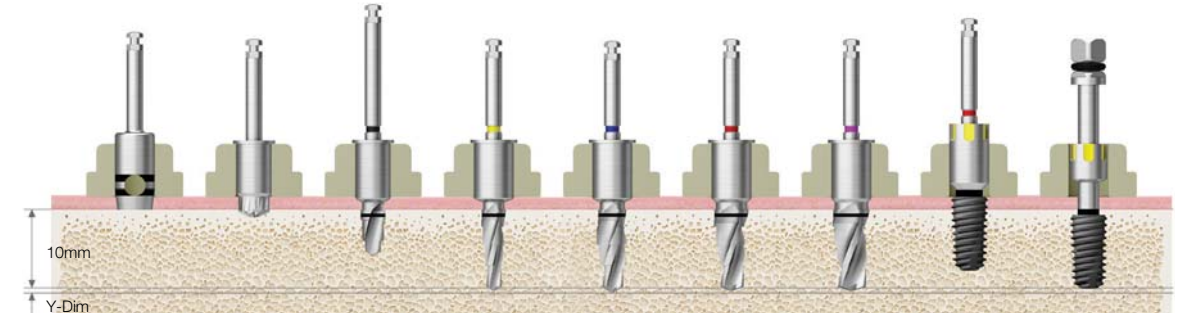

Bone Quality	Tissue Punch	Flattening Drill (W)	Initial Drill (W)	F3.5 Drill (W)	F4.5 Drill (W)	F5.0 Drill (W)	F5.5 Drill (W)	Implant Placement (Up to 80%)	Implant Placement
Soft	▶	(▶)	▶	▶	▶				
Normal	▶	(▶)	▶	▶		▶		Implant Placement (Up to 80%)	Implant Placement
Hard	▶	(▶)	▶	▶		▶	▶		

Ø4.0

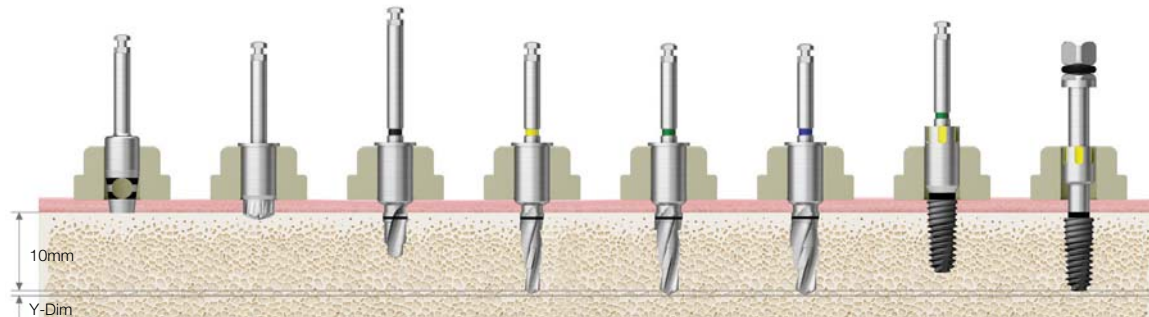

Bone Quality	Tissue Punch	Flattening Drill	Initial Drill	F3.5 Drill	F4.0 Drill	F4.5 Drill	Nomount Driver	Fixture Driver
Soft	▶	(▶)	▶	▶				
Normal	▶	(▶)	▶	▶	▶		Implant Placement (Up to 80%)	Implant Placement
Hard	▶	(▶)	▶	▶		▶		

Ø4.5

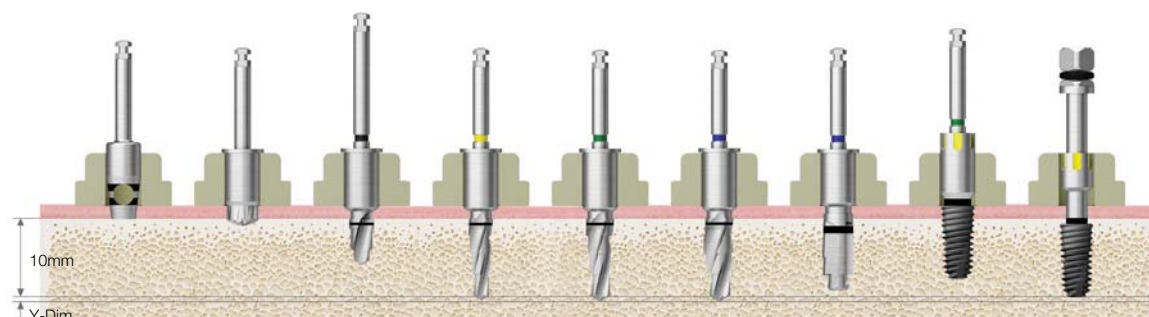

Bone Quality	Tissue Punch	Flattening Drill	Initial Drill	F3.5 Drill	F4.0 Drill	F4.5 Drill	F4.5 Cortical	Nomount Driver	Fixture Driver
Soft	▶	(▶)	▶	▶	▶				
Normal	▶	(▶)	▶	▶		▶		Implant Placement (Up to 80%)	Implant Placement
Hard	▶	(▶)	▶	▶		▶	▶		

Drilling Sequence OneGuide Drill

TSIII | SSIII | USIII

(Length : 10mm)

**G/H1.8
Ø3.5**

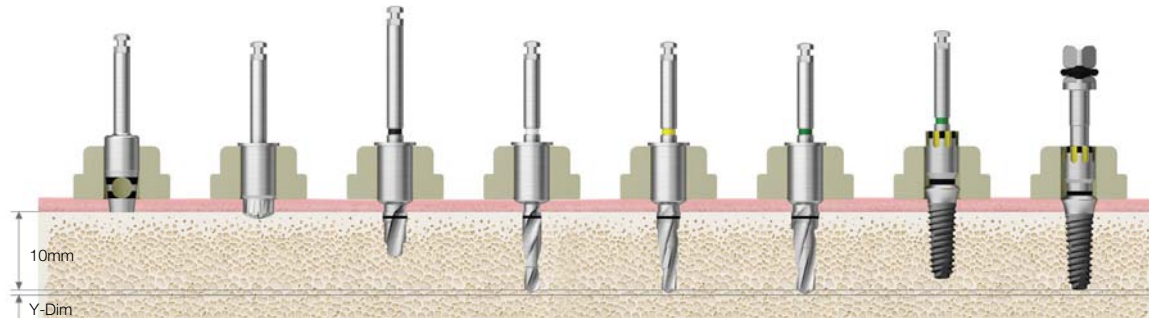

Bone Quality	Tissue Punch	Flattening Drill	Initial Drill	ø 2.2 Drill	F3.5 Drill	F4.0 Drill	Nomount Driver	Fixture Driver
Soft	▶	(▶)	(F3.5 Soft) ▶	▶				
Normal	▶	(▶)	▶		▶		Implant Placement (Up to 80%)	Implant Placement
Hard	▶	(▶)	▶		▶	▶		

**G/H2.8
Ø4.0**

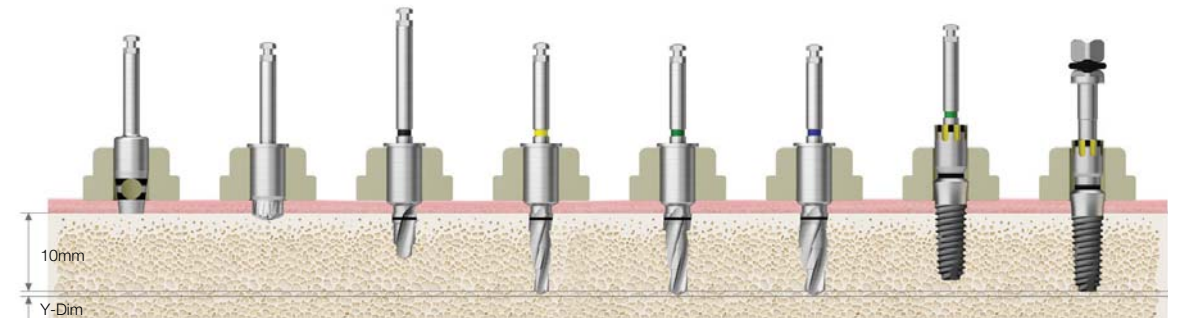

Bone Quality	Tissue Punch	Flattening Drill	Initial Drill	F3.5 Drill	F4.0 Drill	F4.5 Drill	Nomount Driver	Fixture Driver
Soft	▶	(▶)	▶	▶				
Normal	▶	(▶)	▶	▶	▶		Implant Placement (Up to 80%)	Implant Placement
Hard	▶	(▶)	▶	▶		▶		

**G/H2.8
Ø3.5**

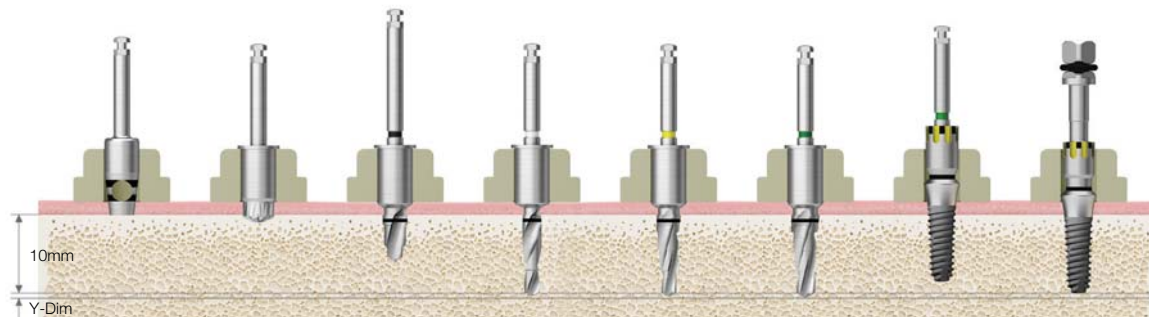

Bone Quality	Tissue Punch	Flattening Drill	Initial Drill	ø 2.2 Drill	F3.5 Drill	F4.0 Drill	Nomount Driver	Fixture Driver
Soft	▶	(▶)	(F3.5 Soft) ▶	▶				
Normal	▶	(▶)	▶		▶		Implant Placement (Up to 80%)	Implant Placement
Hard	▶	(▶)	▶		▶	▶		

**G/H1.8
Ø4.5**

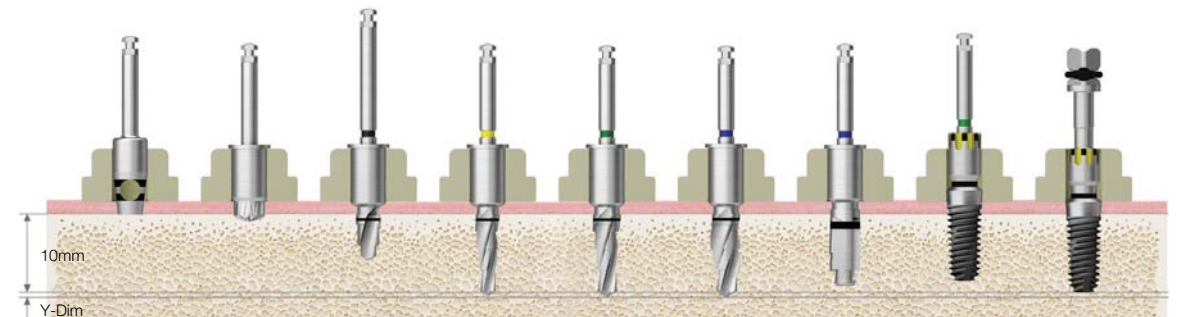

Bone Quality	Tissue Punch	Flattening Drill	Initial Drill	F3.5 Drill	F4.0 Drill	F4.5 Drill	F4.5 Cortical	Nomount Driver	Fixture Driver
Soft	▶	(▶)	▶	▶	▶				
Normal	▶	(▶)	▶	▶		▶		Implant Placement (Up to 80%)	Implant Placement
Hard	▶	(▶)	▶	▶		▶	▶		

**G/H1.8
Ø4.0**

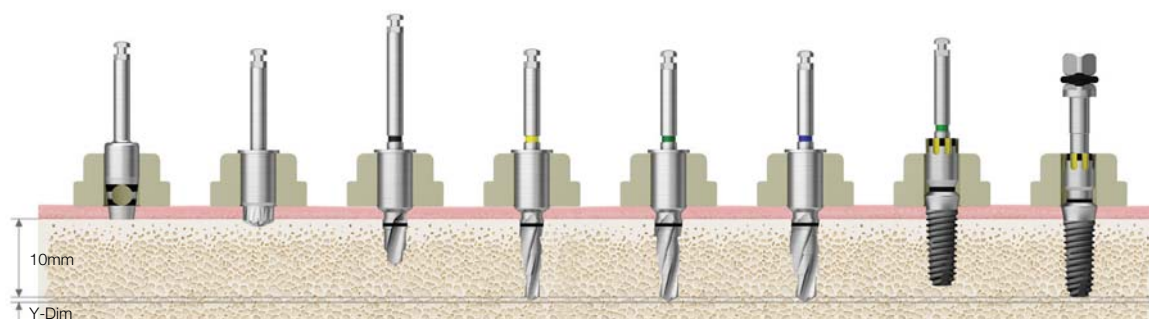

Bone Quality	Tissue Punch	Flattening Drill	Initial Drill	F3.5 Drill	F4.0 Drill	F4.5 Drill	Nomount Driver	Fixture Driver
Soft	▶	(▶)	▶	▶				
Normal	▶	(▶)	▶	▶	▶		Implant Placement (Up to 80%)	Implant Placement
Hard	▶	(▶)	▶	▶		▶		

**G/H2.8
Ø4.5**

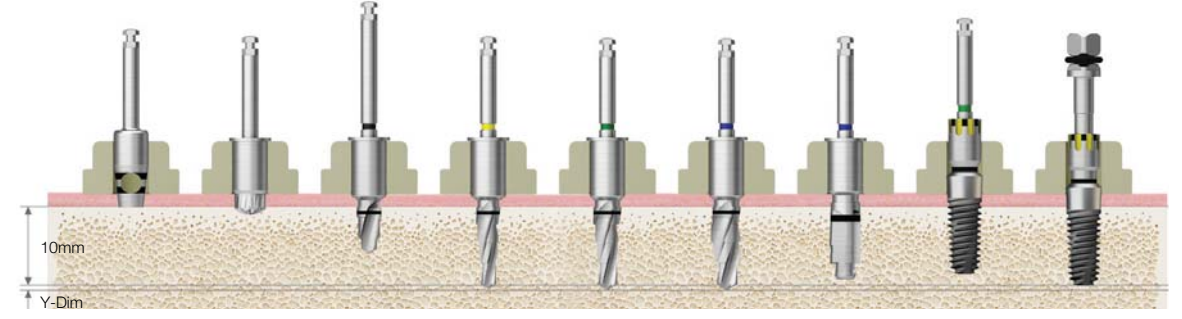

Bone Quality	Tissue Punch	Flattening Drill	Initial Drill	F3.5 Drill	F4.0 Drill	F4.5 Drill	F4.5 Cortical	Nomount Driver	Fixture Driver
Soft	▶	(▶)	▶	▶	▶				
Normal	▶	(▶)	▶	▶		▶		Implant Placement (Up to 80%)	Implant Placement
Hard	▶	(▶)	▶	▶		▶	▶		

030

OSSTEM KIT

031

OSSTEM KIT

Drilling Sequence OneGuide Drill

TSIII | SSIII | USIII

(Length : 10mm)

Ø3.5

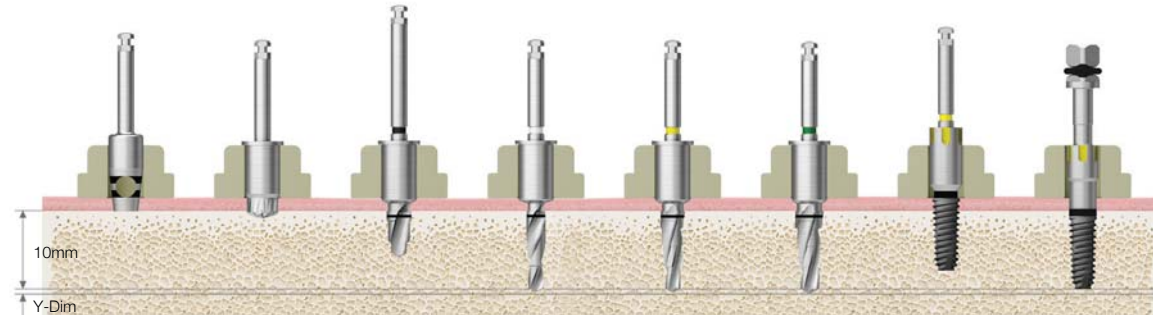

Bone Quality	Tissue Punch	Flattening Drill	Initial Drill	Ø 2.2 Drill	F3.5 Drill	F4.0 Drill	Nomount Driver	Fixture Driver
Soft	▶	(▶)	(F3.5 Soft) ▶	▶				
Normal	▶	(▶)	▶		▶		Implant Placement (Up to 80%)	Implant Placement
Hard	▶	(▶)	▶		▶	▶		

Ø5.0

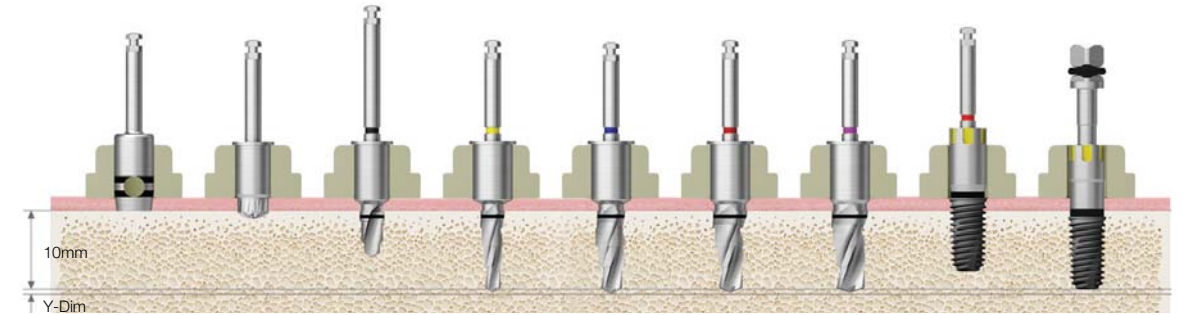

Bone Quality	Tissue Punch	Flattening Drill (W)	Initial Drill (W)	F3.5 Drill (W)	F4.5 Drill (W)	F5.0 Drill (W)	F5.5 Drill (W)	Implant Placement (Up to 80%)	Implant Placement
Soft	▶	(▶)	▶	▶	▶				
Normal	▶	(▶)	▶	▶		▶		Implant Placement (Up to 80%)	Implant Placement
Hard	▶	(▶)	▶	▶		▶	▶		

Ø4.0

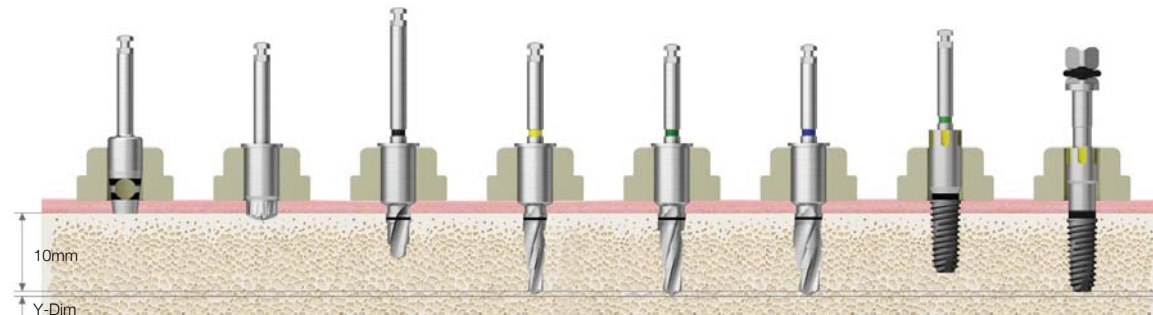

Bone Quality	Tissue Punch	Flattening Drill	Initial Drill	F3.5 Drill	F4.0 Drill	F4.5 Drill	Nomount Driver	Fixture Driver
Soft	▶	(▶)	▶	▶				
Normal	▶	(▶)	▶	▶	▶		Implant Placement (Up to 80%)	Implant Placement
Hard	▶	(▶)	▶	▶		▶		

Ø4.5

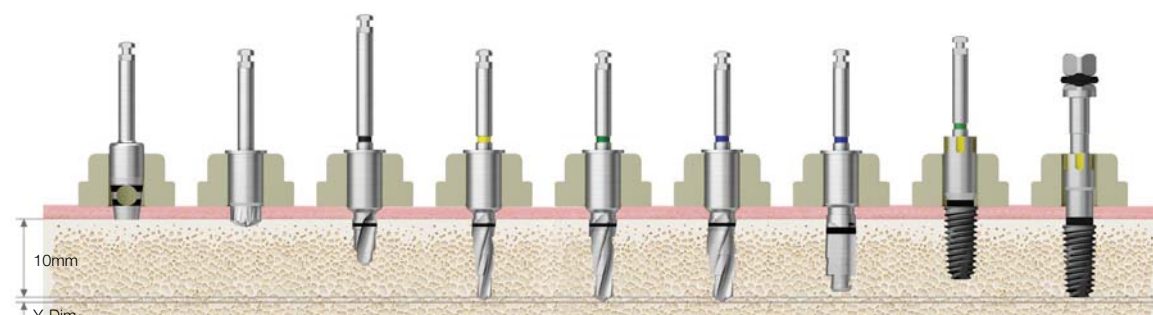

Bone Quality	Tissue Punch	Flattening Drill	Initial Drill	F3.5 Drill	F4.0 Drill	F4.5 Drill	F4.5 Cortical	Nomount Driver	Fixture Driver
Soft	▶	(▶)	▶	▶	▶				
Normal	▶	(▶)	▶	▶		▶		Implant Placement (Up to 80%)	Implant Placement
Hard	▶	(▶)	▶	▶		▶	▶		

Drilling Sequence OneGuide Drill

TSIV

(Length : 10mm)

Ø4.0

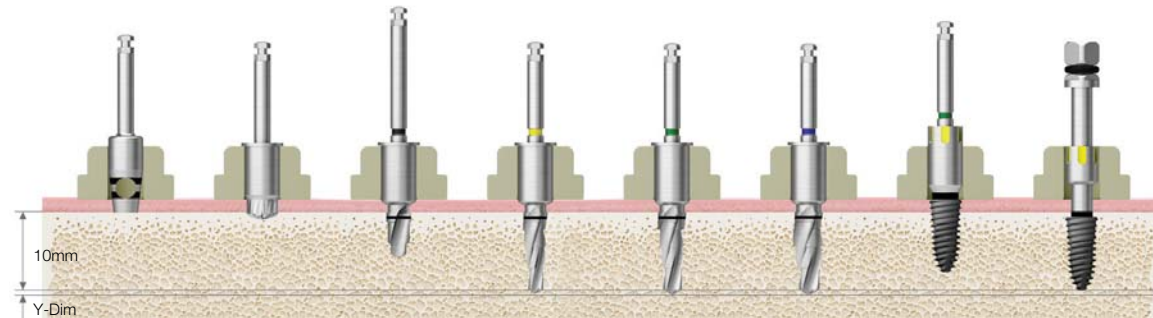

Bone Quality	Tissue Punch	Flattening Drill	Initial Drill	F3.5 Drill	F4.0 Drill	F4.5 Drill	Nomount Driver	Fixture Driver
Soft	▶	(▶)	▶	▶			Implant Placement (Up to 80%)	Implant Placement
Normal	▶	(▶)	▶	▶	▶			
Hard								

Ø4.5

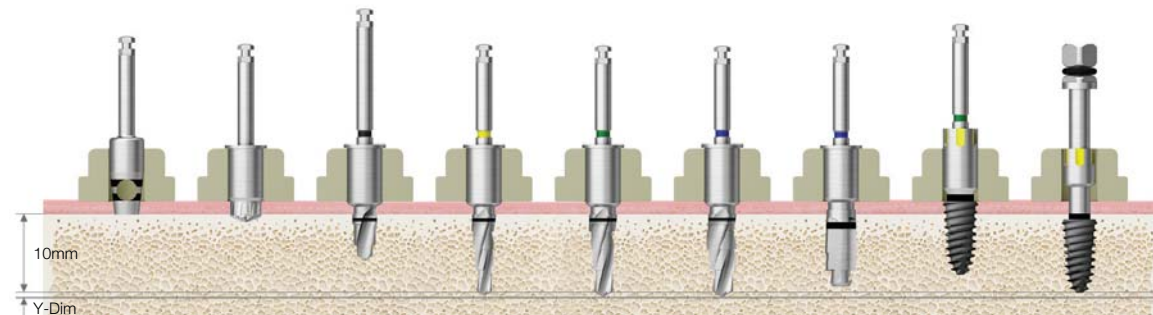

Bone Quality	Tissue Punch	Flattening Drill	Initial Drill	F3.5 Drill	F4.0 Drill	F4.5 Drill	F4.5 Cortical	Nomount Driver	Fixture Driver
Soft	▶	(▶)	▶	▶	▶			Implant Placement (Up to 80%)	Implant Placement
Normal	▶	(▶)	▶	▶		▶			
Hard									

Ø5.0

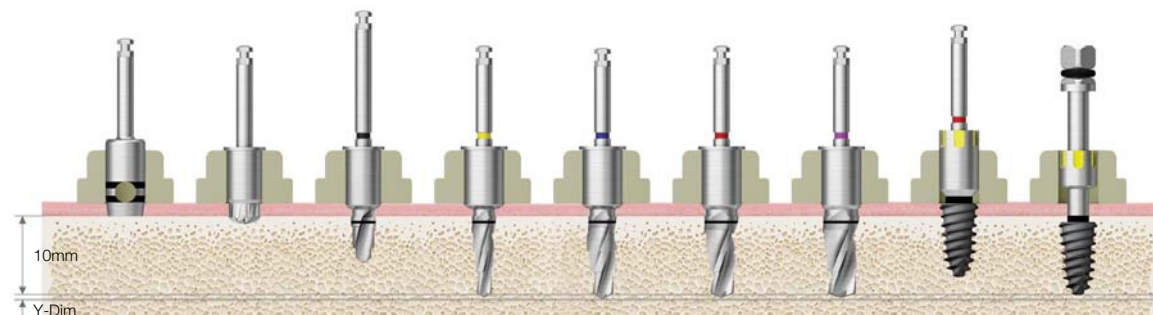

Bone Quality	Tissue Punch	Flattening Drill (W)	Initial Drill (W)	F3.5 Drill (W)	F4.5 Drill (W)	F5.0 Drill (W)	F5.5 Drill (W)	Nomount Driver	Fixture Driver
Soft	▶	(▶)	▶	▶	▶			Implant Placement (Up to 80%)	Implant Placement
Normal	▶	(▶)	▶	▶		▶			
Hard									

OSSTEM[®]
IMPLANT

OneCAS KIT (OOCK)

OneCAS KIT Surgical Instruments

For **TSII / III** **SSII / III** **USII / III**

Top panel components

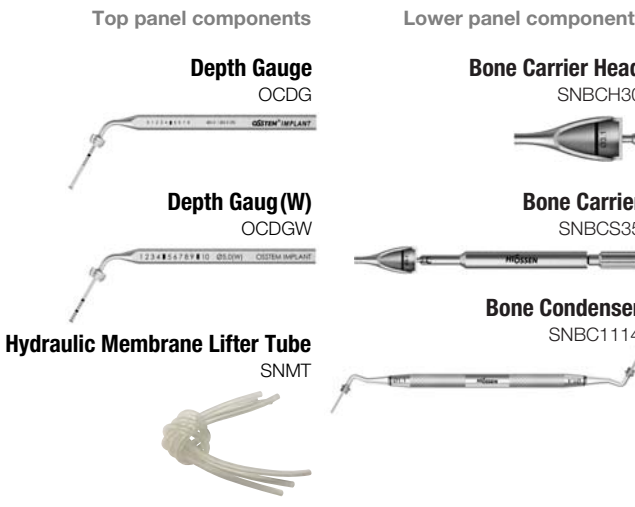

Lower panel components

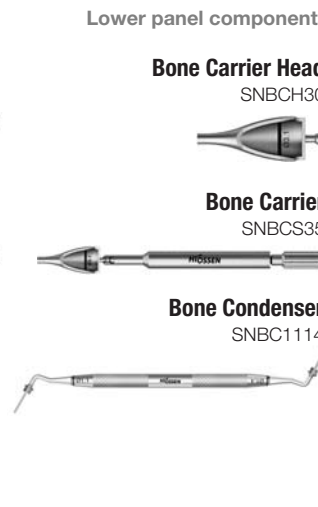

Flattening Drill (OGFD45)

Stopper (OCDS01, OCDS04, OCDS07) - Yellow

Stopper (OCDS02, OCDS05, OCDS08) - Purple

Stopper (OCDS03, OCDS06, OCDS09) - Blue

Stopper (W) (OCDS02W, OCDS05W, OCDS08W) - Purple

Stopper (W) (OCDS01W, OCDS04W, OCDS07W) - Yellow

Stopper (W) (OCDS03W, OCDS06W, OCDS09W) - Blue

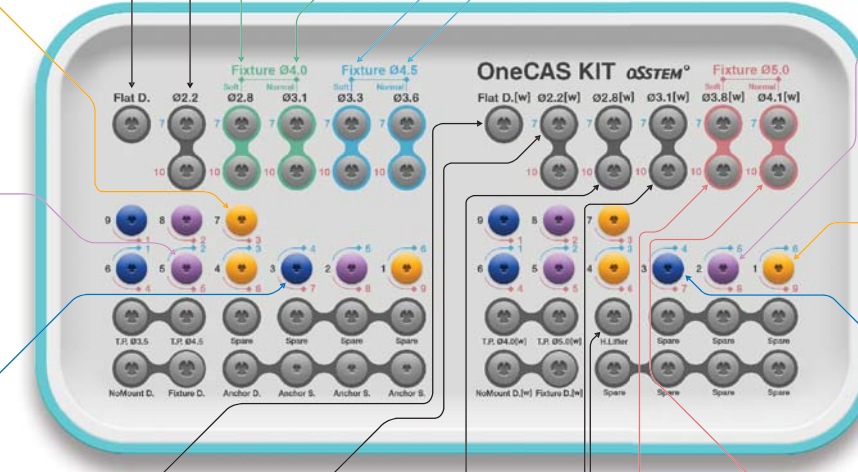

OneCAS KIT αSTEM

Flattening Drill (W) (OGFD52W)

Stopper (OCDS03, OCDS06, OCDS09) - Blue

Stopper (W) (OCDS03W, OCDS06W, OCDS09W) - Blue

OneCAS Ø2.2 Twist Drill

- 1mm under drilling is recommended to the lower margin of maxillary sinus
- Use a stopper for safety lift
- 1mm shorter than normal twist drill

For F4.0/4.5

L	TL	Ø2.2
	Y-Dim	
7	33.2	OCD2207
10	36.2	OCD2210

For F5.0 (W)

L	TL	Ø2.2
	Y-Dim	
7	33.2	OCD2207W
10	36.2	OCD2210W

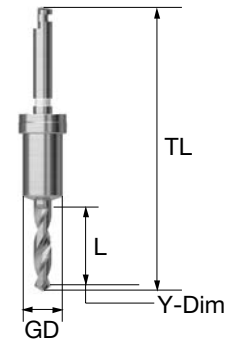

OneCAS Drill

- Use with guide of OneGuide system
- The membrane is safely raised during maxillary sinus surgery
- Possible to collect autogenous bone at low rpm speed
- Use a stopper for safety lift
- Final drill diameter selection based on bone quality
- Recommended rpm speed : 400-800rpm

For F4.0/4.5

L	TL	Ø2.8	Ø3.1	Ø3.3	Ø3.6
	GD				
7	33.6	OCD2807	OCD3107	OCD3307	OCD3607
10	36.6	OCD2810	OCD3110	OCD3310	OCD3610

For F5.0 (W)

L	TL	Ø2.8	Ø3.1	Ø3.8	Ø4.1
	GD				
7	33.6	OCD2807W	OCD3107W	OCD3807W	OCD4107W
10	36.6	OCD2810W	OCD3110W	OCD3810W	OCD4110W

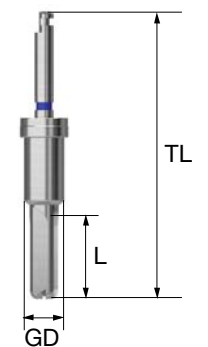

OneCAS KIT Surgical Instruments

OneCAS Stopper

- Stopper number is the length to stop when drill or instrument is tightened
- When the 7mm drill is tightened on the KIT middle plate, the protruding length is indicated in blue and when 10mm drill is tightened, the protruding length is indicated in red
- Color coding by length
- Recommended number of use : 50times

For F4.0/4.5

L	1	2	3	4	5	6	7	8	9
									
	OCDS01	OCDS02	OCDS03	OCDS04	OCDS05	OCDS06	OCDS07	OCDS08	OCDS09
Color	Yellow	Purple	Blue	Yellow	Purple	Blue	Yellow	Purple	Blue

For F5.0 (W)

L	1	2	3	4	5	6	7	8	9
									
	OCDS01W	OCDS02W	OCDS03W	OCDS04W	OCDS05W	OCDS06W	OCDS07W	OCDS08W	OCDS09W
Color	Yellow	Purple	Blue	Yellow	Purple	Blue	Yellow	Purple	Blue

Depth Gauge

- Check if maxillary sinus is lifted
- Measure residual bone depth
- Use a stopper for safety lift
- Same depth marking line with 10mm drill



For F4.0/4.5

L \ GD	5.0
10.6	OCDG

For F5.0 (W)

L \ GD	5.7
10.6	OCDGW

Parallel Guide KIT (OPGPK)



Parallel Guide Full KIT (OPGAK)



Lower panel components



Denture Guide PGODA

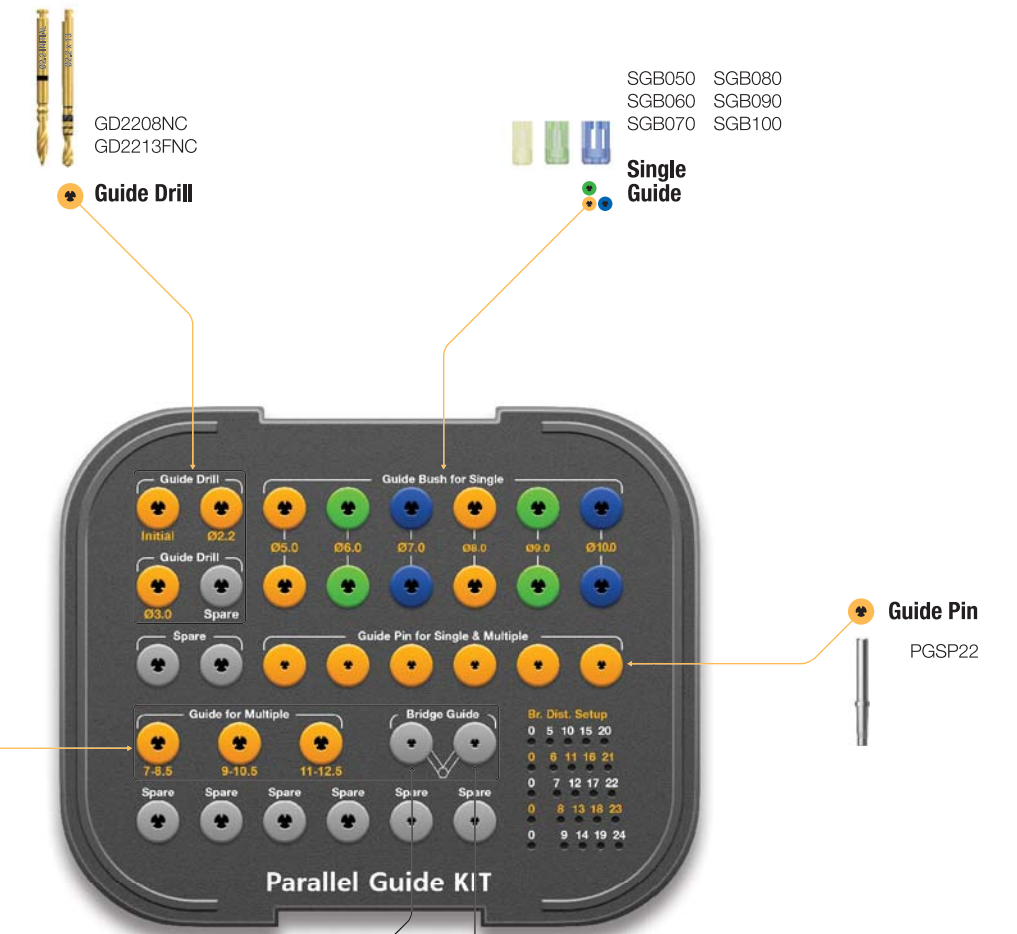
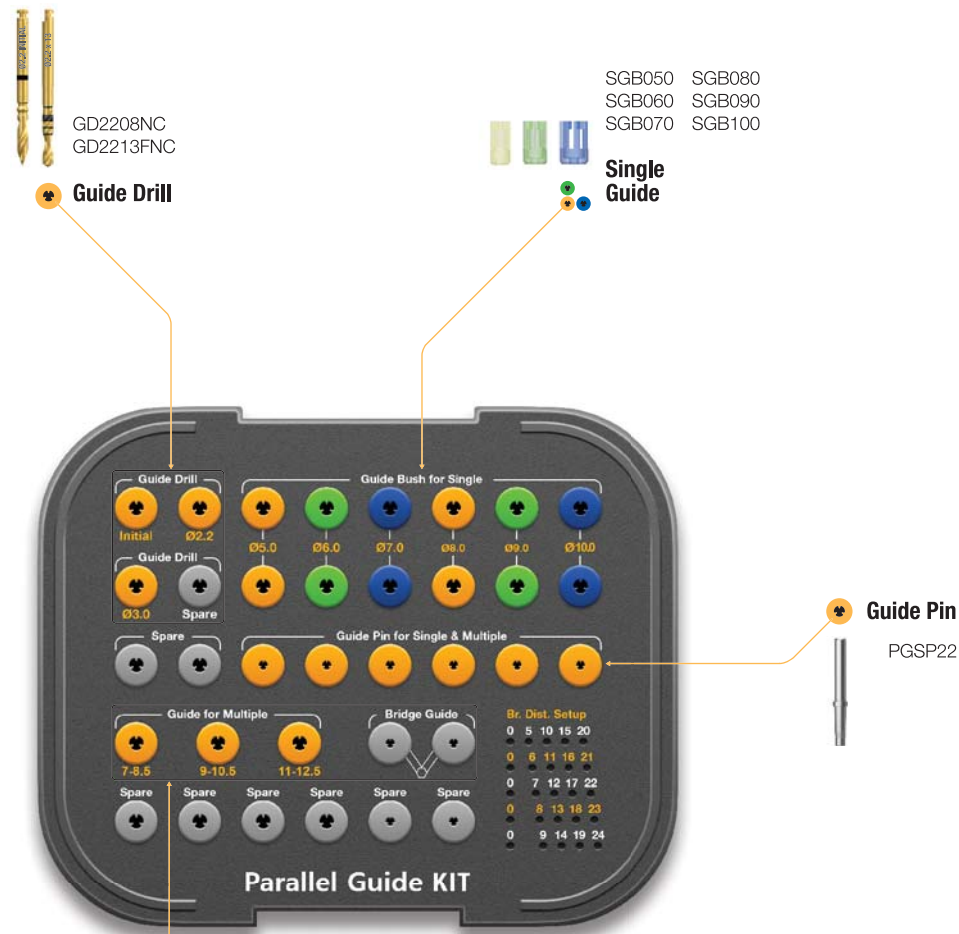

Parallel Guide KIT Surgical Instruments

Guide Drill

- Initial drill : drilling depth can be adjusted by fastening it to the single guide
- \varnothing 2.2 twist drill : used with the bridge guide
- \varnothing 3.0 twist drill : final drill

D	\varnothing 2.2	\varnothing 3.0
Initial drill	GD2208NC	-
Twist drill	GD2213FNC	2D3011LC01

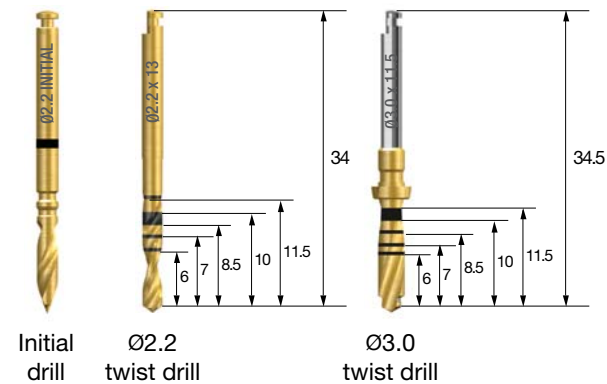

Single Guide

- Transparent material indicates the location and direction of drilling
- Available in six sizes from \varnothing 5.0~10.0, must take into account the mesiodistal crown diameters
- Packing unit : 2ea
- ※ Disposable; do not re-use
- ※ Drilling depth can be adjusted from 6~8mm, refer to the initial drill marker and top of the single guide marker

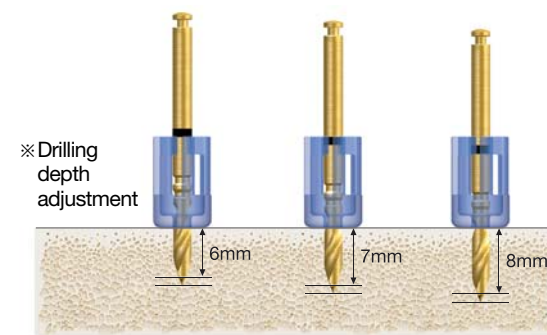

F5.0	F6.0	F7.0	F8.0	F9.0	F10.0
					
SGB050	SGB060	SGB070	SGB080	SGB090	SGB100

Guide Pin

- Checks drilling path and secures the single guide



PGSP22

Bridge Guide

- Adjustable drill guide for setting up the optimal implant placement and initial drilling sites
- Fan type : range between 7~12.5mm, 0.5mm increments
- Compass type : range between 5~24mm, 1mm increments
- Set distance using the kit's middle plate



Type \ Distance	7~8.5	9~10.5	11~12.5	5~24
Fan	PGBRA070	PGBRA090	PGBRA110	-
Compass	-	-	-	PGBPA

Multi Joint Handle ^{Option}

- Handle connects to the ball head of the bridge guide, provides information about the guide from outside the mouth



MJH

Denture Guide ^{Option}

- Angle adjustable denture guide for fully edentulous cases
- Using a stone model, arrange the guide to the ideal configuration. Tighten and set the guide using the L-wrench. Transfer to the patient to start surgery.
- Markers represent tooth positions, 2, 3, 4, 5, etc... starting from the midline



PGODA

Parallel Guide KIT Surgical Instruments

L-wrench Option

- Tightens the denture guide after size adjustments



Distance Setup Pin Option

- Compass type bridge guide and pin type denture guide



SmartGuide KIT (OSGK)



Lower panel components

Guide Pin (4ea)
SGP 22



Round bur (2ea)
RAHM1018



Ø2.2 Cast Drill (2ea) For stone models
2D2208LC01

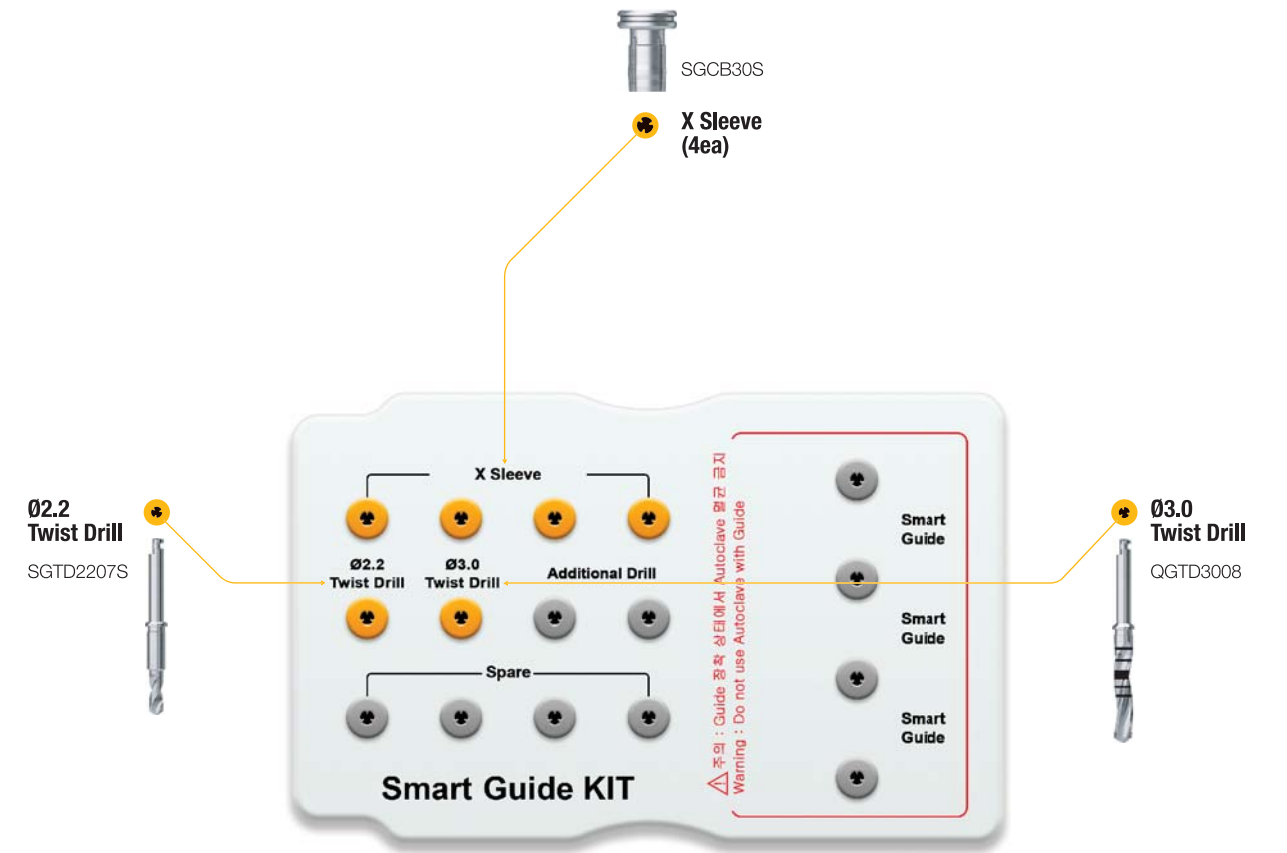

SmartGuide KIT Surgical Instruments

SmartGuide

- Medical grade thermoplastic material
- Becomes flexible when immersed in 70°C water for approx. 1min
- Template hardens in 1min at room temperature

※ Disposable; do not re-use; sterilizable under low temperature (Do not autoclave, do not use hydrogen peroxide)

Type	Single	Free-end Bridge	2-Unit Br.: small	2-Unit Br.: large
				
	SGTSS	SGTFB90LS	SGTB63SS	SGTB85LS

Twist Drill

- Drills specifically for SmartGuide
- Stable drilling through the SmartGuide sleeve
- Initial drilling using the $\varnothing 2.2$, followed by $\varnothing 3.0$ drill
- Recommended speed : 1,200~1,500rpm

D	$\varnothing 2.2$	$\varnothing 3.0$
	SGTD2207S	QGTD3008



X Sleeve

- Connect to the SmartGuide sleeve and insert into the surgical site
- After tightening to a SmartGuide outside the mouth, tighten it in the mouth

	SGCB30S
--	---------



Round Bur

- Marks site of the guide pin on a stone model
- Number of usages : 10 times
- Recommended speed : 1,200~1,500rpm

D	$\varnothing 1.8$
	RAHM1018



$\varnothing 2.2$ Twist Drill For stone models

- Drills the hole in the stone model for the guide pin
- Number of usages : 10 times
- Drill after marketing the site with the round bur
- Recommended speed : 1,200~1,500rpm

D	$\varnothing 2.2$
	2D2208LC01



Guide Pin

- Pin that secures the SmartGuide to the stone model
- Connected to the SmartGuide sleeve

	SGP22
--	-------



122 Taper KIT (O122TPK)



Top panel components

For **TSIII / IV** **SSIII** **USIII / IV**

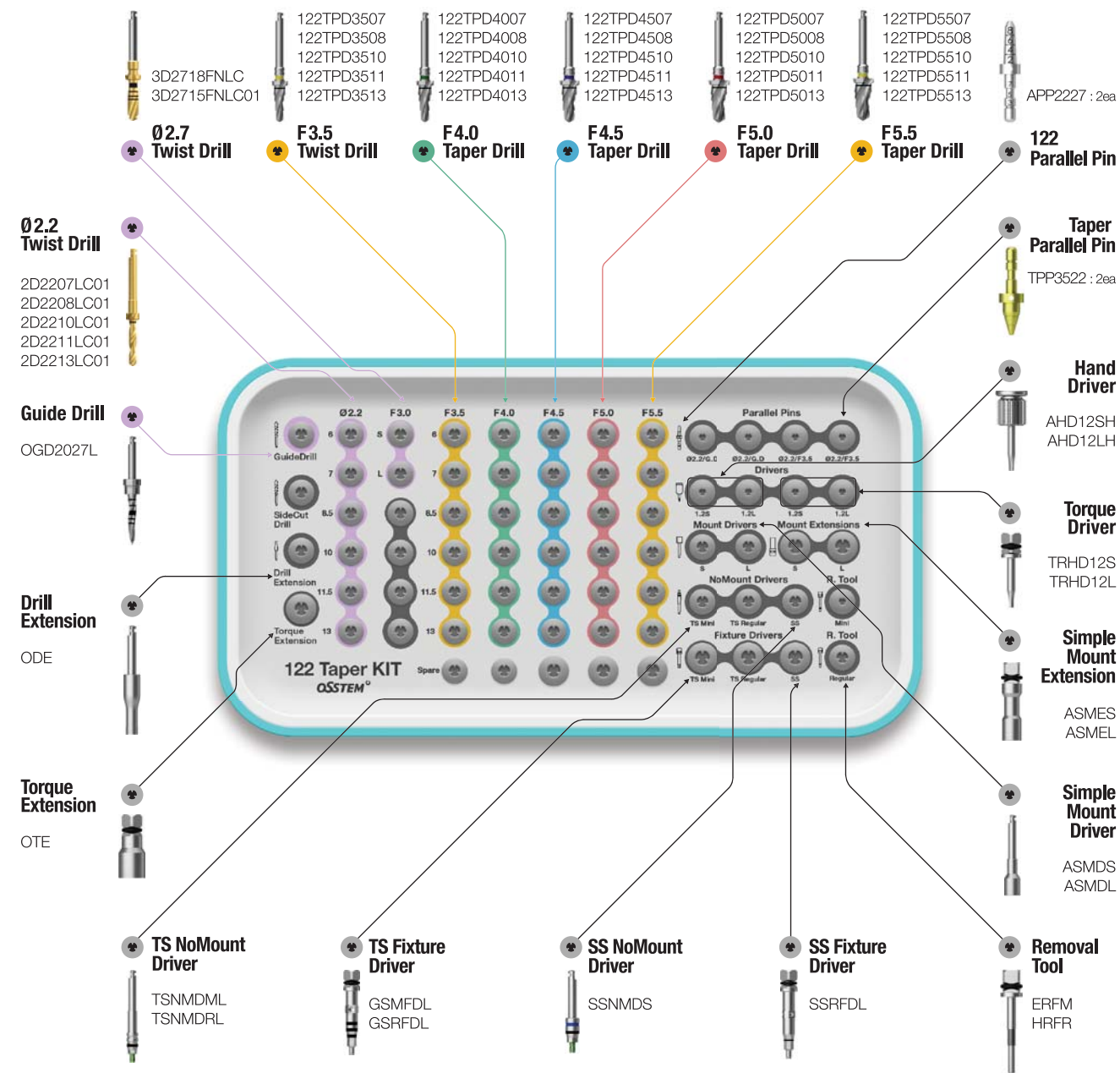
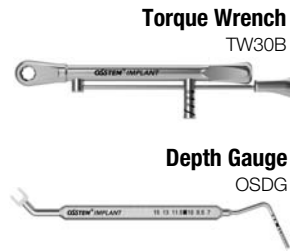

122 Taper Full KIT (O122TPFK)

Top panel components

For **TSIII / IV** **SSIII** **USIII / IV** **III / IV Ultra-wide**

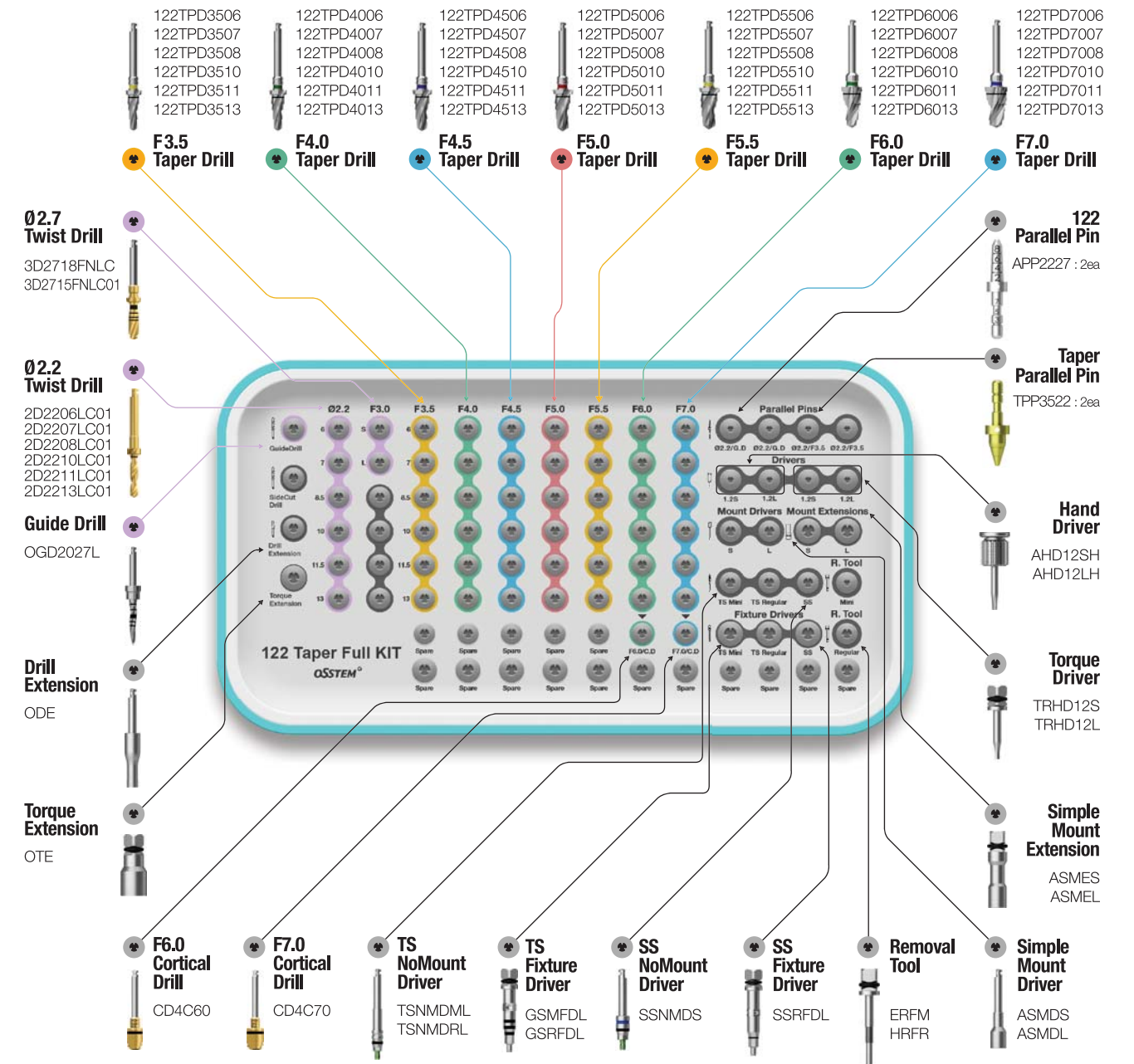
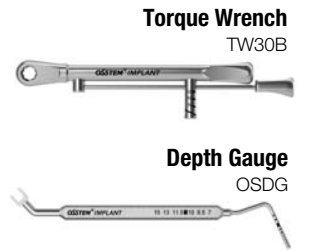

122 Taper KIT Surgical Instruments

122 Taper Drill

- Taper drill for taper (III type) fixture
- Specification by diameter and length
- Color coding displays fixture diameter
- One step large-diameter drill is used to remove cortical bone from the hard bone
- 122 taper KIT single item (excluded from taper KIT)
- F = Fixture

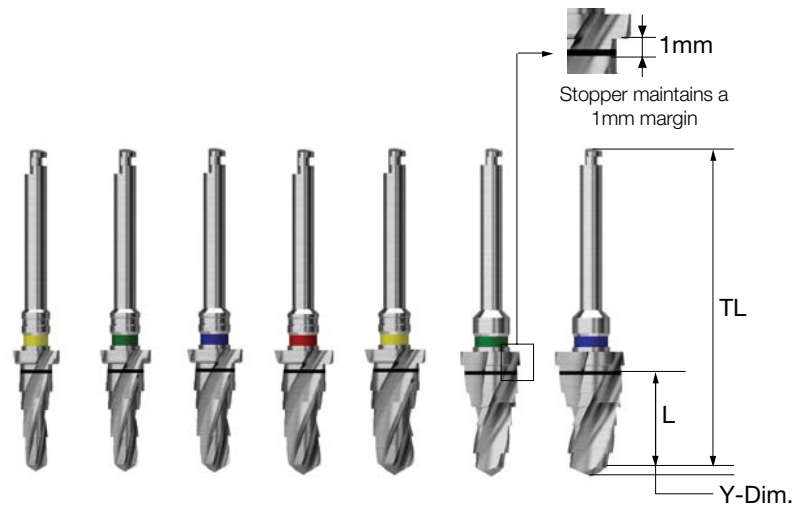

L	TL	F3.5	F4.0	F4.5	F5.0	F5.5	F6.0	F7.0
	Y-Dim.	0.7	0.9	1.0	1.0	1.0	1.0	1.0
4.0	29.5	122TPD3504	122TPD4004	122TPD4504	122TPD5004	122TPD5504	-	-
5.0	29.5	122TPD3505	122TPD4005	122TPD4505	122TPD5005	122TPD5505	-	-
6.0	30.5	122TPD3506	122TPD4006	122TPD4506	122TPD5006	122TPD5506	122TPD6006	122TPD7006
7.0	31.5	122TPD3507	122TPD4007	122TPD4507	122TPD5007	122TPD5507	122TPD6007	122TPD7007
8.5	33	122TPD3508	122TPD4008	122TPD4508	122TPD5008	122TPD5508	122TPD6008	122TPD7008
10	34.5	122TPD3510	122TPD4010	122TPD4510	122TPD5010	122TPD5510	122TPD6010	122TPD7010
11.5	34.5	122TPD3511	122TPD4011	122TPD4511	122TPD5011	122TPD5511	122TPD6011	122TPD7011
13	36	122TPD3513	122TPD4013	122TPD4513	122TPD5013	122TPD5513	122TPD6013	122TPD7013
15	38	122TPD3515	122TPD4015	122TPD4515	122TPD5015	122TPD5515	-	-
Color		Yellow	Green	Blue	Red	Yellow	Green	Blue

Parallel Pin for 122 Taper Drill

- Parallel pin for 122 taper drill
- Used for checking position and direction of bone preparation
- Lower part for 2.2 drill, upper part for guide drill
- 122 taper KIT single item (excluded from taper KIT)
- Other components same as taper KIT

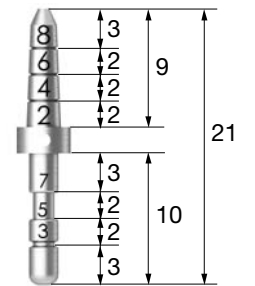

APP2227

※ Refer to surgical instruments for other components (106p-)

Cortical Drill for Ultra-Wide

- Drill used to remove cortical bone from hard bone (for ultra-wide)
- Dedicated drill by fixture diameter
- It is recommended to drill to the bottom line of the marking line
- F = Fixture

F6.0	F7.0
CD4C60	CD4C70

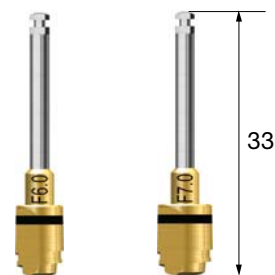

Drilling Sequence 122 Taper Drill

TSIII | SSIII | USIII

(Length : 10mm)

Ø3.0mm

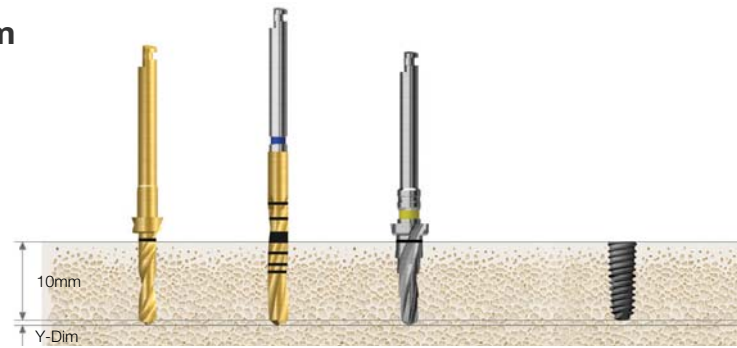

Bone Quality	Ø 2.2 Drill	Ø 2.7 Drill	F3.5 Taper Drill	Ø 3.0 Fixture
Soft	▶			Implant Placement
Normal	▶	▶		
Hard	▶		▶	

Ø3.5mm

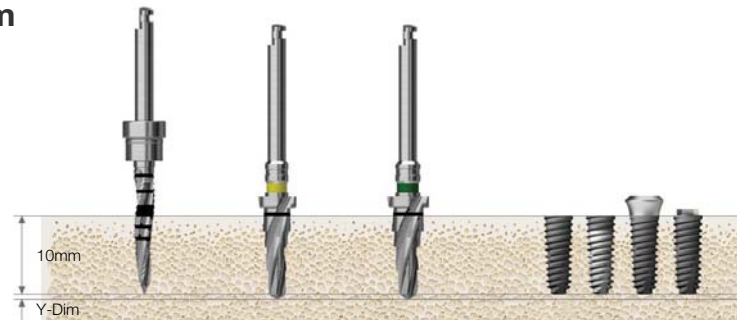

Bone Quality	Guide Drill	F3.5 Taper Drill	F4.0 Taper Drill	Ø 3.5 Fixture
Soft	▶			Implant Placement
Normal	▶	▶		
Hard	▶	▶	▶	

Ø4.0mm

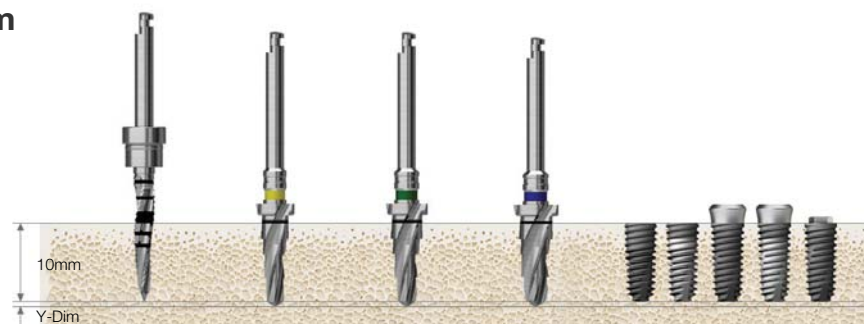

Bone Quality	Guide Drill	F3.5 Taper Drill	F4.0 Taper Drill	F4.5 Taper Drill	Ø 4.0 Fixture
Soft	▶	▶			Implant Placement
Normal	▶	▶	▶		
Hard	▶	▶		▶	

F5.5 taper cortical drill marking line Bottom line 6mm or less, middle line 7mm, top line 8.5mm or more fixture placement standard

Recommended placement torque Below than 40Ncm, TSIII/SSIII HA : below than 35Ncm (In hard bone, HA coating layer cracking and peeling can occur)

TS fixture placement depth The normal bone is placed 1mm deeper than the bone level, and the soft bone is placed at the bone level to maintain the fixed strength

Ø4.5mm

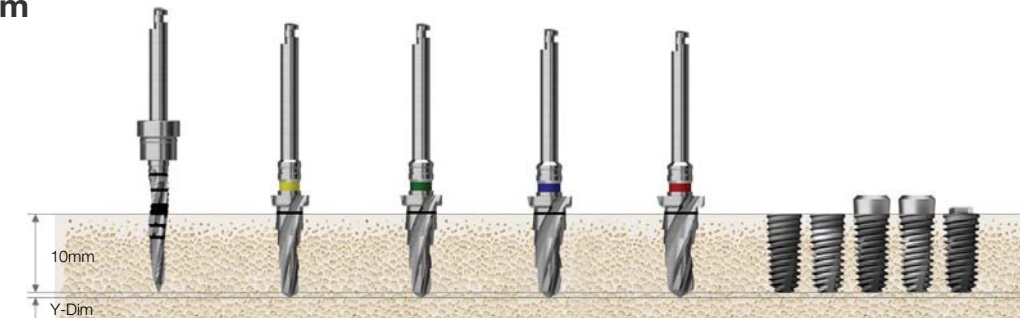

Bone Quality	Guide Drill	F3.5 Taper Drill	F4.0 Taper Drill	F4.5 Taper Drill	F5.0 Taper Drill	Ø 4.5 Fixture
Soft	▶			▶		Implant Placement
Normal	▶	▶		▶		
Hard	▶	▶			▶	

Ø5.0mm

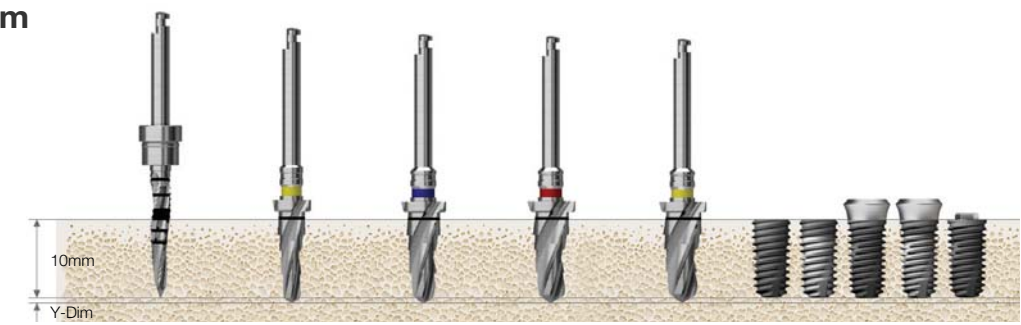

Bone Quality	Guide Drill	F3.5 Taper Drill	F4.5 Taper Drill	F5.0 Taper Drill	F5.5 Taper Drill	Ø 5.0 Fixture
Soft	▶			▶		Implant Placement
Normal	▶	▶		▶		
Hard	▶	▶			▶	

Ø5.5mm

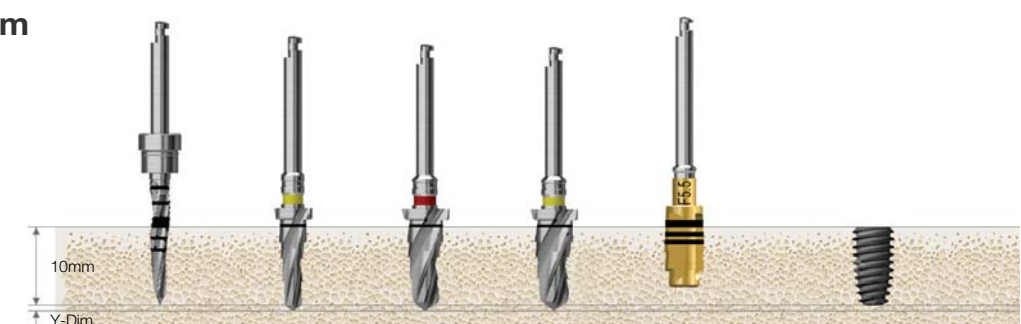

Bone Quality	Guide Drill	F3.5 Taper Drill	F5.0 Taper Drill	F5.5 Taper Drill	F5.5 Taper Cortical Drill	Ø 5.5 Fixture
Soft	▶			▶		Implant Placement
Normal	▶	▶		▶		
Hard	▶	▶			▶	

Drilling Sequence 122 Taper Drill

TSIII Ultra-wide | SSIII Ultra-wide | USIII Ultra-wide

(Length : 10mm)

Ø6.0mm

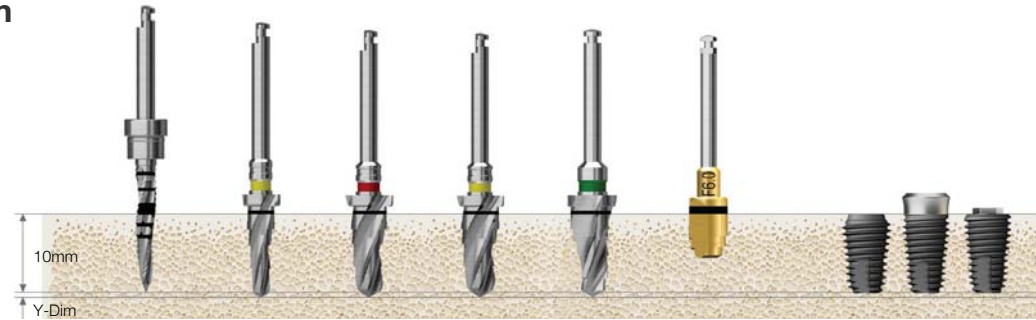

Bone Quality	Guide Drill	F3.5 Taper Drill	F5.0 Taper Drill	F5.5 Taper Drill	F6.0 Taper Drill	F6.0 Cortical Drill	Ø 6.0 Fixture
Soft	▶		▶	▶			Implant Placement
Normal	▶	▶	▶		▶		
Hard	▶	▶	▶		▶	▶	

Ø7.0mm

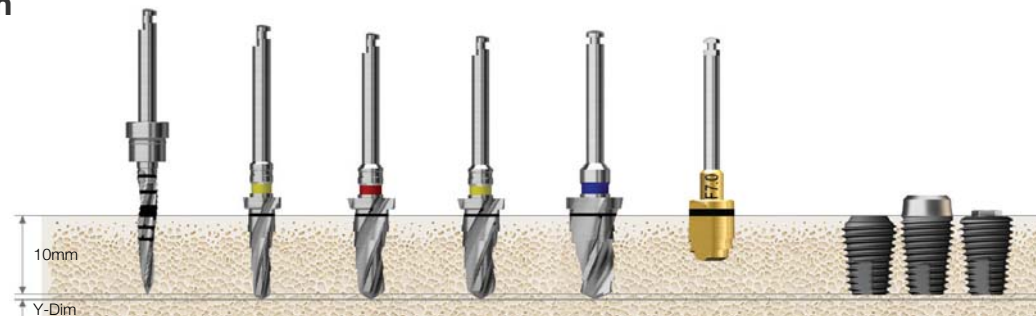

Bone Quality	Guide Drill	F3.5 Taper Drill	F5.0 Taper Drill	F6.0 Taper Drill	F7.0 Taper Drill	F7.0 Cortical Drill	Ø 7.0 Fixture
Soft	▶		▶	▶			Implant Placement
Normal	▶	▶	▶		▶		
Hard	▶	▶	▶		▶	▶	

Drilling Sequence 122 Taper Drill

TSIV | USIV

(Length : 10mm)

Ø4.0mm

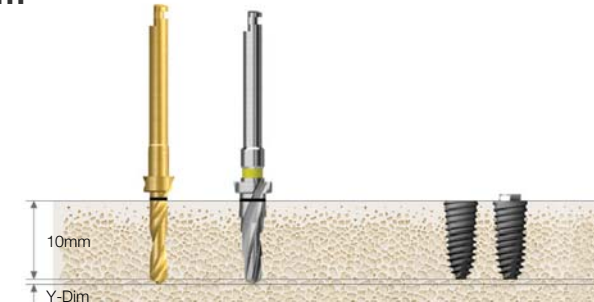

Bone Quality	Ø 2.2 Drill	F3.5 Taper Drill	Ø 4.0 Fixture
D4	▶		Implant Placement
Soft	▶	▶	

Ø4.5mm

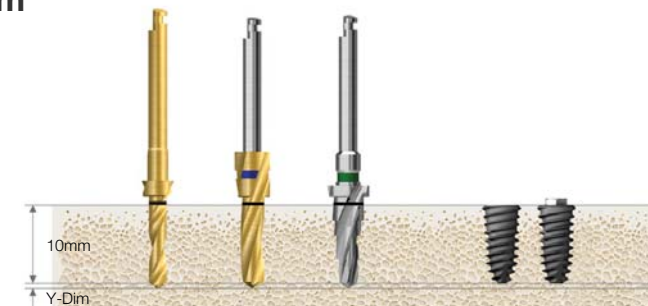

Bone Quality	Ø 2.2 Drill	Ø 3.0 Drill	F4.0 Taper Drill	Ø 4.5 Fixture
D4		▶		Implant Placement
Soft	▶		▶	

Ø5.0mm

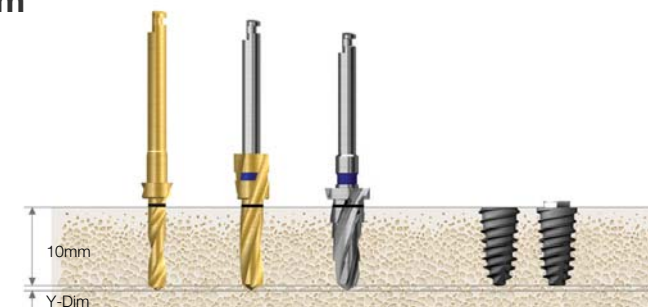

Bone Quality	Ø 2.2 Drill	Ø 3.0 Drill	F4.5 Taper Drill	Ø 5.0 Fixture
D4		▶		Implant Placement
Soft	▶		▶	

F5,5 taper cortical drill marking line Bottom line 6mm or less, middle line 7mm, top line 8,5mm or more fixture placement standard

Recommended placement torque Below than 40Ncm, TSIII/SSIII HA : below than 35Ncm (In hard bone, HA coating layer cracking and peeling can occur)

TS fixture placement depth The normal bone is placed 1mm deeper than the bone level, and the soft bone is placed at the bone level to maintain the fixed strength

Drilling Sequence 122 Taper Drill

TSIV Ultra-wide

(Length : 10mm)

Ø6.0mm

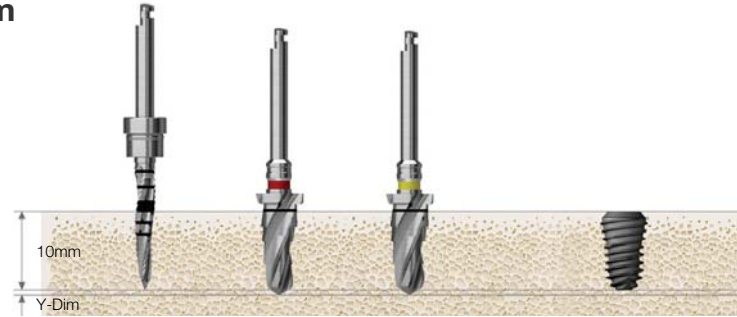

Bone Quality	Guide Drill	F5.0 Taper Drill	F5.5 Taper Drill	Ø 6.0 Fixture
D4	▶	▶		Implant Placement
Soft	▶	▶	▶	

Ø7.0mm

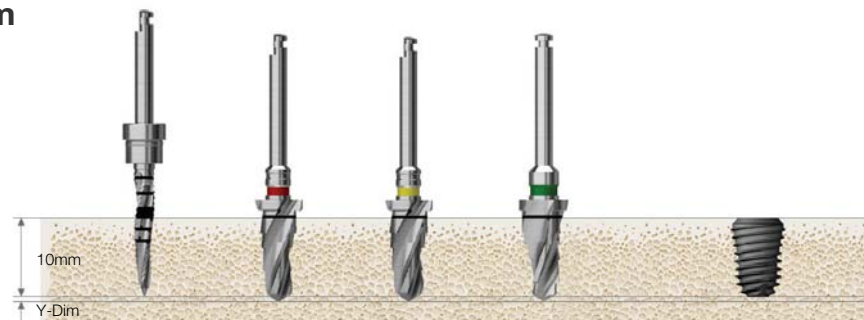

Bone Quality	Guide Drill	F5.0 Taper Drill	F5.5 Taper Drill	F6.0 Taper Drill	Ø 7.0 Fixture
D4	▶	▶	▶		Implant Placement
Soft	▶	▶	▶	▶	



F5,5 taper cortical drill marking line Bottom line 6mm or less, middle line 7mm, top line 8,5mm or more fixture placement standard
 Recommended placement torque Below than 40Ncm, TSIII/SSIII HA : below than 35Ncm (In hard bone, HA coating layer cracking and peeling can occur)
 TS fixture placement depth The normal bone is placed 1mm deeper than the bone level, and the soft bone is placed at the bone level to maintain the fixed strength

Taper KIT (OTSK)

For **TSIII / IV** **SSIII** **USIII**

Top panel components

Torque Wrench
TW30B



Depth Gauge
OSDG

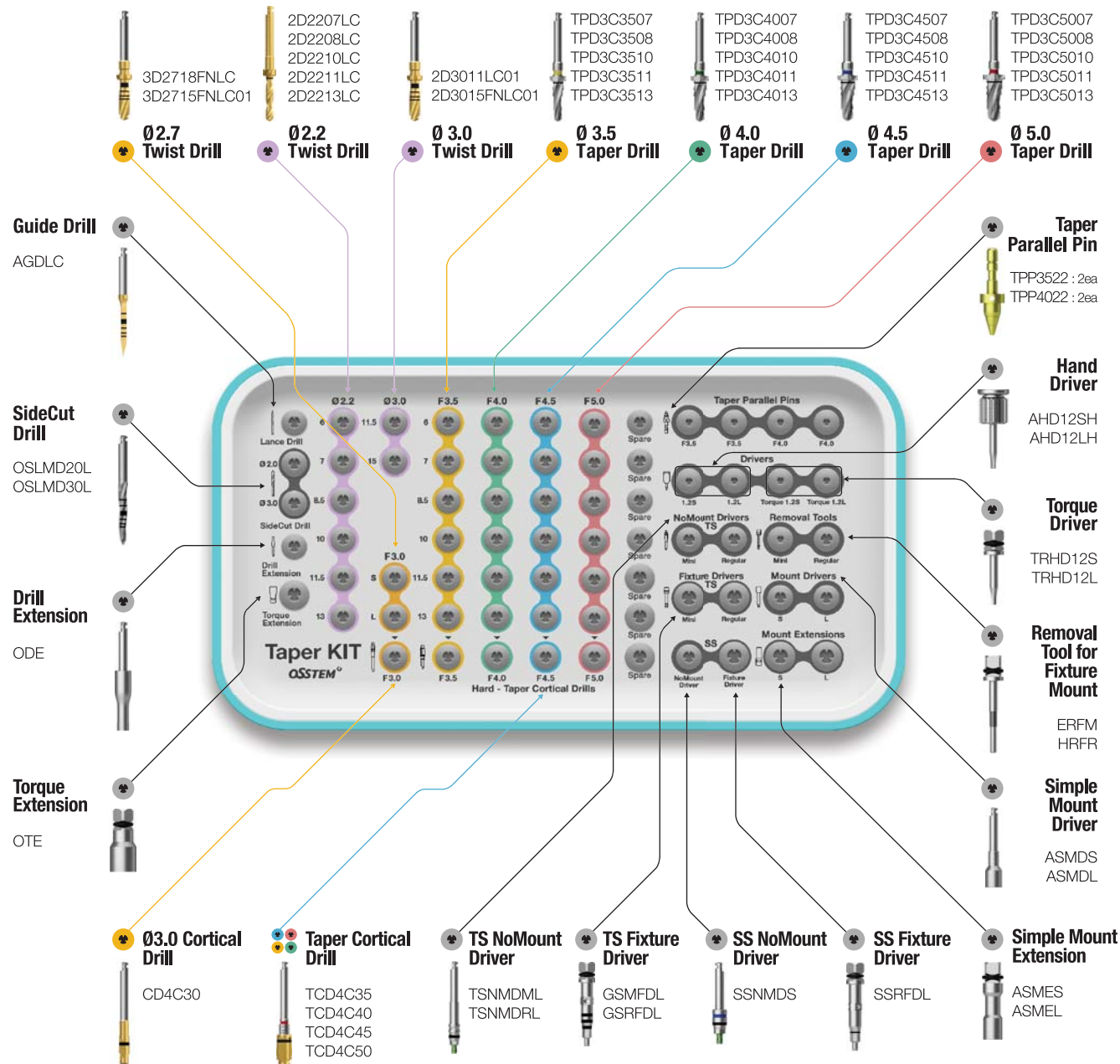

Taper Ultra KIT (HULTPK)

For **III Ultra-wide**

Lower panel components

Open Wrench
SPOW



Ratchet Wrench
RCWC

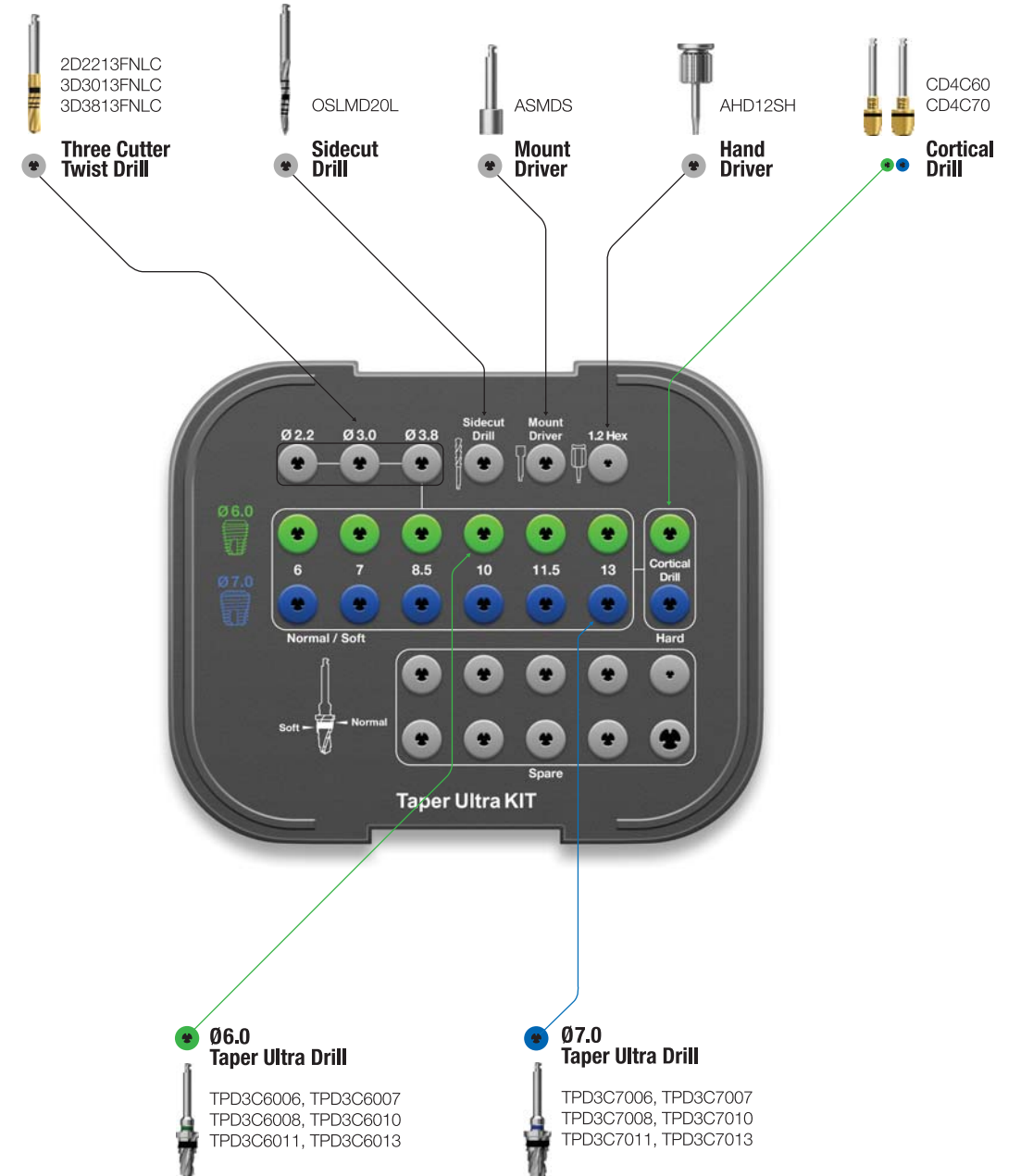

Taper KIT Surgical Instruments

Taper Drill

- Taper drill for taper(III type) fixture by diameter and length
- Stopper drill with 1mm space
- Color coding displays fixture diameter
- F3.5 : yellow, F4.0 : green, F4.5 : blue, F5.0 : red, F5.5 : yellow
- Taper KIT single item (excluded from 122 taper KIT)

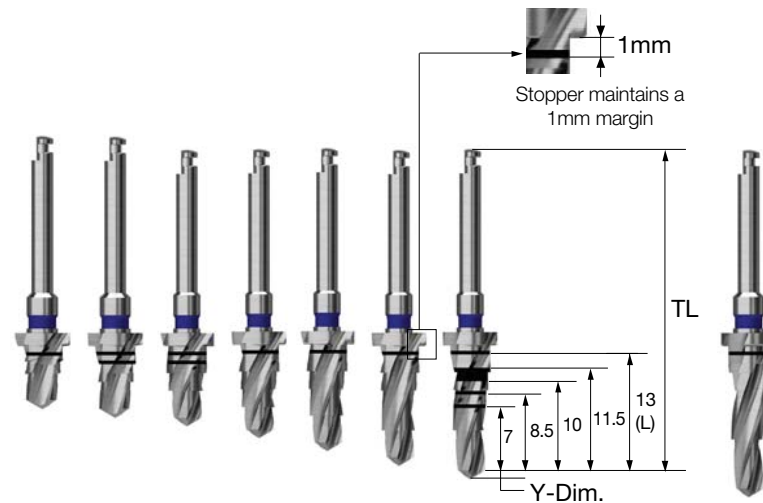

L	TL	F3.5	F4.0	F4.5	F5.0	F5.5
	Y-Dim.	0.8	0.9	1.0	1.0	1.0
5.0	29.5	TPD3C3505	TPD3C4005	TPD3C4505	TPD3C5005	-
6.0	30.5	TPD3C3506	TPD3C4006	TPD3C4506	TPD3C5006	TPD3C5506
7.0	31.5	TPD3C3507	TPD3C4007	TPD3C4507	TPD3C5007	TPD3C5507
8.5	33	TPD3C3508	TPD3C4008	TPD3C4508	TPD3C5008	TPD3C5508
10	34.5	TPD3C3510	TPD3C4010	TPD3C4510	TPD3C5010	TPD3C5510
11.5	34.5	TPD3C3511	TPD3C4011	TPD3C4511	TPD3C5011	TPD3C5511
13	36	TPD3C3513	TPD3C4013	TPD3C4513	TPD3C5013	TPD3C5513
15	38	TPD3C3515	TPD3C4015	TPD3C4515	TPD3C5015	TPD3C5515
Color		Yellow	Green	Blue	Red	Yellow

Taper Cortical Drill for Taper Fixture (TSIII, SSIII, USIII)

- Drill used to remove cortical bone at hard bone (Use immediately after taper drill)
- Dedicated drill for each fixture diameter
- F3.5~5.0 drill marking line : bottom line 8.5mm or less, top line 10mm or more fixture placement standard
- F5.5 drill marking line : bottom line 6mm or less, middle line 7mm, top line 8.5mm or more fixture placement standard
- It is recommended to drill to the bottom of the marking line
- Taper KIT single item (excluded from 122 taper KIT)
- F = Fixture



F3.5	F4.0	F4.5	F5.0	F5.5
TCD4C35	TCD4C40	TCD4C45	TCD4C50	TCD4C55

Taper Ultra Drill

- Taper drill for taper ultra-wide fixture by diameter and length
- Stopper drill with 1mm space
- Color coding displays fixture diameter
- F = Fixture

L	F6.0	F7.0
6	TPD3C6006	TPD3C7006
7	TPD3C6007	TPD3C7007
8.5	TPD3C6008	TPD3C7008
10	TPD3C6010	TPD3C7010
11.5	TPD3C6011	TPD3C7011
13	TPD3C6013	TPD3C7013
Color	Green	Blue

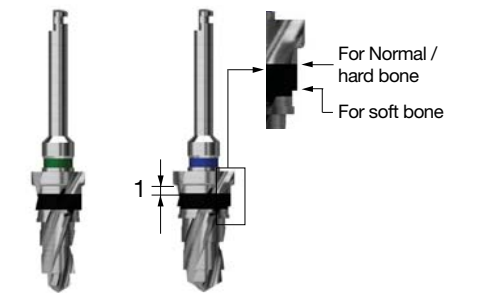

Cortical Drill for Ultra-Wide

- Drill used to remove cortical bone at hard bone (for ultra-wide)
- Dedicated drill for each fixture diameter
- It is recommended to drill to the bottom of the marking line
- F = Fixture

F6.0	F7.0
CD4C60	CD4C70

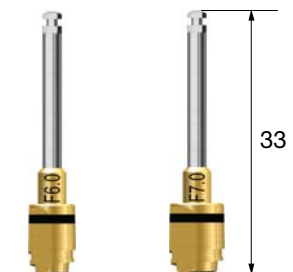

Parallel Pin for Taper Drill

- Parallel pin for taper drill
- Used for checking position and direction of bone preparation
- The lower part is for fixture diameter drill and the upper part is for initial drill
- Color coding by fixture diameter (F3.5 : yellow, F4.0 : green, F4.5 : blue, F5.0 : silver)
- 122 taper & taper KIT common components

F3.5	F4.0	F4.5	F5.0
TPP3522	TPP4022	TPP4522	TPP5022

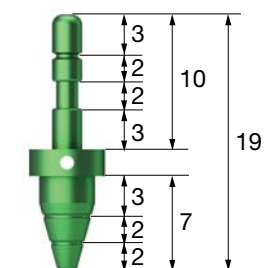

Taper KIT Surgical Instruments

Tapered Fixture Tap for TSIII, USIII, SSIII SA

- Tap for tapered fixture (III type)
- Used in hard bone and forming fixture screw thread
- Engine (25rpm recommended) or torque wrench after mount extension fastening
- Taping to the bottom of the marking line is recommended.
(for F5.0, the bottom line below 7.0mm fixture and the upper line over 8.5mm fixture placement standard)
- F = Fixture

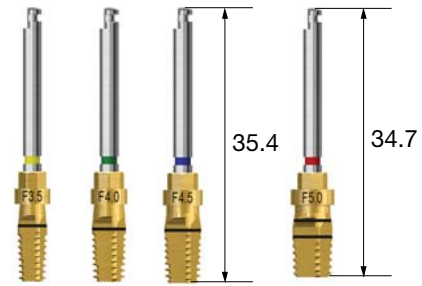

F3.5	F4.0	F4.5	F5.0
OFTS35	OFTS40	OFTS45	OFTS50

※ Refer to surgical instruments for other components (106p-)

OSSTEM[®]
IMPLANT

Drilling Sequence Taper Drill

TSIII | SSIII | USIII

(Length : 10mm)

Ø3.0mm

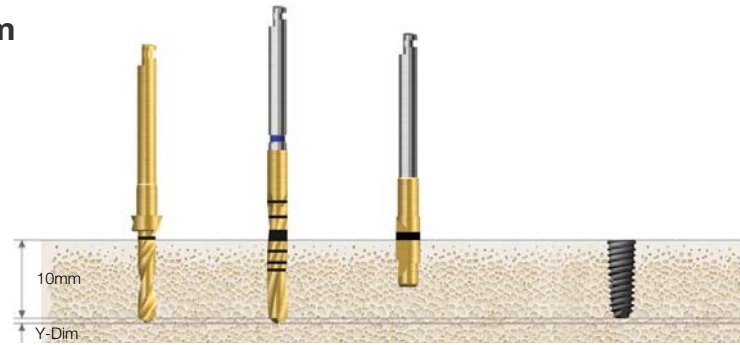

Bone Quality	Ø 2.2 Drill	Ø 2.7 Drill	F3.0 Cortical Drill	Ø 3.0 Fixture
Soft	▶			
Normal	▶	▶		Implant Placement
Hard	▶	▶	▶	

Ø3.5mm

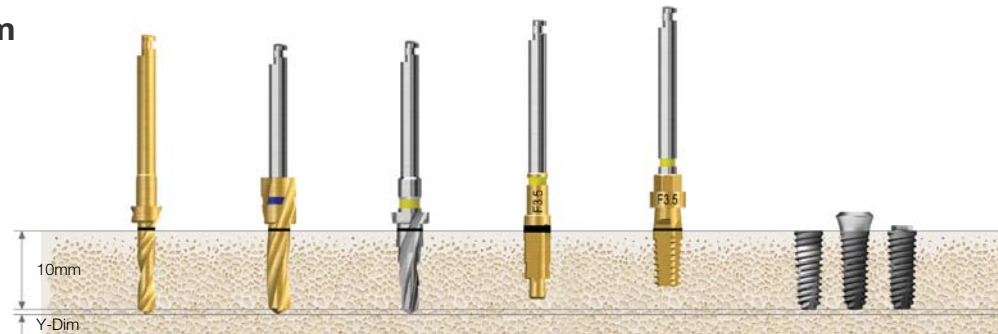

Bone Quality	Ø 2.2 Drill	Ø 3.0 Drill	F3.5 Taper Drill	F3.5 Taper Cortical Drill	F3.5 Taper Fixture Tap	Ø 3.5 Fixture
Soft	▶	▶				
Normal	▶		▶			Implant Placement
Hard	▶		▶	▶		
Hard (Option)	▶		▶		▶	

Ø4.0mm

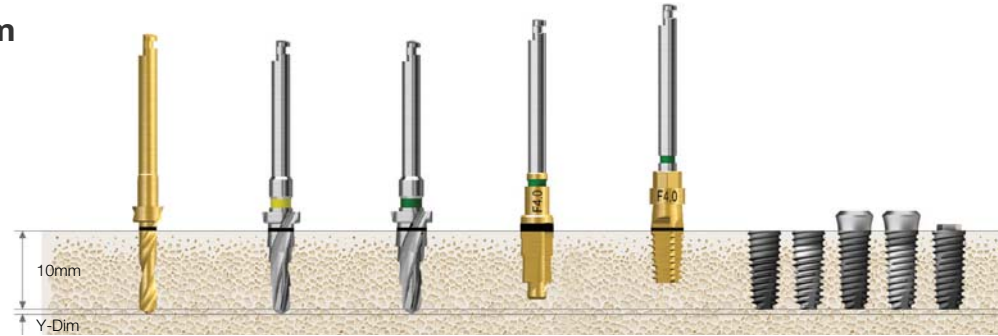

Bone Quality	Ø 2.2 Drill	F3.5 Taper Drill	F4.0 Taper Drill	F4.0 Taper Cortical Drill	F4.0 Taper Fixture Tap	Ø 4.0 Fixture
Soft	▶	▶				
Normal	▶	▶	▶			Implant Placement
Hard	▶	▶	▶	▶		
Hard (Option)	▶	▶	▶		▶	

Taper cortical drill marking line Bottom line 8.5mm or more, top line 10mm or more fixture placement standard

Recommended placement torque Below than 40Ncm, TSIII/SSIII HA : below than 35Ncm (In hard bone, HA coating layer cracking and peeling can occur)

TS fixture placement depth The normal bone is placed 1mm deeper than bone level, and the soft bone is placed at the bone level to maintain the fixed strength

Fixture tap used in hard bone : engine (25rpm recommended) or torque wrench after mount extension fastening

(F5.0 fixture tap : bottom line 7mm or less, top line 8.5mm or more fixture placement standard)

Ø4.5mm

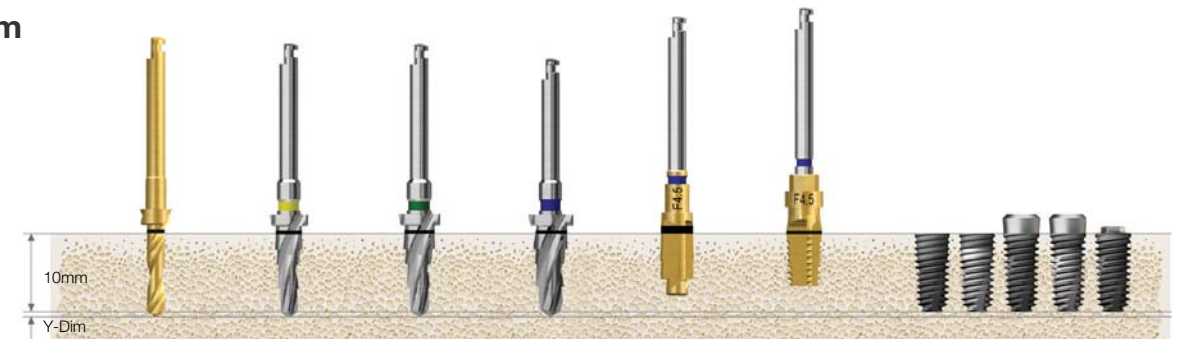

Bone Quality	Ø 2.2 Drill	F3.5 Taper Drill	F4.0 Taper Drill	F4.5 Taper Drill	F4.5 Taper Cortical Drill	F4.5 Taper Fixture Tap	Ø 4.5 Fixture
Soft	▶	▶	▶				
Normal	▶	▶		▶			Implant Placement
Hard	▶	▶		▶	▶		
Hard (Option)	▶	▶		▶		▶	

Ø5.0mm

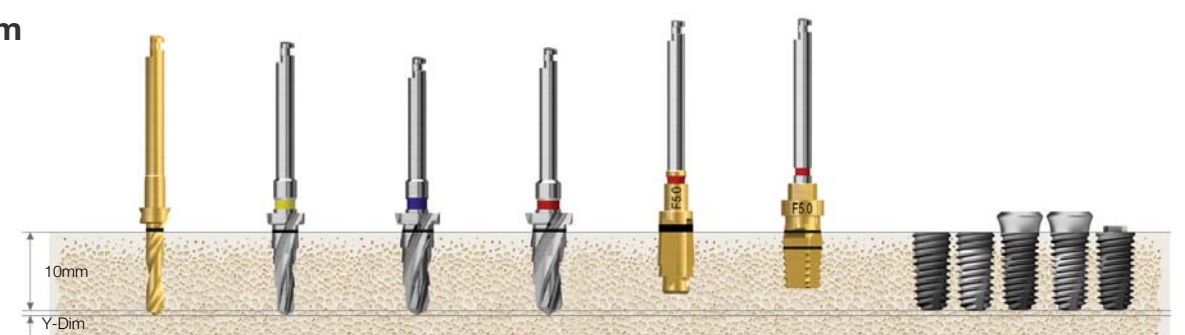

Bone Quality	Ø 2.2 Drill	F3.5 Taper Drill	F4.5 Taper Drill	F5.0 Taper Drill	F5.0 Taper Cortical Drill	F5.0 Taper Fixture Tap	Ø 5.0 Fixture
Soft	▶	▶	▶				
Normal	▶	▶	▶	▶			Implant Placement
Hard	▶	▶	▶	▶	▶		
Hard (Option)	▶	▶	▶	▶		▶	

Ø5.5mm

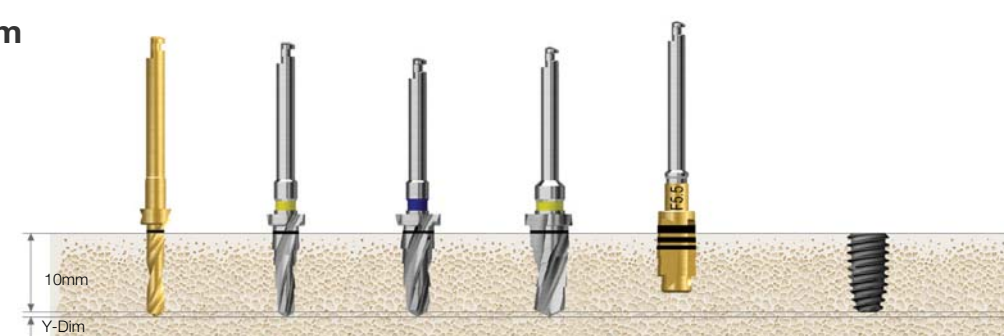

Bone Quality	Ø 2.2 Drill	F3.5 Taper Drill	F4.5 Taper Drill	F5.5 Taper Drill	F5.5 Taper Fixture Tap	Ø 5.5 Fixture
Soft	▶	▶	▶			
Normal	▶	▶	▶	▶		Implant Placement
Hard	▶	▶	▶	▶	▶	

Drilling Sequence Taper Drill

TSIV | USIV

(Length : 10mm)

Ø4.0mm

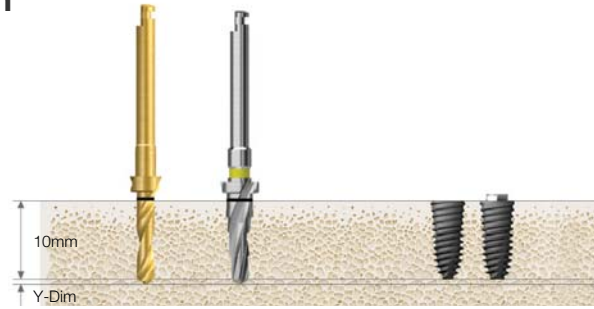

Bone Quality	Ø 2.2 Drill	F3.5 Taper Drill	Ø 4.0 Fixture
D4	▶	▶	Implant Placement
Soft	▶	▶	

Ø4.5mm

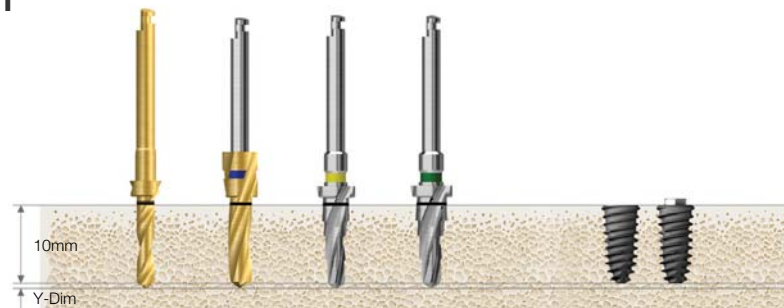

Bone Quality	Ø 2.2 Drill	Ø 3.0 Drill	F3.5 Taper Drill	F4.0 Taper Drill	Ø 4.5 Fixture
D4		▶			Implant Placement
Soft	▶		▶	▶	

Ø5.0mm

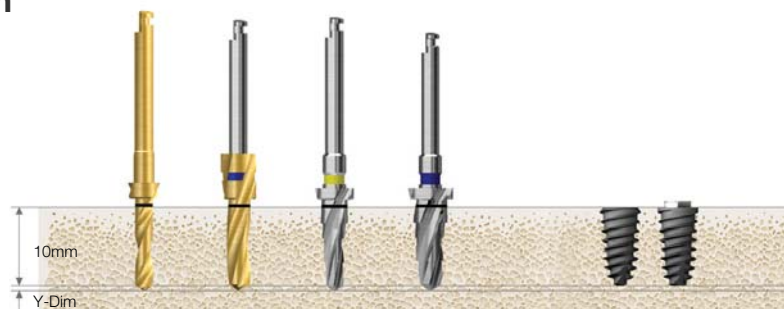

Bone Quality	Ø 2.2 Drill	Ø 3.0 Drill	F3.5 Taper Drill	F4.5 Taper Drill	Ø 5.0 Fixture
D4		▶			Implant Placement
Soft	▶		▶	▶	

Drilling Sequence Taper Drill

TSIII Ultra-wide | SSIII Ultra-wide | USIII Ultra-wide

(Length : 10mm)

Ø6.0mm

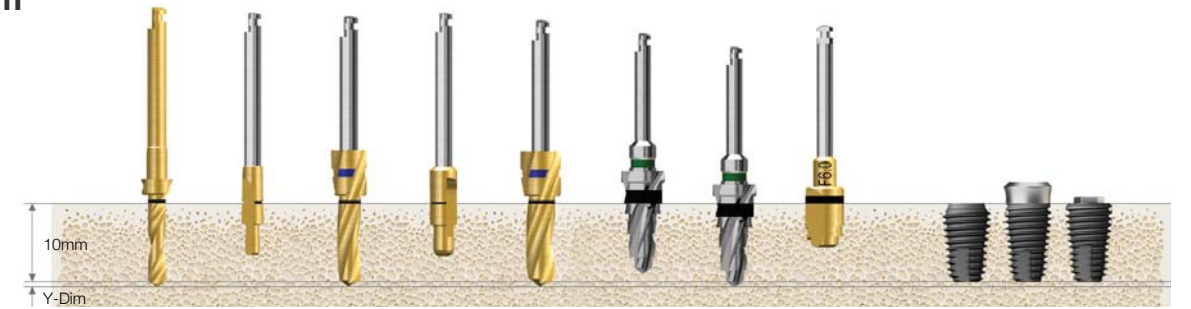

Bone Quality	Ø 2.2 Drill	Ø 2.0/3.0 Pilot Drill	Ø 3.0 Drill	Ø 3.0/3.8 Pilot Drill	Ø 3.8 Drill	F6.0 Taper Drill	F6.0 Taper Drill	F6.0 Cortical Drill	Ø 6.0 Fixture
Soft	▶	▶	▶	▶		▶			Implant Placement
Normal	▶	▶	▶	▶	▶		▶		
Hard	▶	▶	▶	▶	▶		▶	▶	

Ø7.0mm

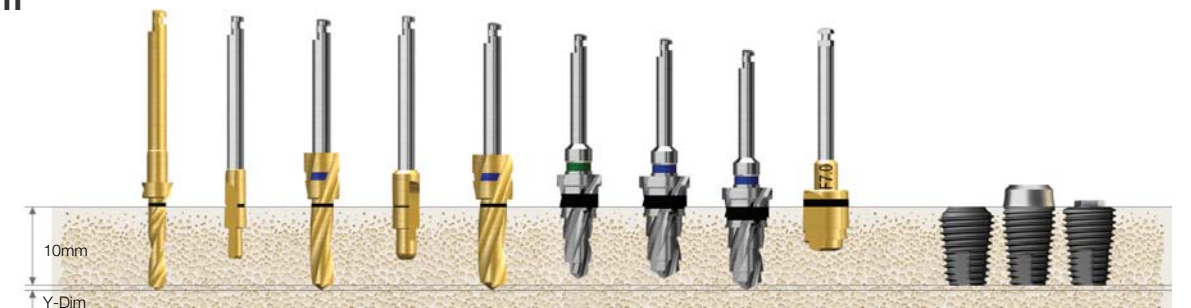

Bone Quality	Ø 2.2 Drill	Ø 2.0/3.0 Pilot Drill	Ø 3.0 Drill	Ø 3.0/3.8 Pilot Drill	Ø 3.8 Drill	F6.0 Taper Drill	F7.0 Taper Drill	F7.0 Taper Drill	F7.0 Cortical Drill	Ø 7.0 Fixture
Soft	▶	▶	▶	▶		▶	▶			Implant Placement
Normal	▶	▶	▶	▶	▶			▶		
Hard	▶	▶	▶	▶	▶			▶	▶	

Recommended placement torque Below than 40Ncm

TS fixture placement depth The normal/hard bone is placed 1mm deeper than bone level, and the soft bone is placed at the bone level to maintain the fixed strength

Drilling Sequence Taper Drill

TSIV Ultra-wide

(Length : 10mm)

Ø6.0mm

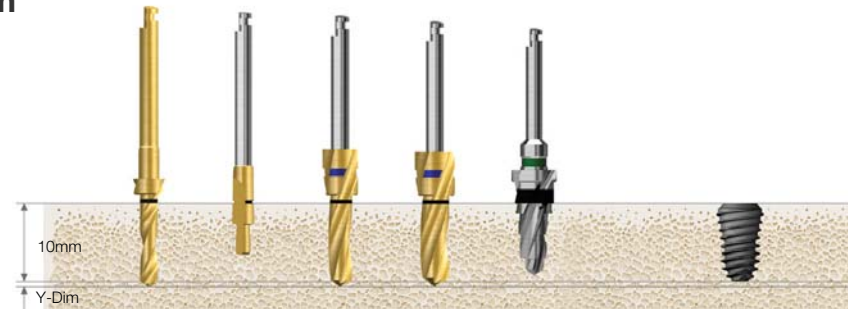

Bone Quality	Ø 2.2 Drill	Ø 2.0/3.0 Pilot Drill	Ø 3.0 Drill	Ø 3.8 Drill	F6.0 Taper Drill	Ø 6.0 Fixture
D4	▶			▶		Implant Placement
Soft	▶	▶	▶		▶	

Ø7.0mm

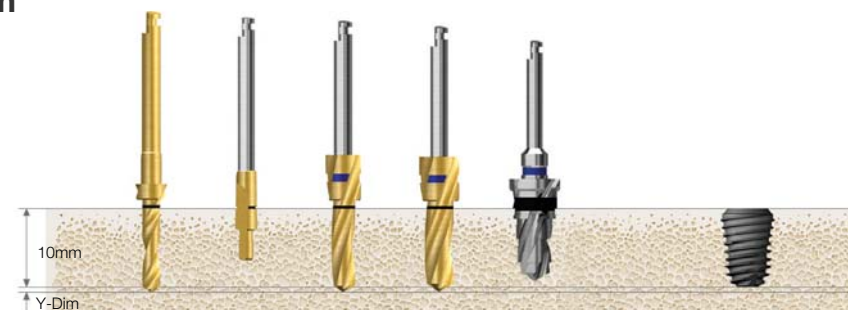

Bone Quality	Ø 2.2 Drill	Ø 2.0/3.0 Pilot Drill	Ø 3.0 Drill	Ø 3.8 Drill	F7.0 Taper Drill	Ø 7.0 Fixture
D4	▶			▶		Implant Placement
Soft	▶	▶	▶		▶	

OSSTEM[®]
IMPLANT

Recommended placement torque Below than 40Ncm

TS fixture placement depth The normal/hard bone is placed 1mm deeper than bone level, and the soft bone is placed at the bone level to maintain the fixed strength

123 Straight Simple KIT (O123K)

123 Straight Simple KIT Surgical Instruments

For **TSII / III** **SSII / III** **USII / III**

Top panel components

Torque Wrench
TW30B



Depth Gauge
OSDG

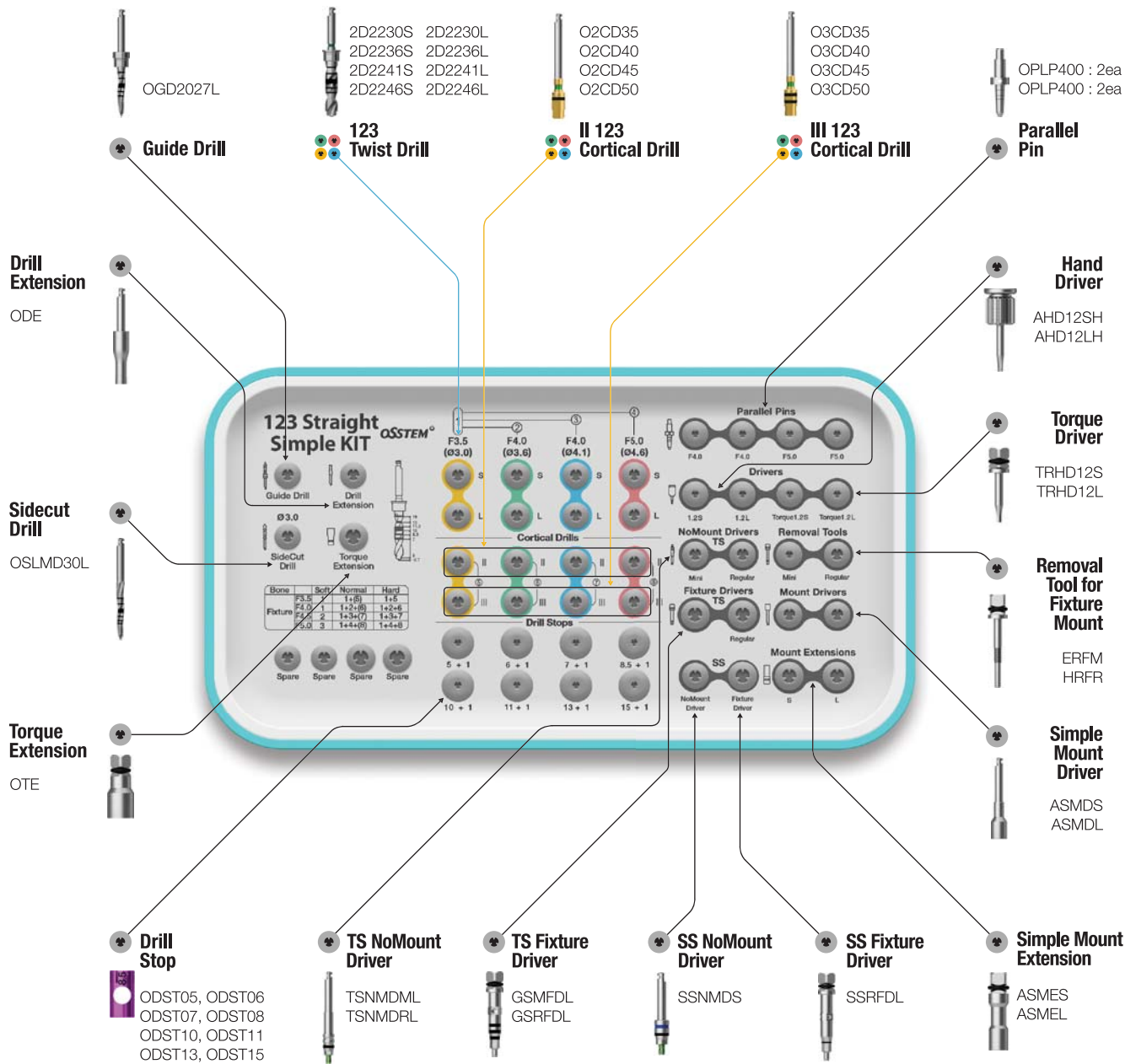

123 Twist Drill

- A straight drill(marking drill) that reduces sequences
- 123 drill color coding shows diameter and main fixture used
- Easy to adjust drilling depth as desired by fastening stopper
- Be sure to use stopper as it can be difficult to control the depth due to excellent cutting force
- F = Fixture

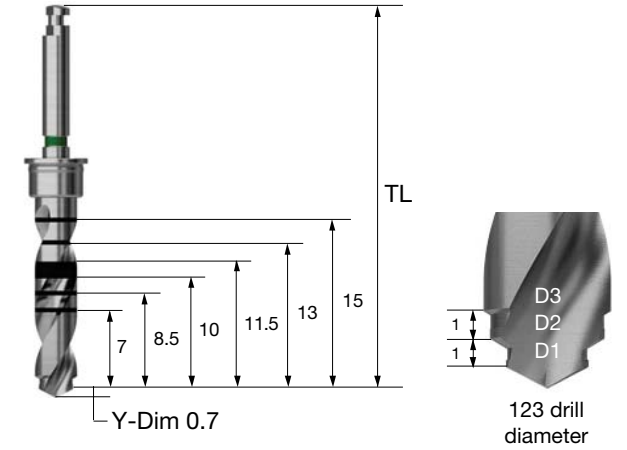

TL	D1 / D2 / D3			
	F3.5(Ø2.2 / 3.0)	F4.0(Ø3.0 / 3.6)	F4.5(Ø3.0 / 3.6 / 4.1)	F5.0(Ø3.0 / 4.1 / 4.6)
34	2D2230S	2D3036S	2D3041S	2D3046S
40.4	2D2230L	2D3036L	2D3041L	2D3046L
Color	Yellow	Green	Blue	Red

123 Drill Stopper

- The stopper number is the length of the tip protruding when drill or instrument is tightened
- Length-based color coding makes it easy to grasp the length



123 Straight Simple KIT Surgical Instruments

123 Cortical Drill

- Drill used to remove cortical bone from hard bone
- Recommend drilling to bottom line of marking line
- II type marking line : hard bone standard
- III type marking line : lower line normal bone, upper line hard bone standard
- IV type marking line : normal bone standard
- Color coding displays diameter and main fixture used
- F = Fixture

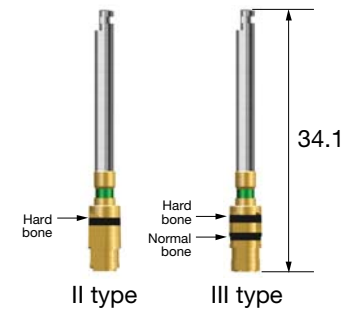

Type	F3.5	F4.0	F4.5	F5.0
II	O2CD35	O2CD40	O2CD45	O2CD50
III	O3CD35	O3CD40	O3CD45	O3CD50
Color	Yellow	Green	Blue	Red

※ Refer to surgical instruments for other components (106p-)

OSSTEM[®]
IMPLANT

123 Straight KIT (O123FK)

123 Straight Full KIT (O123STFK)

For **TSII / III** **SSII / III** **USII / III**

For **TSIII / IV** **SSIII** **USIII / IV** **III / IV Ultra-wide**

Top panel components

Torque Wrench
TW30B



Depth Gauge
OSDG

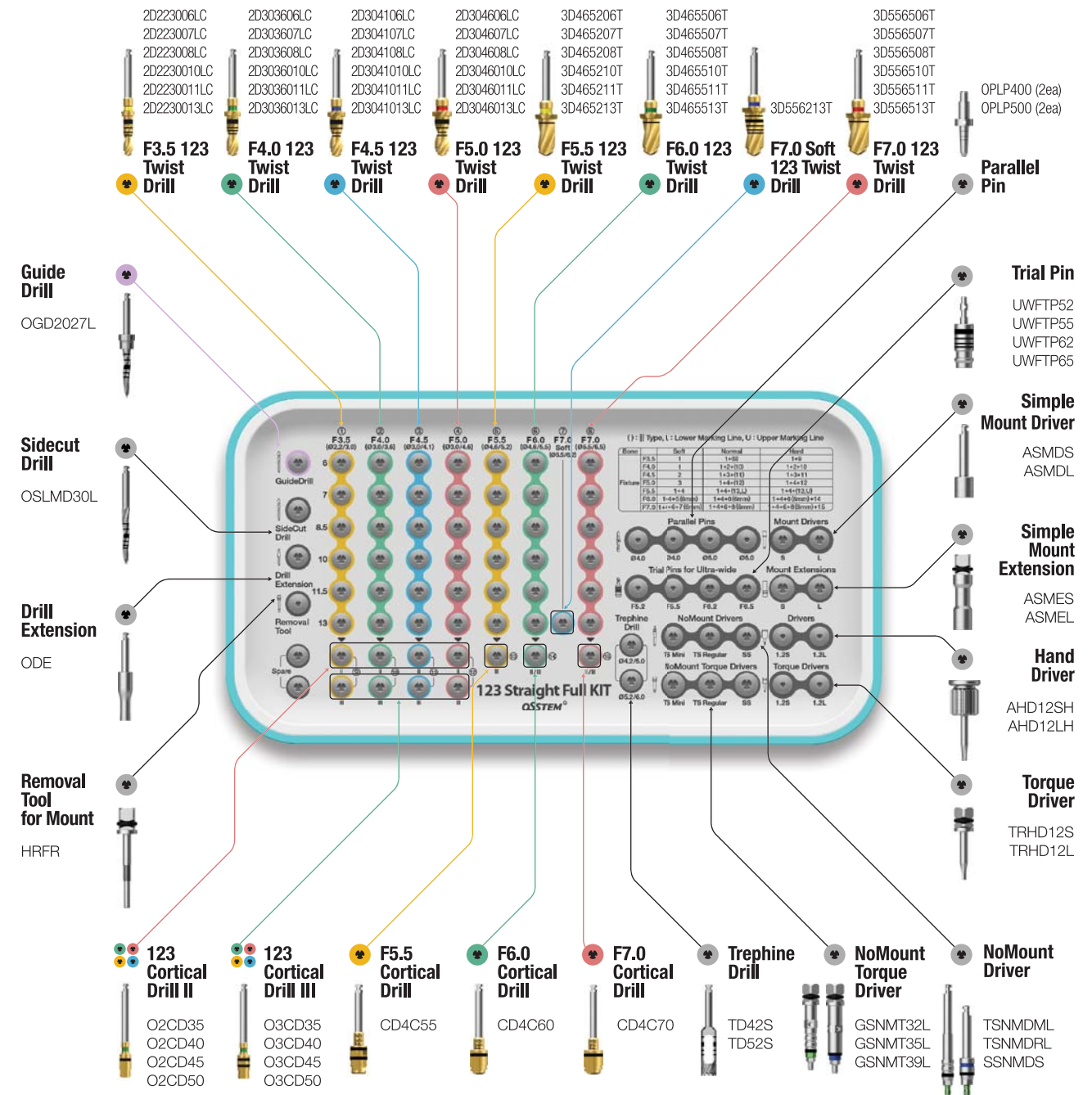
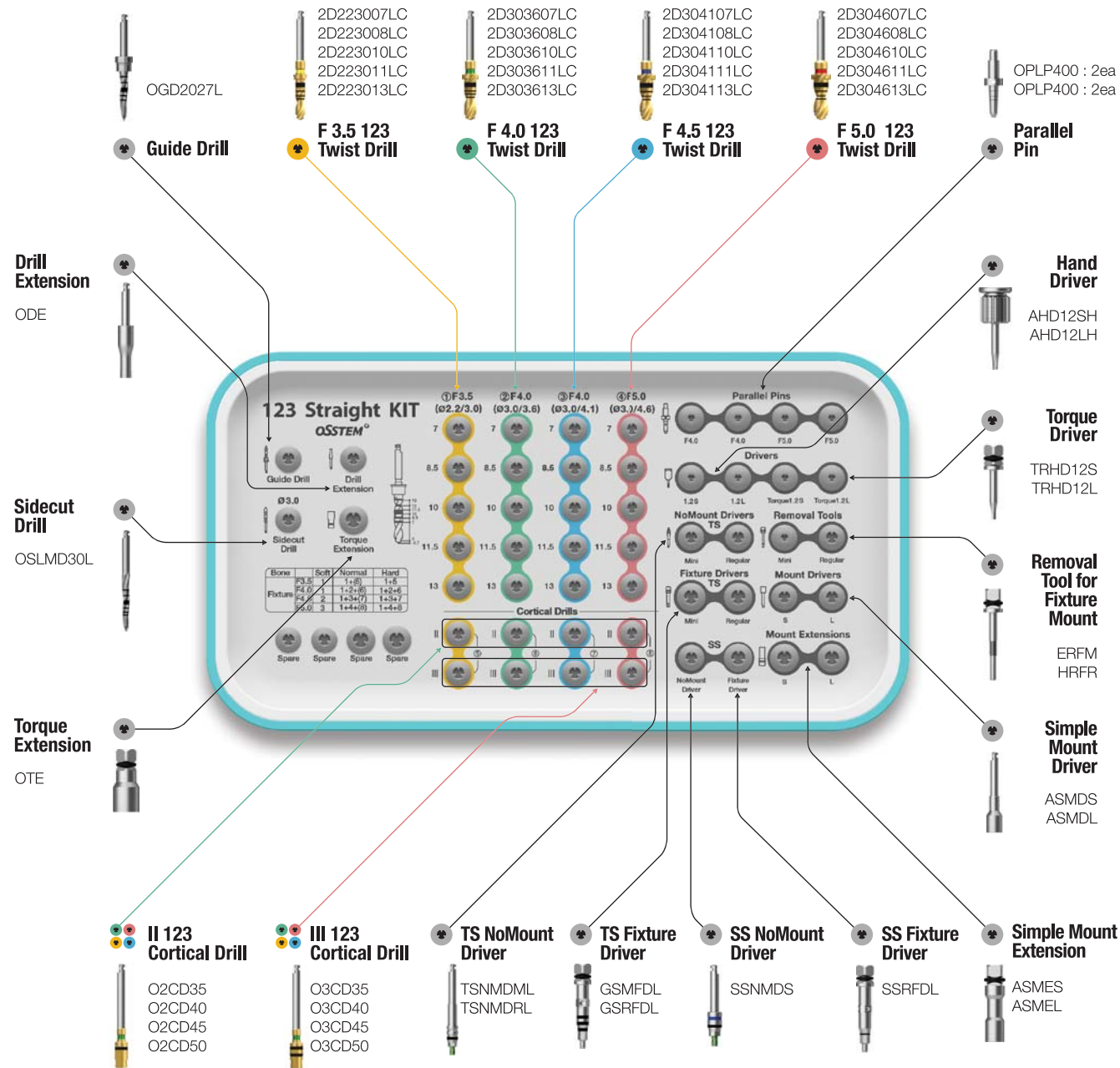

123 Straight KIT Surgical Instruments

123 Twist Drill - Stopper Drill

- A straight drill (it has stopper) to shorten the number of drilling
- 123 drill color coding shows diameter and main fixture used
- F = Fixture

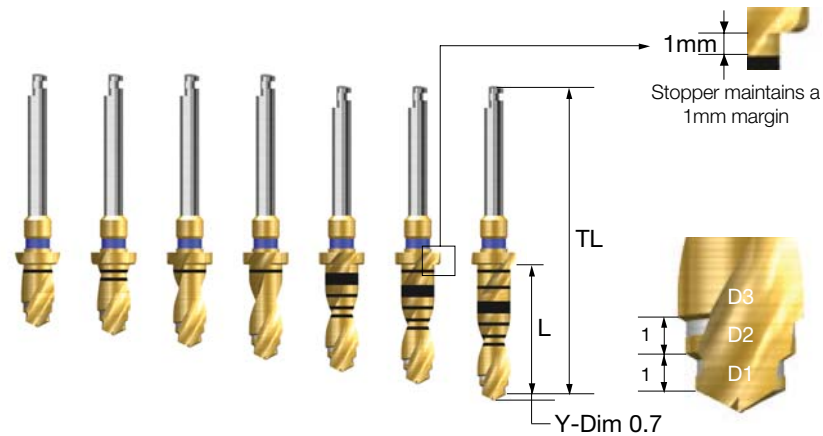

L	TL	D1 / D2 / D3			
		F3.5(Ø2.2 / 3.0)	F4.0(Ø3.0 / 3.6)	F4.5(Ø3.0 / 3.6 / 4.1)	F5.0(Ø3.0 / 4.1 / 4.6)
6	30.5	2D223006LC	2D303606LC	2D304106LC	2D304606LC
7	31.5	2D223007LC	2D303607LC	2D304107LC	2D304607LC
8.5	33	2D223008LC	2D303608LC	2D304108LC	2D304608LC
10	34.5	2D223010LC	2D303610LC	2D304110LC	2D304610LC
11.5	34.5	2D223011LC	2D303611LC	2D304111LC	2D304611LC
13	36	2D223013LC	2D303613LC	2D304113LC	2D304613LC
15	38	2D223015LC	2D303615LC	2D304115LC	2D304615LC
Color		Yellow	Green	Blue	Red

123 Ultra Twist Drill

- Two-stage drill with both pilot drill and twist drill
- A straight drill (it has stopper) to shorten the number of drilling
- F7.0 fixture on soft bone uses dedicated drill
- F = Fixture

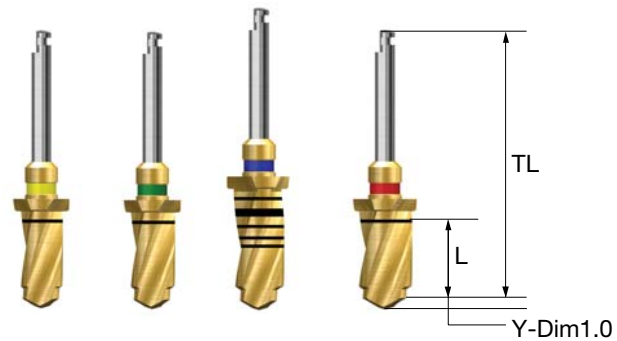

L	TL	F3.5(Ø4.6 / 5.2) F6.0(Ø4.6 / 5.5) F7.0 Soft(Ø5.5 / 6.2) F7.0(Ø5.5 / 6.5)			
		6	30.5	3D465206T	3D465506T
7	31.5	3D465207T	3D465507T	-	3D556507T
8.5	33.5	3D465208T	3D465508T	-	3D556508T
10	34.5	3D465210T	3D465510T	-	3D556510T
11.5	34.5	3D465211T	3D465511T	-	3D556511T
13	36.0	3D465213T	3D465513T	3D556213T	3D556513T
Color		Yellow	Green	Blue	Red

123 Cortical Drill

- Drill used to remove cortical bone from hard bone
- Recommend drilling to bottom line of marking line
- II type marking line : hard bone standard
- III type marking line : lower line normal bone, upper line hard bone standard
- IV type marking line : normal bone standard
- Color coding displays diameter and main fixture used
- F = Fixture

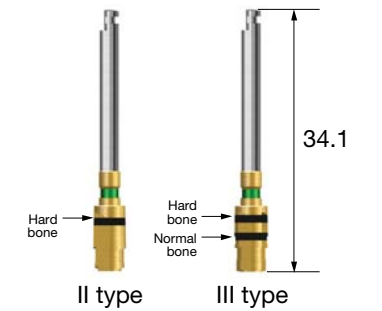

Type	F3.5	F4.0	F4.5	F5.0
II	O2CD35	O2CD40	O2CD45	O2CD50
III	O3CD35	O3CD40	O3CD45	O3CD50
Color	Yellow	Green	Blue	Red

Parallel Pin for 123 Drill

- Parallel pin for 123 twist drill
- Used to check position and orientation of bone preparation
- Lower end for initial drill, upper end for F3.5 (Ø 2.2/3.0) drill

D	Ø4.0	Ø5.0
	OPLP400	OPLP500

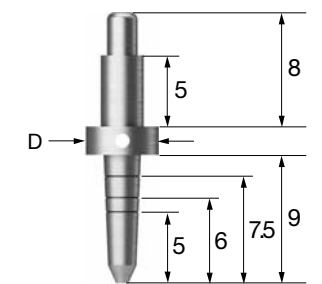

Trial Pin for Ultra-wide

- Checking the width and depth inside and outside the failed implant socket
- Use direct drill as final drill and check drilling depth
- Parallel pin purpose

D	Ø5.2	Ø5.5	Ø6.2	Ø6.5
	UWFTP52	UWFTP55	UWFTP62	UWFTP65

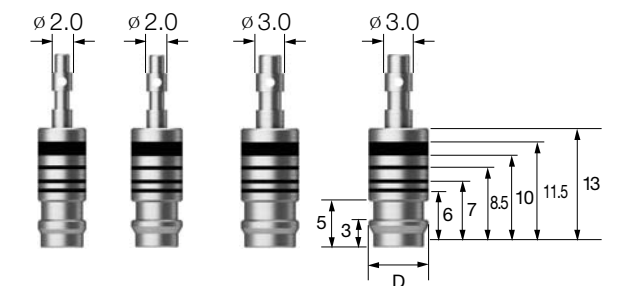

※ Refer to surgical instruments for other components (106p-)

Drilling Sequence II Type 123 Twist Drill

TSII | SSII | USII

(Length : 10mm)

Ø3.5mm



Bone Quality	Guide Drill	Ø 2.2/3.0 Drill	Cortical Drill	Ø 3.5 Fixture
Soft	▶	▶		
Normal	▶	▶		Implant Placement
Hard	▶	▶	▶	

Ø5.0mm

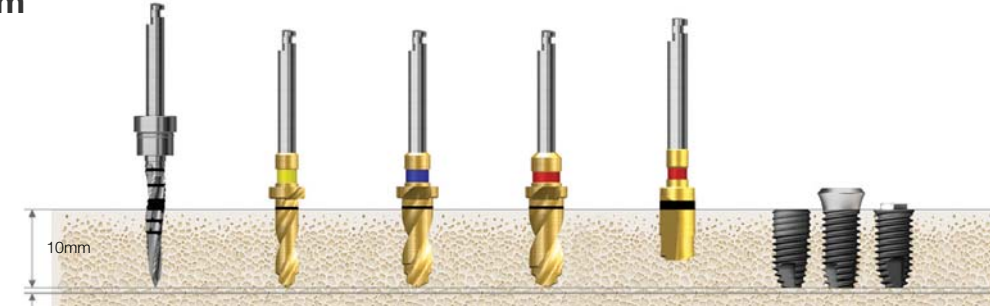

Bone Quality	Guide Drill	Ø 2.2/3.0 Drill	Ø 3.0/4.1 Drill	Ø 3.0/4.6 Drill	Cortical Drill	Ø 5.0 Fixture
Soft	▶		▶			
Normal	▶	▶		▶		Implant Placement
Hard	▶	▶		▶	▶	

Ø4.0mm

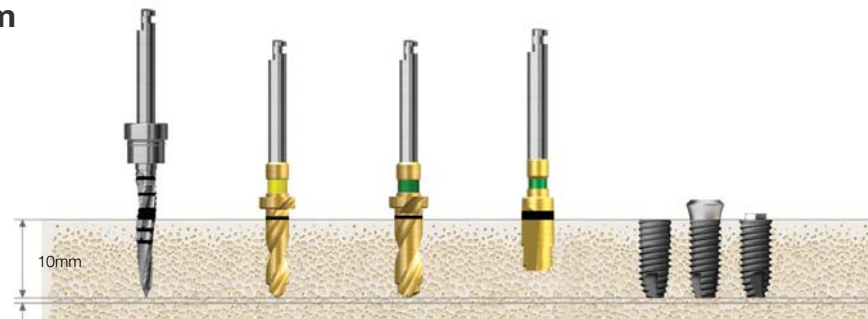

Bone Quality	Guide Drill	Ø 2.2/3.0 Drill	Ø 3.0/3.6 Drill	Cortical Drill	Ø 4.0 Fixture
Soft	▶	▶			
Normal	▶	▶	▶		Implant Placement
Hard	▶	▶	▶	▶	

Ø4.5mm

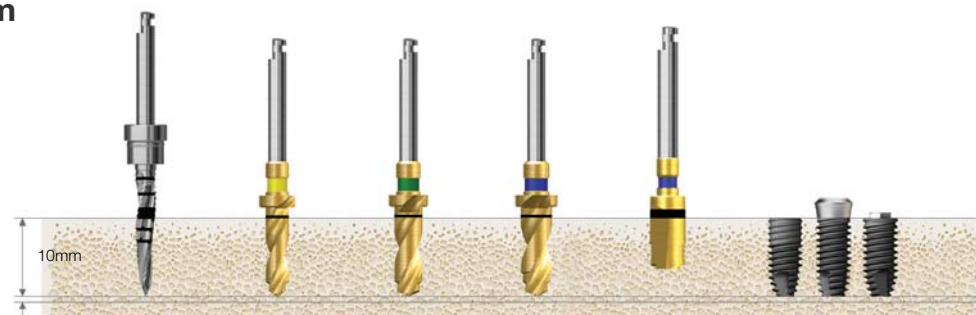

Bone Quality	Guide Drill	Ø 2.2/3.0 Drill	Ø 3.0/3.6 Drill	Ø 3.0/4.1 Drill	Cortical Drill	Ø 4.5 Fixture
Soft	▶		▶			
Normal	▶	▶		▶		Implant Placement
Hard	▶	▶		▶	▶	

Drilling Sequence III Type 123 Twist Drill

TSIII | SSIII | USIII

(Length : 10mm)

Ø3.5mm

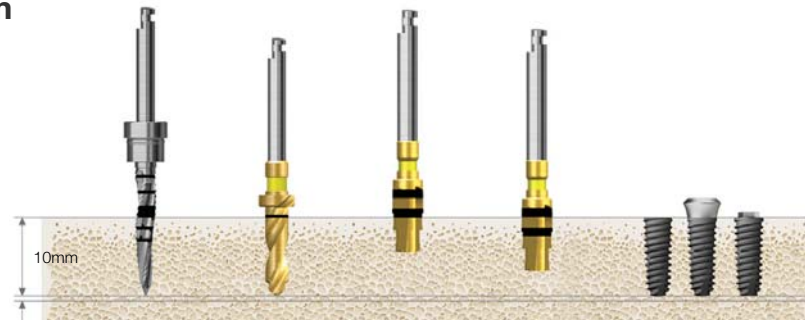

Bone Quality	Guide Drill	Ø 2.2/3.0 Drill	F3.5 Cortical Drill (Bottom Line)	F3.5 Cortical Drill (Upper Line)	Ø 3.5 Fixture
Soft	▶	▶			
Normal	▶	▶	▶		Implant Placement
Hard	▶	▶		▶	

Ø5.0mm

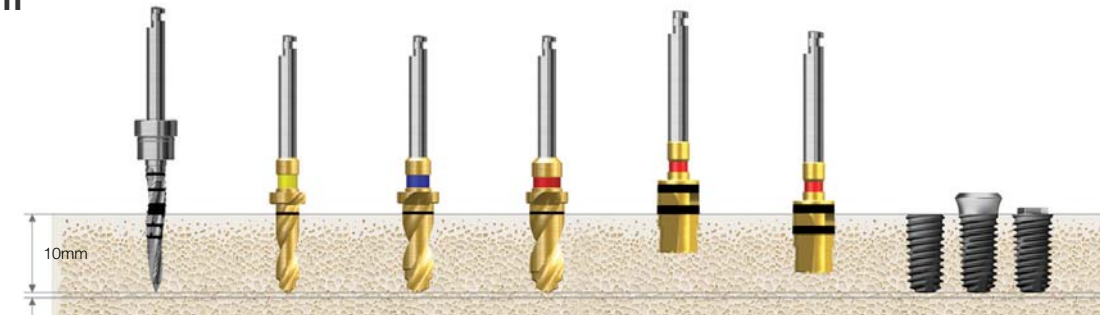

Bone Quality	Guide Drill	Ø 2.2/3.0 Drill	Ø 3.0/4.1 Drill	Ø 3.0/4.6 Drill	F5.0 Cortical Drill (Bottom Line)	F5.0 Cortical Drill (Upper Line)	Ø 5.0 Fixture
Soft	▶		▶				
Normal	▶	▶		▶	▶		Implant Placement
Hard	▶	▶		▶		▶	

Ø4.0mm

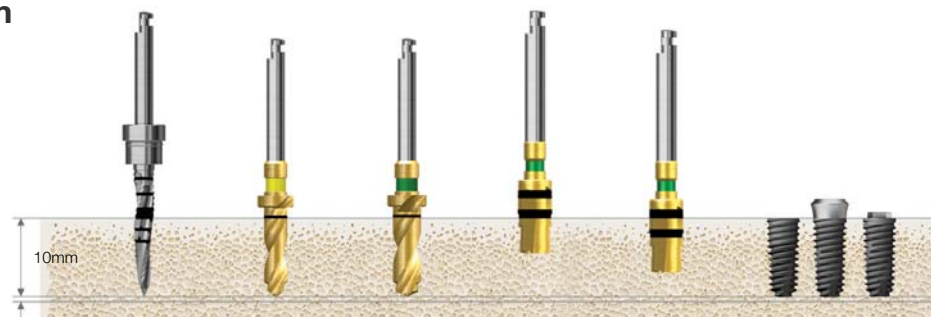

Bone Quality	Guide Drill	Ø 2.2/3.0 Drill	Ø 3.0/3.6 Drill	F4.0 Cortical Drill (Bottom Line)	F4.0 Cortical Drill (Upper Line)	Ø 4.0 Fixture
Soft	▶	▶				
Normal	▶	▶	▶	▶		Implant Placement
Hard	▶	▶	▶		▶	

Ø5.5mm

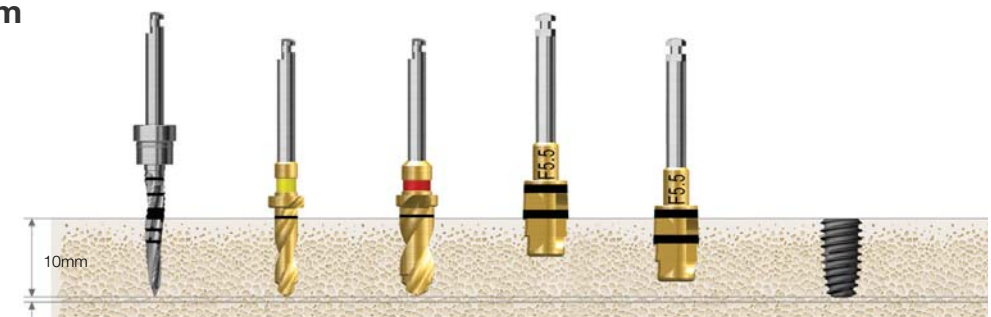

Bone Quality	Guide Drill	Ø 2.2/3.0 Drill	Ø 3.0/4.6 Drill	F5.5 Cortical Drill (Bottom Line)	F5.5 Cortical Drill (Upper Line)	Ø 5.5 Fixture
Soft	▶	▶	▶			
Normal	▶	▶	▶	▶		Implant Placement
Hard	▶	▶	▶		▶	

Ø4.5mm

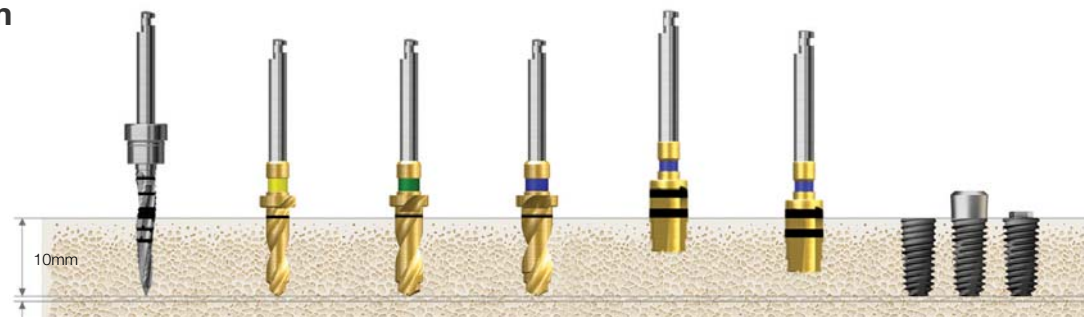

Bone Quality	Guide Drill	Ø 2.2/3.0 Drill	Ø 3.0/3.6 Drill	Ø 3.0/4.1 Drill	F4.5 Cortical Drill (Bottom Line)	F5.0 Cortical Drill (Upper Line)	Ø 4.5 Fixture
Soft	▶		▶				
Normal	▶	▶		▶	▶		Implant Placement
Hard	▶	▶		▶		▶	

Drilling Sequence **Ultra-wide 123 Twist Drill**

TSII Ultra-wide | SSII Ultra-wide | USII Ultra-wide

(Length : 10mm)

Ø6.0mm

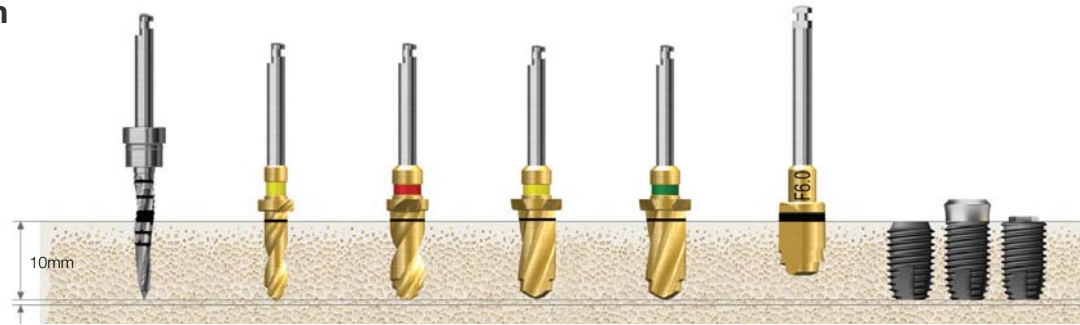

Bone Quality	Guide Drill	Ø 2.0/3.0 Drill	Ø 3.0/4.6 Drill	Ø 4.6/5.2 Drill	Ø 4.6/5.5 Drill	F6.0 Cortical Drill	Ø 6.0 Fixture
Soft	▶	▶	▶	▶			
Normal	▶	▶	▶		▶		Implant Placement
Hard	▶	▶	▶		▶	▶	

Ø7.0mm

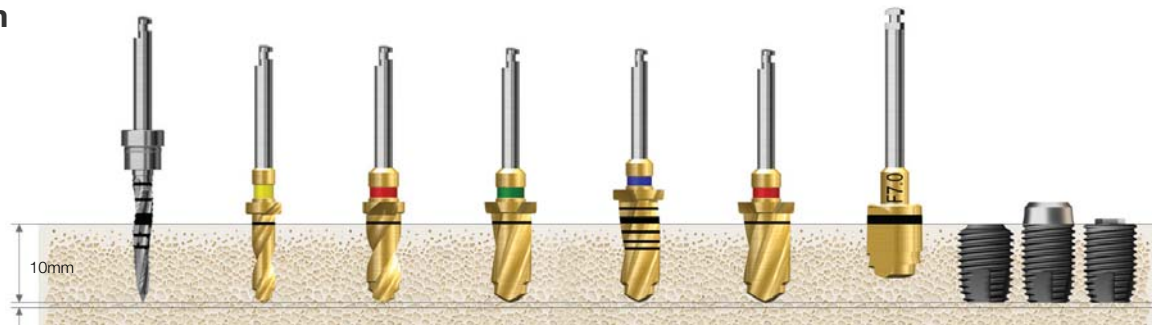

Bone Quality	Guide Drill	Ø 2.0/3.0 Drill	Ø 3.0/4.6 Drill	Ø 4.6/5.5 Drill	Ø 5.5/6.2 Drill (F7.0 Soft)	Ø 5.5/6.5 Drill	F7.0 Cortical Drill	Ø 7.0 Fixture
Soft	▶	▶	▶	▶	▶			
Normal	▶	▶	▶	▶		▶		Implant Placement
Hard	▶	▶	▶	▶		▶	▶	

Drilling Sequence **Ultra-wide 123 Twist Drill**

TSIII Ultra-wide | SSIII Ultra-wide | USIII Ultra-wide

(Length : 10mm)

Ø6.0mm

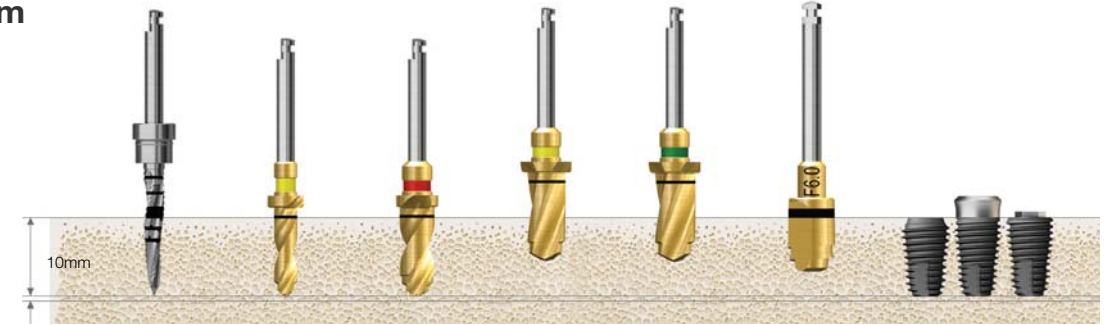

Bone Quality	Guide Drill	Ø 2.0/3.0 Drill	Ø 3.0/4.6 Drill	Ø 4.6/5.2 Drill	Ø 4.6/5.5 Drill	F6.0 Cortical Drill	Ø 6.0 Fixture
Soft	▶	▶	▶	▶(6mm)			
Normal	▶	▶	▶		▶(6mm)		Implant Placement
Hard	▶	▶	▶		▶(6mm)	▶	

Ø7.0mm

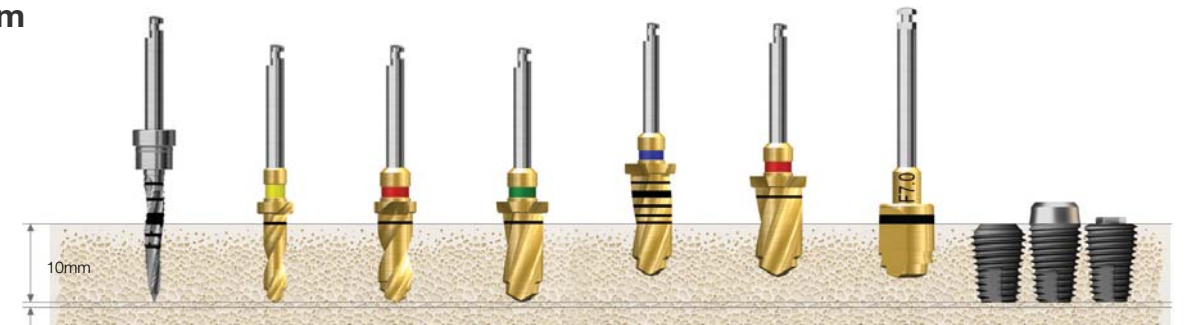

Bone Quality	Guide Drill	Ø 2.0/3.0 Drill	Ø 3.0/4.6 Drill	Ø 4.6/5.5 Drill	Ø 5.5/6.2 Drill (F7.0 Soft)	Ø 5.5/6.5 Drill	F7.0 Cortical Drill	Ø 7.0 Fixture
Soft	▶	▶	▶	▶	▶(6mm)			
Normal	▶	▶	▶	▶		▶(6mm)		Implant Placement
Hard	▶	▶	▶	▶		▶(6mm)	▶	

New Hanaro KIT (HKA2)

For **TSII / III** **SSII / III** **USII / III**

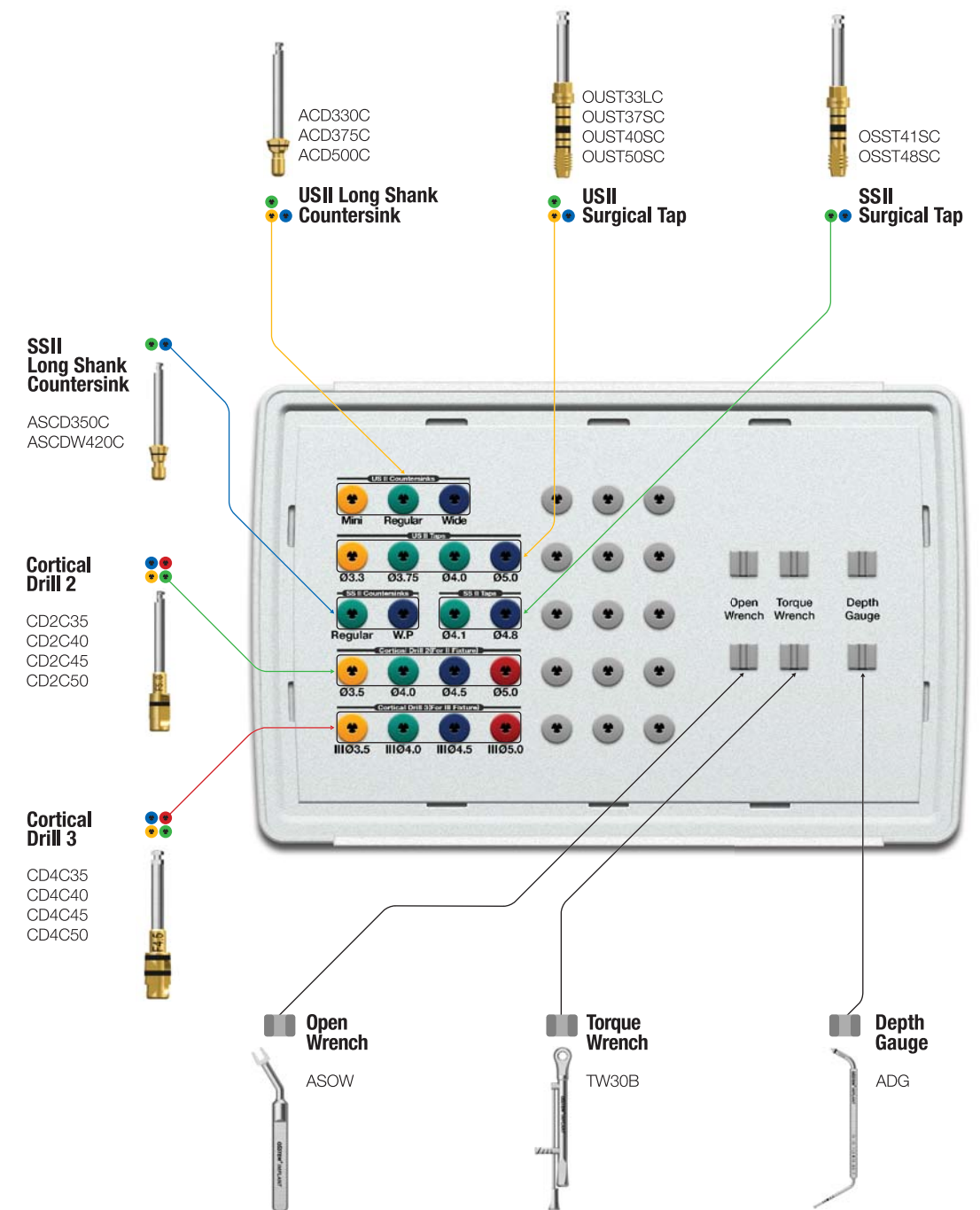
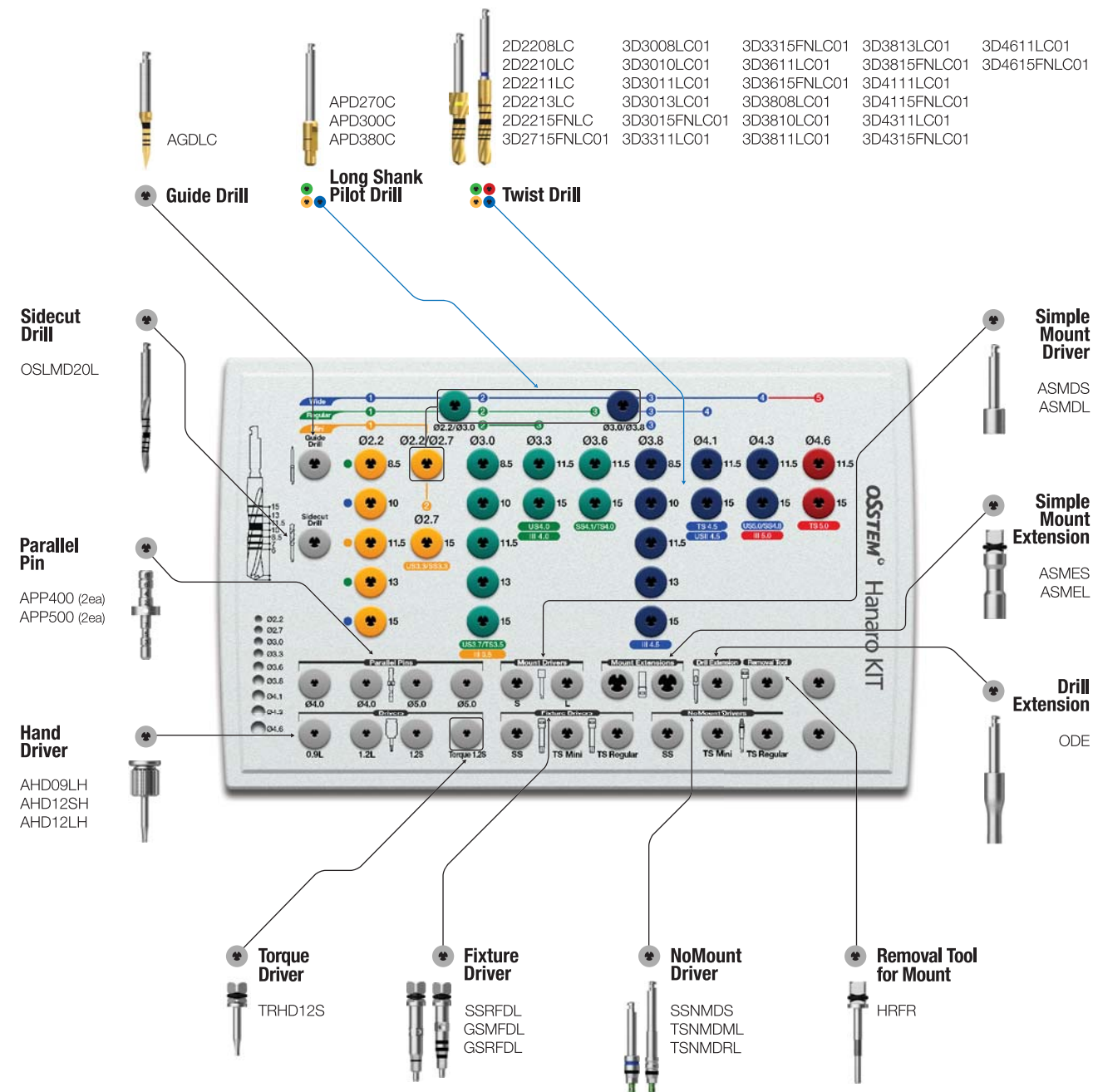

New Hanaro KIT Surgical Instruments

Twist Drill - Stopper Drill

- Long stopper (6mm)
- can be performed without drill extension in posterior surgery
- Color coding of stopper part shows drill length

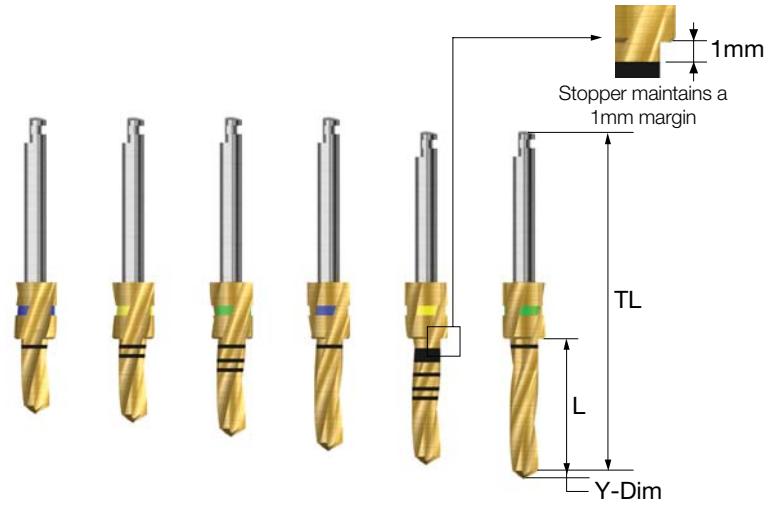

L	TL	D	Ø2.2	Ø3.0	Ø3.3	Ø3.6	Ø3.8	Ø4.1	Ø4.3	Ø4.6
	Y-Dim		0.6	0.9	1.0	1.0	1.0	1.0	1.0	1.0
6	30.5	2D2206LC	3D3006LC	-	-	-	3D3806LC	-	-	-
7	31.5	2D2207LC01	3D3007LC01	-	-	-	3D3807LC01	-	-	-
8.5	33	2D2208LC01	3D3008LC01	-	-	-	3D3808LC01	-	-	-
10	34.5	2D2210LC01	3D3010LC01	-	-	-	3D3810LC01	-	-	-
11.5	34.5	2D2211LC01	3D3011LC01	3D3311LC01	3D3611LC01	3D3811LC01	3D4111LC01	3D4311LC01	3D4611LC01	-
13	36	2D2213LC01	3D3013LC01	-	-	-	3D3813LC01	-	-	-

Twist Drill - Non Stopper Drill

- Used when the accessibility of the stopper drill is low
- Short and long laser marked drills are available

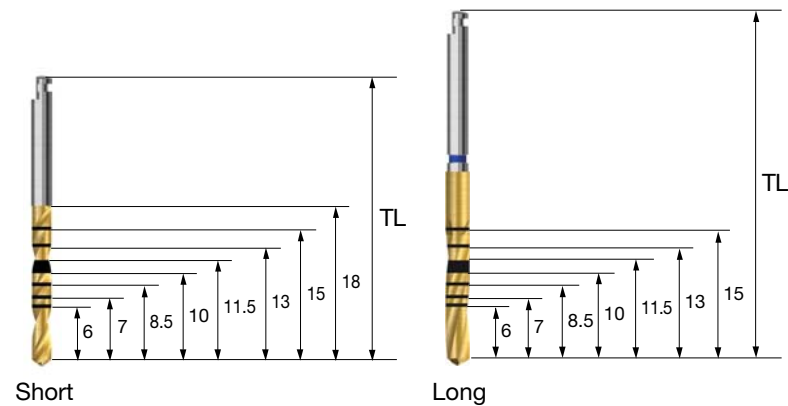

TL	D	Ø1.5	Ø2.0	Ø2.2	Ø2.7	Ø3.0	Ø3.3
33		2D1518FNLC	2D2018FNLC	2D2218FNLC	3D2718FNLC	3D3018FNLC	3D3318FNLC
41		-	-	2D2215FNLC01	3D2715FNLC01	3D3015FNLC01	3D3315FNLC01

TL	D	Ø3.6	Ø3.8	Ø4.1	Ø4.3	Ø4.6
33		3D3618FNLC	3D3818FNLC	3D4118FNLC	3D4318FNLC	3D4618FNLC
41		3D3615FNLC01	3D3815FNLC01	3D4115FNLC01	3D4315FNLC01	3D4615FNLC01

Long Shank Pilot Drill

- Corrects the drilling path
- Maintains the path of the previous drilling sequence

D1 / D2	Ø2.0 / 2.7	Ø2.0 / 3.0	Ø3.0 / 3.8	Ø3.0 / 4.1
	APD270C	APD300C	APD380C	APD410C

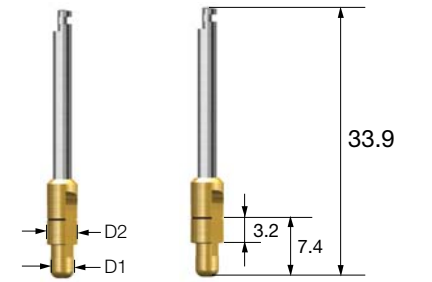

Cortical Drill 2 for TSII, SSII SA

- Trims cortical bone in hard bone cases (for type II)
- Drill specifically for type II fixture's unique diameter
- Recommend drilling until reaching the bottom of the marker
- F = Fixture

F3.5	F4.0	F4.5	F5.0
CD2C35	CD2C40	CD2C45	CD2C50



Cortical Drill 3 for Taper Fixture (TSIII, SSIII, USIII)

- Use after straight drill to expand cortical bone
- In normal to hard bone, used as the final drill
- Drill specifically for type III fixture's unique diameter
- The lower marker is for normal bone, the upper is for hard bone
- Recommend drilling until reaching the bottom of the marker

F3.0	F3.5	F4.0	F4.5	F5.0	F5.5
CD4C30	CD4C35	CD4C40	CD4C45	CD4C50	CD4C55



Countersink for USIII, USII SA, USIII SA (Wide PS, Wide)

- Drill specifically for USIII, USII SA, and USIII SA Wide PS and wide type fixtures
- Recommended drilling speed : 300rpm

USSCS45W

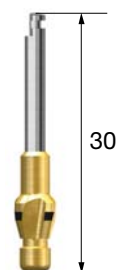

New Hanaro KIT Surgical Instruments

Straight Fixture Tap for TSII, USII, SSII SA

- Tap for straight body fixtures (type II)
- For hard bone, taps osteotomy creating fixture thread shape
- Recommended speed : 25rpm or hand torque
- Recommended tapping until reaching the bottom of the marker
- F = Fixture



F3.5	F4.0	F4.5	F5.0
O2FTS35	O2FTS40	O2FTS45	O2FTS50

Parallel Pin

- Identifies the direction and location of the osteotomy

D	Ø4.0	Ø5.0	Ø6.0	Full Set
	APP400	APP500	APP600	APPS

※ Refer to surgical instruments for other components (106p-)

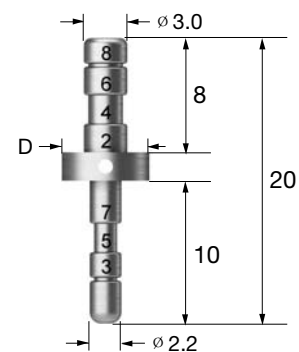

OSSTEM[®]
IMPLANT

Ultra KIT (HULTRK)

Ultra KIT Surgical Instruments

For **Ultra-wide**

Lower panel components

Open Wrench
SPOW



Ratchet Wrench
RCWC

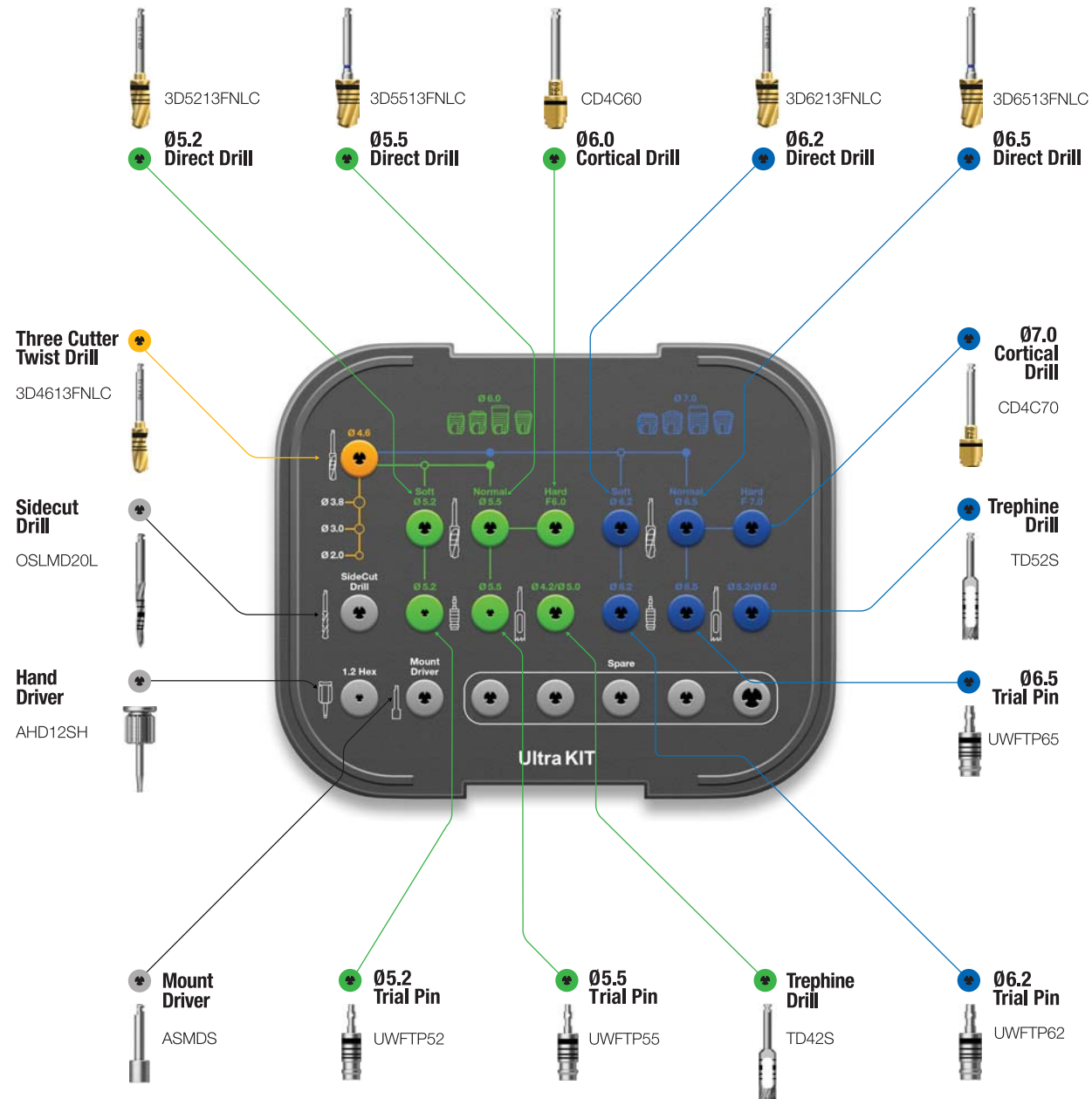

Direct Drill

- Direct drill : two-step drill that functions like a pilot and twist drill
- Final drilling is possible without using pilot drilling
- Increases initial stability in an extraction socket due to the reduced dead space at the apex

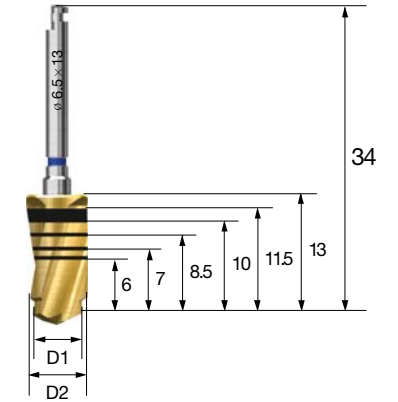

D1 / D2	Ø4.6 / 5.2	Ø4.6 / 5.5	Ø5.5 / 6.2	Ø5.5 / 6.5
	3D5213FNLC	3D5513FNLC	3D6213FNLC	3D6513FNLC

Cortical Drill for Ultra-wide

- Trims cortical bone in hard bone cases (for ultra-wide type fixtures)
- Drill specifically for ultra-wide type fixture's unique diameter
- Recommend drilling until reaching the bottom of the marker
- F = Fixture

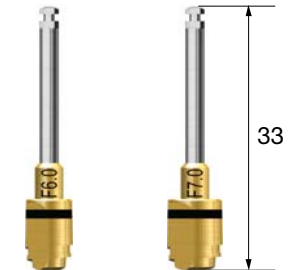

F6.0	F7.0
CD4C60	CD4C70

Trial Pin for Ultra-wide

- Measures the width and depth of a failed implant site
- Measure the drilling depth after using the direct drill as the final drill
- Also serves as a parallel pin

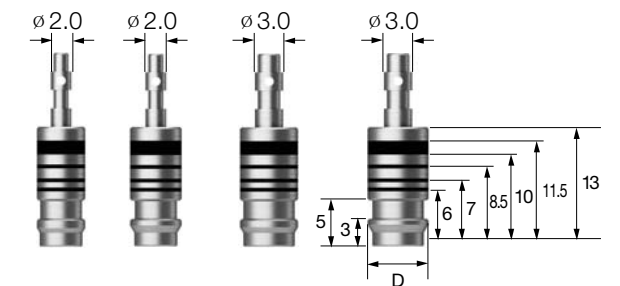

D	Ø5.2	Ø5.5	Ø6.2	Ø6.5
	UWFTP52	UWFTP55	UWFTP62	UWFTP65

※ Refer to surgical instruments for other components (106p~)

090 OSSTEM KIT

091 OSSTEM KIT

Drilling Sequence II Type Straight Drill

TSII | SSII | USII

(Length : 10mm)

Ø3.5mm



Bone Quality	Ø 2.2 Drill	Ø 2.7 Drill	Ø 2.0/3.0 Pilot Drill	Ø 3.0 Drill	F3.5 Cortical Drill	F3.5 Straight Fixture Tap	Ø 3.5 Fixture
Soft	▶	▶					
Normal	▶		▶	▶			Implant Placement
Hard	▶		▶	▶	▶		
Hard (Option)	▶		▶	▶		▶	

Ø5.0mm

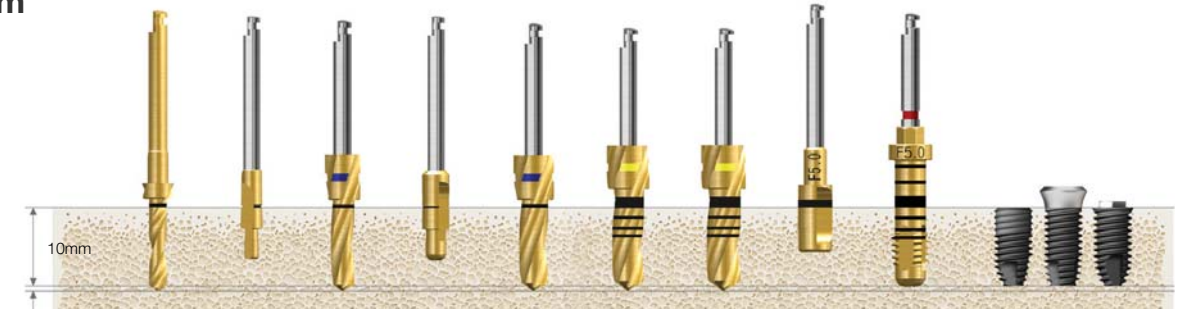

Bone Quality	Ø 2.2 Drill	Ø 2.0/3.0 Pilot Drill	Ø 3.0 Drill	Ø 3.0/3.8 Pilot Drill	Ø 3.8 Drill	Ø 4.3 Drill	Ø 4.6 Drill	F5.0 Cortical Drill	F5.0 Straight Fixture Tap	Ø 5.0 Fixture
Soft	▶	▶	▶	▶	▶	▶				
Normal	▶	▶	▶	▶	▶		▶			Implant Placement
Hard	▶	▶	▶	▶	▶		▶	▶		
Hard (Option)	▶	▶	▶	▶	▶		▶		▶	

Ø4.0mm

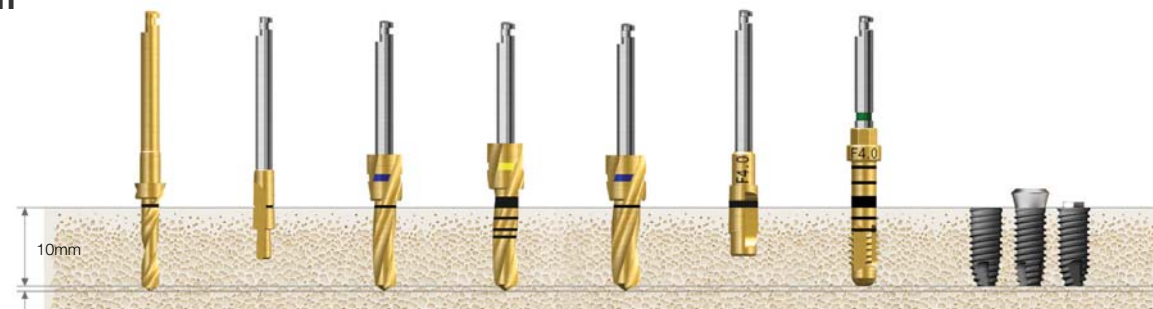

Bone Quality	Ø 2.2 Drill	Ø 2.0/3.0 Pilot Drill	Ø 3.0 Drill	Ø 3.3 Drill	Ø 3.8 Drill	F4.0 Cortical Drill	F4.0 Straight Fixture Tap	Ø 4.0 Fixture
Soft	▶	▶	▶	▶				
Normal	▶	▶	▶		▶			Implant Placement
Hard	▶	▶	▶		▶	▶		
Hard (Option)	▶	▶	▶		▶		▶	

Ø4.5mm

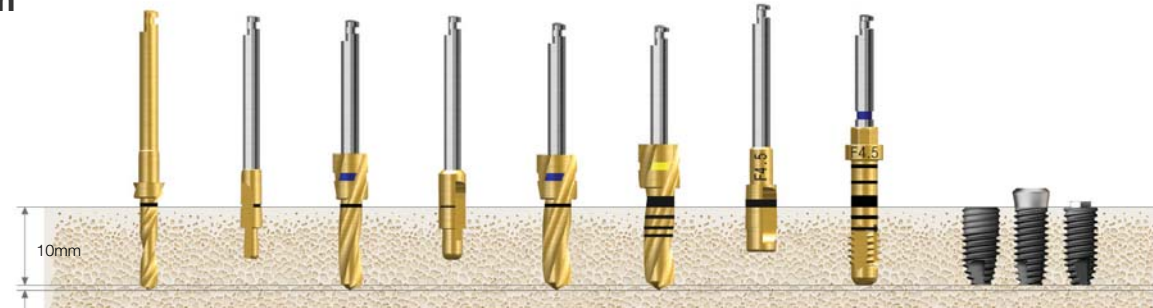

Bone Quality	Ø 2.2 Drill	Ø 2.0/3.0 Pilot Drill	Ø 3.0 Drill	Ø 3.0/3.8 Pilot Drill	Ø 3.8 Drill	Ø 4.1 Drill	F4.5 Cortical Drill	F4.5 Straight Fixture Tap	Ø 4.5 Fixture
Soft	▶	▶	▶	▶	▶				
Normal	▶	▶	▶	▶	▶	▶			Implant Placement
Hard	▶	▶	▶	▶	▶	▶	▶		
Hard (Option)	▶	▶	▶	▶	▶	▶		▶	

Recommended insertion torque ≤40Ncm

TS fixture insertion depth The normal/hard bone is placed 1mm deeper than the bone level, and the soft bone is placed at the bone level to maintain the fixed strength

In hard bone, recommended speed is 25rpm or use of torque wrench with mount extension

Drilling Sequence III Type Straight Drill

TSIII | SSIII | USIII

(Length : 10mm)

Ø3.0mm

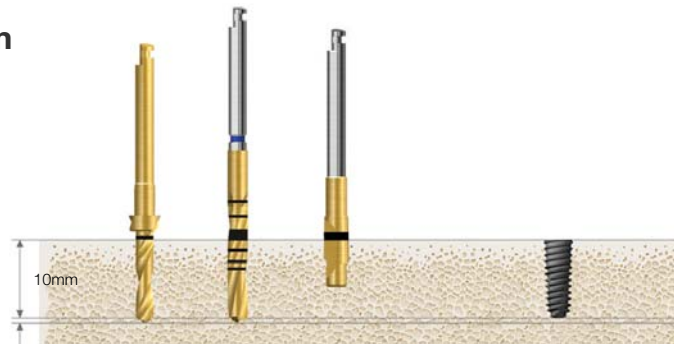

Bone Quality	Ø 2.2 Drill	Ø 2.7 Drill	F3.0 Cortical Drill 2	Ø 3.0 Fixture
Soft	▶			
Normal	▶	▶		Implant Placement
Hard	▶	▶	▶	

Ø3.5mm



Bone Quality	Ø 2.2 Drill	Ø 2.0/3.0 Pilot Drill	Ø 3.0 Drill	F3.5 Cortical Drill 3	F3.5 Cortical Drill 3	Ø 3.5 Fixture
Soft	▶	▶	▶			
Normal	▶	▶	▶	▶		Implant Placement
Hard	▶	▶	▶		▶	

Ø4.0mm



Bone Quality	Ø 2.2 Drill	Ø 2.0/3.0 Pilot Drill	Ø 3.0 Drill	Ø 3.3 Drill	F4.0 Cortical Drill 3	F4.0 Cortical Drill 3	Ø 4.0 Fixture
Soft	▶	▶	▶	▶			
Normal	▶	▶	▶	▶	▶		Implant Placement
Hard	▶	▶	▶	▶		▶	

Recommended insertion torque ≤40Ncm, for the TSIII/SSIII HA : ≤35Ncm (the HA coating can fracture and flake off when placed in hard bone)
 TS fixture insertion depth The normal/hard bone is placed 1mm deeper than the bone level, and the soft bone is placed at the bone level to maintain the fixed strength

Ø4.5mm



Bone Quality	Ø 2.2 Drill	Ø 2.0/3.0 Pilot Drill	Ø 3.0 Drill	Ø 3.0/3.8 Pilot Drill	Ø 3.8 Drill	F4.5 Cortical Drill 3	F4.5 Cortical Drill 3	Ø 4.5 Fixture
Soft	▶	▶	▶	▶	▶			
Normal	▶	▶	▶	▶	▶	▶		Implant Placement
Hard	▶	▶	▶	▶	▶		▶	

Ø5.0mm



Bone Quality	Ø 2.2 Drill	Ø 2.0/3.0 Pilot Drill	Ø 3.0 Drill	Ø 3.0/3.8 Pilot Drill	Ø 3.8 Drill	Ø 4.3 Drill	F5.0 Cortical Drill 3	F5.0 Cortical Drill 3	Ø 5.0 Fixture
Soft	▶	▶	▶	▶	▶				
Normal	▶	▶	▶	▶	▶	▶	▶		Implant Placement
Hard	▶	▶	▶	▶	▶	▶		▶	

Ø5.5mm



Bone Quality	Ø 2.2 Drill	Ø 2.0/3.0 Pilot Drill	Ø 3.0 Drill	Ø 3.0/3.8 Pilot Drill	Ø 3.8 Drill	Ø 4.6 Drill	F5.5 Cortical Drill 3	F5.5 Cortical Drill 3	Ø 5.5 Fixture
Soft	▶	▶	▶	▶	▶	▶			
Normal	▶	▶	▶	▶	▶	▶	▶		Implant Placement
Hard	▶	▶	▶	▶	▶	▶		▶	

Drilling Sequence IV Type Straight Drill

TSIV | USIV

(Length : 10mm)

Ø4.0mm

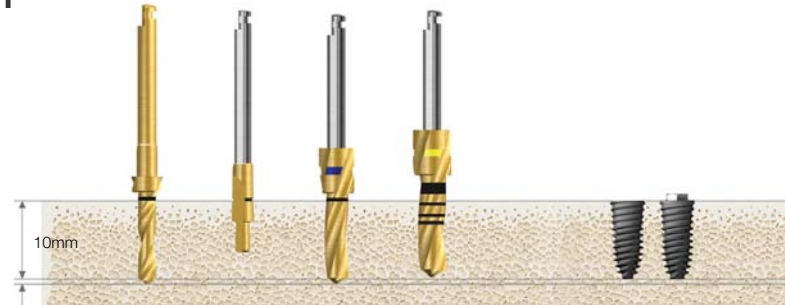

Bone Quality	Ø 2.2 Drill	Ø 2.0/3.0 Pilot Drill	Ø 3.0 Drill	Ø 3.0 Drill (Half)	Ø 4.0 Fixture
D4	▶				Implant Placement
Soft	▶	▶	▶	▶	

Ø4.5mm



Bone Quality	Ø 2.2 Drill	Ø 2.0/3.0 Pilot Drill	Ø 3.0 Drill	Ø 3.0/3.8 Pilot Drill	Ø 3.8 Drill	Ø 4.1 Drill (Half)	Ø 4.5 Fixture
D4			▶				Implant Placement
Soft	▶	▶	▶	▶	▶	▶	

Ø5.0mm



Bone Quality	Ø 2.2 Drill	Ø 2.0/3.0 Pilot Drill	Ø 3.0 Drill	Ø 3.0/3.8 Pilot Drill	Ø 3.8 Drill	Ø 4.6 Drill (Half)	Ø 5.0 Fixture
D4			▶				Implant Placement
Soft	▶	▶	▶	▶	▶	▶	

Drilling Sequence Ultra-wide Straight Drill

TSII Ultra-wide | SSII Ultra-wide | USII Ultra-wide

(Length : 10mm)

Ø6.0mm

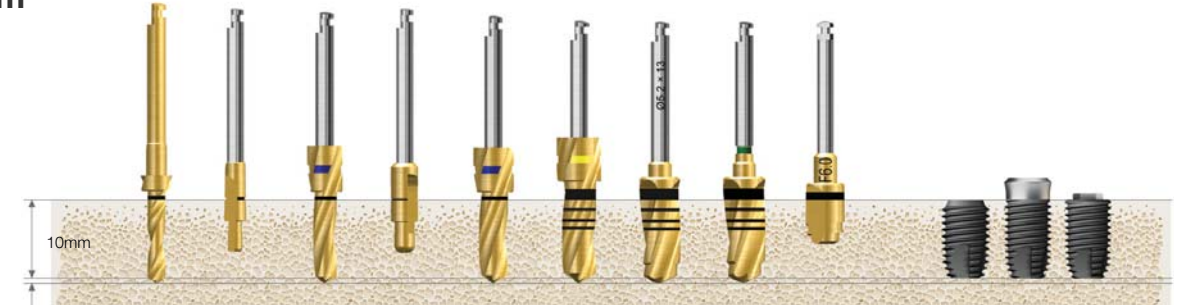

Bone Quality	Ø 2.2 Drill	Ø 2.0/3.0 Pilot Drill	Ø 3.0 Drill	Ø 3.0/3.8 Pilot Drill	Ø 3.8 Drill	Ø 4.6 Drill	Ø 5.2 Direct Drill	Ø 5.5 Direct Drill	F6.0 Cortical Drill	Ø 6.0 Fixture
Soft	▶	▶	▶	▶	▶	▶	▶			Implant Placement
Normal	▶	▶	▶	▶	▶	▶		▶		
Hard	▶	▶	▶	▶	▶	▶		▶	▶	

Ø7.0mm



Bone Quality	Ø 2.2 Drill	Ø 2.0/3.0 Pilot Drill	Ø 3.0 Drill	Ø 3.0/3.8 Pilot Drill	Ø 3.8 Drill	Ø 4.6 Drill	Ø 5.5 Direct Drill	Ø 6.2 Direct Drill	Ø 6.5 Direct Drill	F7.0 Cortical Drill	Ø 7.0 Fixture
Soft	▶	▶	▶	▶	▶	▶	▶	▶			Implant Placement
Normal	▶	▶	▶	▶	▶	▶	▶		▶		
Hard	▶	▶	▶	▶	▶	▶	▶		▶	▶	

Recommended insertion torque ≤40Ncm

TSIV/USIV system is designed specifically for the maxillary sinus and soft bone. It is not recommended in the normal bone or more recommend reducing the insertion speed to 15rpm or lower, due to the TSIV/USIV aggressive threads

Drilling Sequence **Ultra-wide Straight Drill**

TSII Ultra-wide | **SSII Ultra-wide** | **USII Ultra-wide**

(Length : 10mm)

Ø6.0mm

Drilling sequence with trephine in the healed mature bone

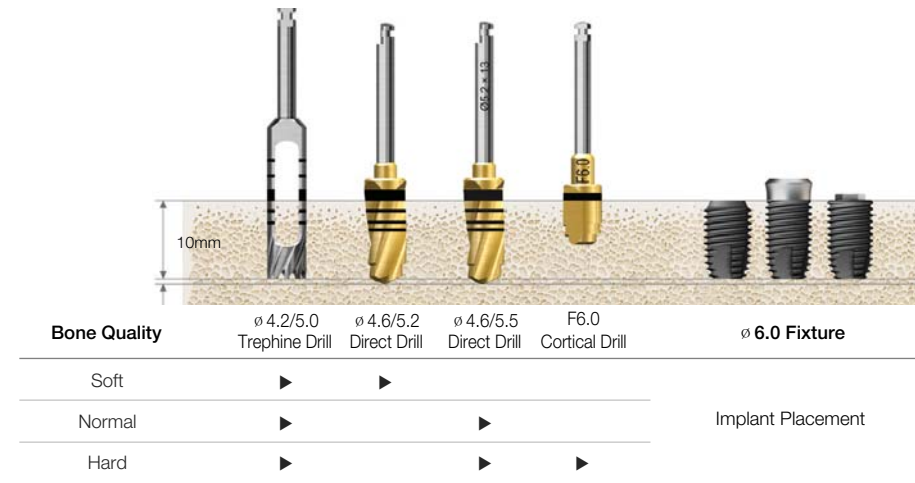

Immediate placement at the extraction socket

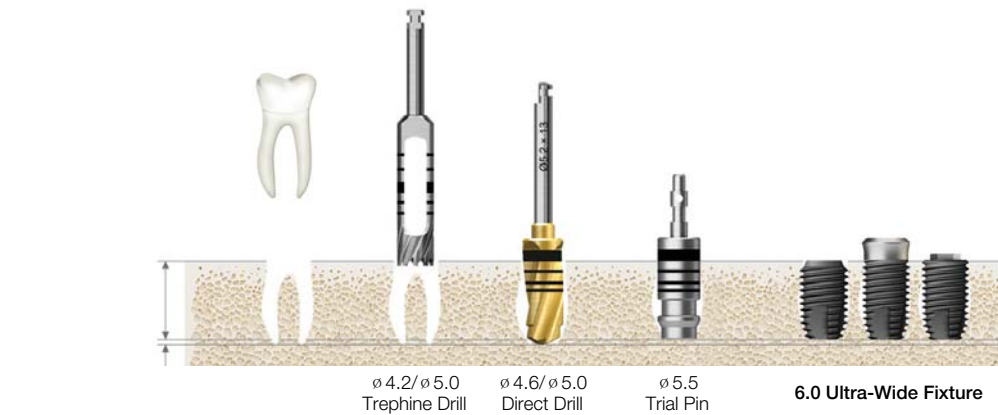

Immediate replacement of the failed implant

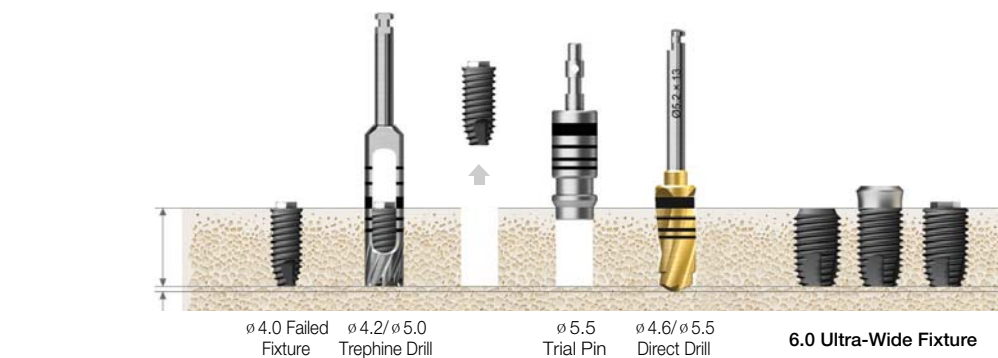

Drilling Sequence **Ultra-wide Straight Drill**

TSIII Ultra-wide | **SSIII Ultra-wide** | **USIII Ultra-wide**

(Length : 10mm)

Ø6.0mm

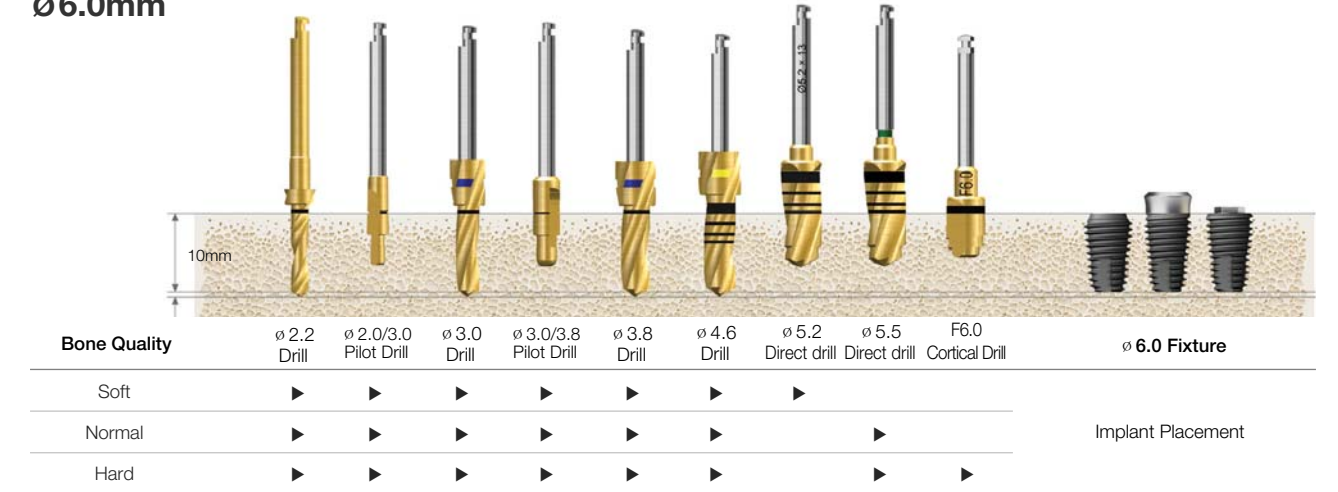

Ø7.0mm



Recommended insertion torque ≤ 40Ncm

TS fixture insertion depth The normal/hard bone is placed 1mm deeper than the bone level, and the soft bone is placed at the bone level to maintain the fixed strength

Drilling Sequence **Ultra-wide Straight Drill**
TSIV Ultra-wide | **USIV Ultra-wide**
 (Length : 10mm)

Ø6.0mm

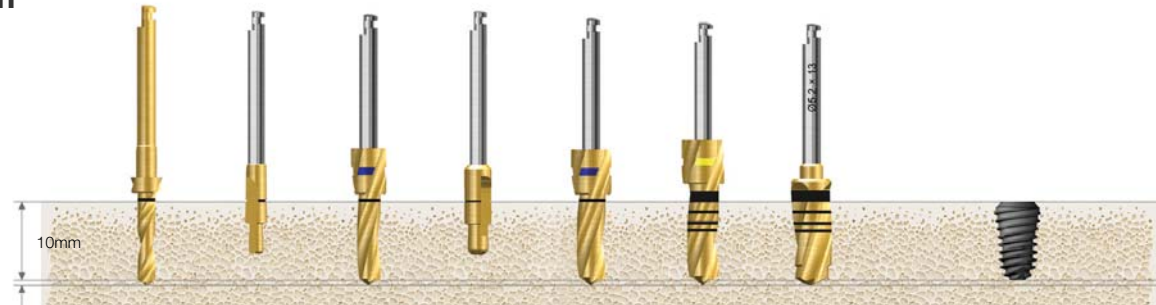

Bone Quality	Ø 2.2 Drill	Ø 2.0/3.0 Pilot Drill	Ø 3.0 Drill	Ø 3.0/3.8 Pilot Drill	Ø 3.8 Drill	Ø 4.6 Drill	Ø 5.2 Direct Drill	Ø 6.0 Fixture
D4	▶	▶			▶			Implant Placement
Soft	▶	▶	▶	▶	▶	▶	▶	

Ø7.0mm



Bone Quality	Ø 2.2 Drill	Ø 2.0/3.0 Pilot Drill	Ø 3.0 Drill	Ø 3.0/3.8 Pilot Drill	Ø 3.8 Drill	Ø 4.6 Drill	Ø 5.5 Direct Drill	Ø 6.2 Direct Drill	Ø 7.0 Fixture
D4	▶	▶			▶	▶			Implant Placement
Soft	▶	▶	▶	▶	▶	▶	▶	▶	



485 KIT (O485K)

For **TSIII** **SSIII** **USIII**

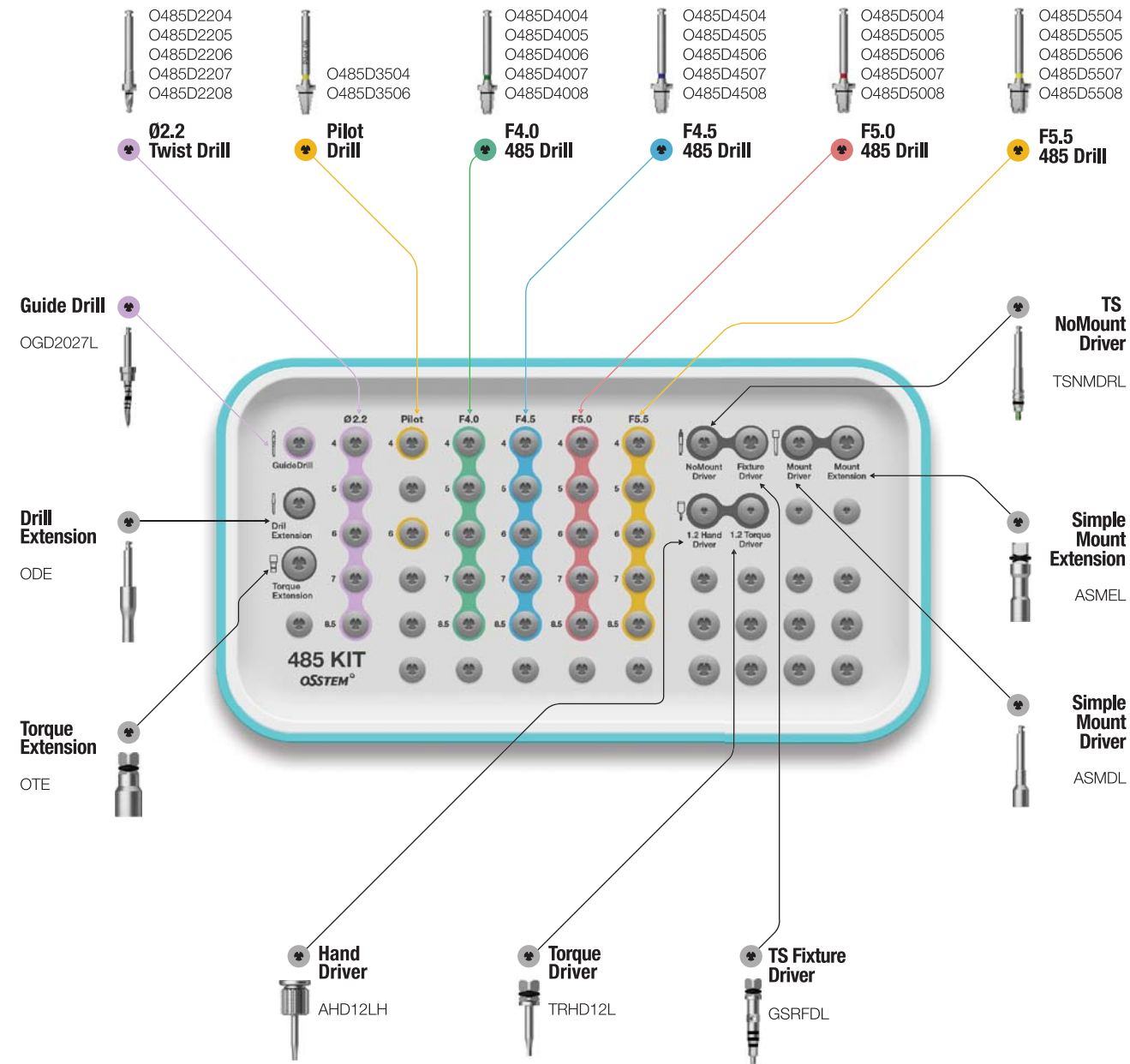

485 KIT Surgical Instruments

485 Drill

- Drill for short implant placement in alveolar bone lacking vertical height
- 2.2 drill : straight drill
- In addition, the drill tip blade is a CAS drill shape, the side blade is a taper drill shape
- Stopper drill with 1mm extra
- Recommended speed : 800~1,200rpm

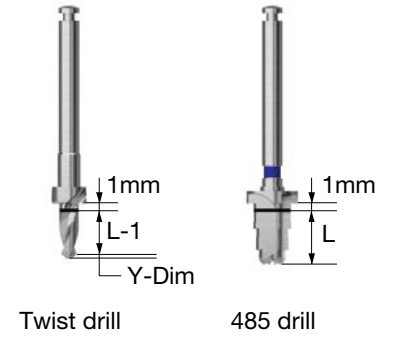

L \ Type	Ø2.2	Pilot	F4.0	F4.5	F5.0	F5.5
4.0	O485D2204	O485D3504	O485D4004	O485D4504	O485D5004	O485D5504
5.0	O485D2205	-	O485D4005	O485D4505	O485D5005	O485D5505
6.0	O485D2206	O485D3506	O485D4006	O485D4506	O485D5006	O485D5506
7.0	O485D2207	-	O485D4007	O485D4507	O485D5007	O485D5507
8.5	O485D2208	-	O485D4008	O485D4508	O485D5008	O485D5508

※ Refer to surgical instruments for other components (106p-)

Drilling Sequence 485 Drill

TSIII | SSIII | USIII

(Length : 7mm)

Ø4.0mm

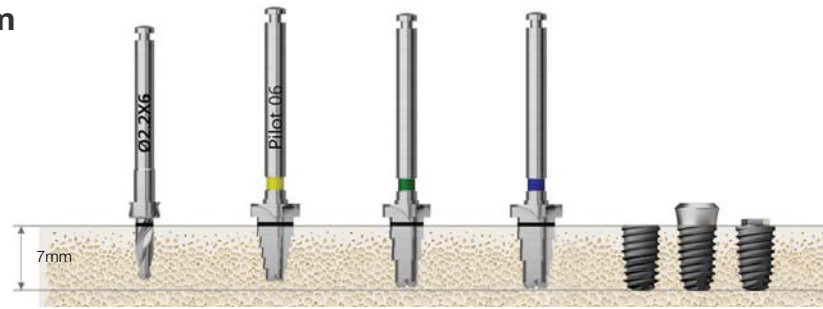

Bone Quality	Ø 2.2 Drill	Pilot Drill	F4.0 485 Drill	F4.5 485 Drill	Ø 4.0 Fixture
Normal	▶	▶	▶		Implant Placement
Hard	▶	▶		▶	

Ø4.5mm

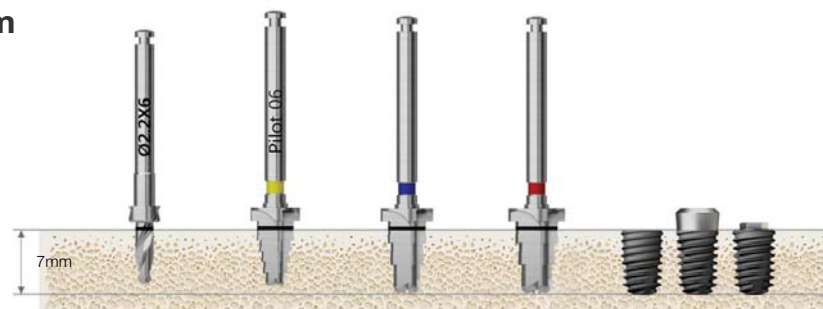

Bone Quality	Ø 2.2 Drill	Pilot Drill	F4.5 485 Drill	F5.0 485 Drill	Ø 4.5 Fixture
Normal	▶	▶	▶		Implant Placement
Hard	▶	▶		▶	

Ø5.0mm

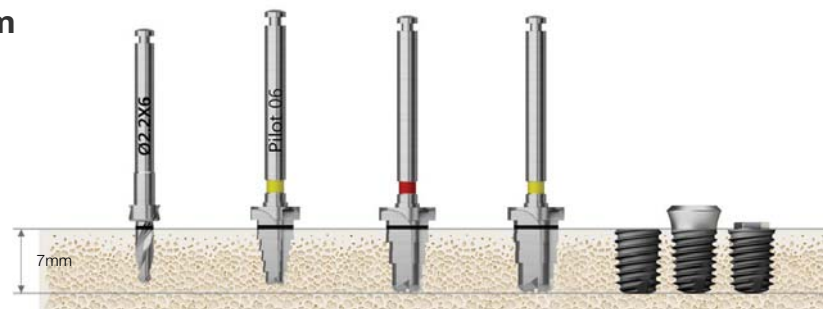

Bone Quality	Ø 2.2 Drill	Pilot Drill	F5.0 485 Drill	F5.5 485 Drill	Ø 5.0 Fixture
Normal	▶	▶	▶		Implant Placement
Hard	▶	▶		▶	

OSSTEM[®]
IMPLANT

Surgical Instruments

123 Guide Drill

- Used to create an hole in the bone to facilitate initial drilling
- Easy drill depth control by selecting the appropriate drill stopper
- 122 taper KIT single Item (excluded from taper KIT)

D	Ø2.0
OGD2027L	

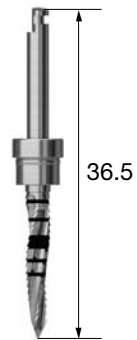

Lance Drill - Guide Drill

- Used to create an hole in the bone to facilitate initial drilling
- Bone density can be determined by drilling
- Taper KIT single Item (excluded from 122 taper KIT)

L	Short	Long
	AGDSC	AGDLC

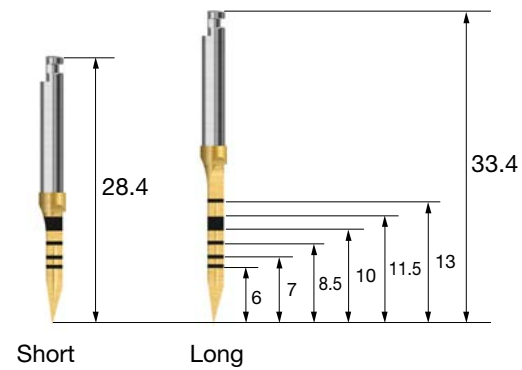

Sidecut Drill

- Capable of side cutting using the drill body's cutter blades
- For trimming the ridge of an extraction socket
- Facilitating site preparation of an extraction socket
- Taper KIT single Item (excluded from 122 taper KIT)

L \ D1 / D2	Ø1.5 / 2.0	Ø2.0 / 2.5	Ø3.0 / 3.5
13	OSLMDS	OSLMD20S	-
16.5	-	-	OSLMD30L
20	OSLMDL	OSLMD20L	-

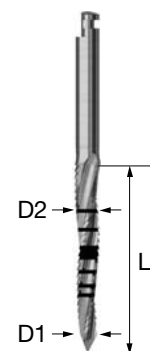

Drill Extension

- Drill and other handpiece tool' extension (drill 14.9/16.9mm extension)
- In case of improper fastening, excessive force may cause bending or breakage
- Taper KIT, straight KIT common components (ODE)

L (연장)	14.9	16.9
	HDE	ODE



NoMount Driver for TS

- Engine driver which is connected directly with the fixture for placement
- C = Connection

L \ C	Mini	Regular
Short	TSNMDMS	TSNMDRS
Long	TSNMDML	TSNMDRL
Ex.Long	TSNMDME	TSNMDRE

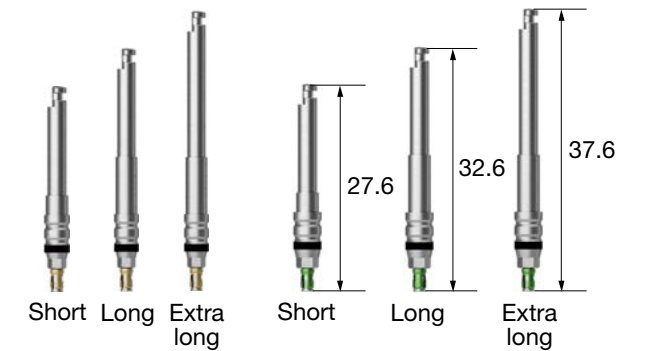

NoMount Driver for SS

- Engine driver which is connected directly with the fixture for placement
- C = Connection

L \ C	Regular / Wide
Short	SSNMDS
Long	SSNMDL
Ex.Long	SSNMDE

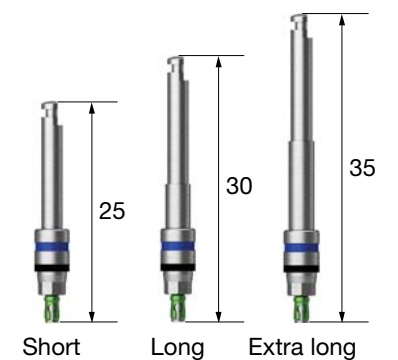

Surgical Instruments

NoMount Driver for US

- Engine driver which is connected directly with the fixture for placement
- C = Connection

L \ C	Mini	Regular	Wide
Short	USNMD35MS	USNMD41RS	USNMD51WS
Long	USNMD35ML	USNMD41RL	USNMD51WL

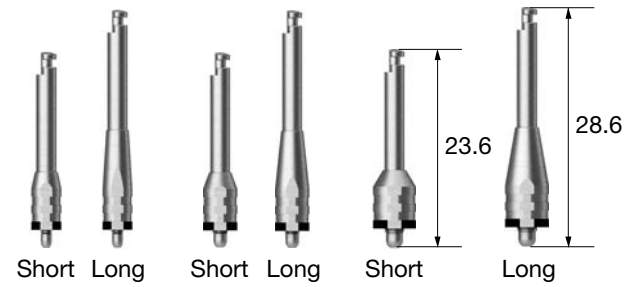

Fixture Driver for TS

- Connects directly to the fixture for final adjustments to the implant's depth. Also removes the implant.
- C = Connection

L \ C	Mini	Regular
Short	GSMFDS	GSRFDS
Long	GSMFDL	GSRFDL
Ex.Long	GSMFDE	GSRFDE

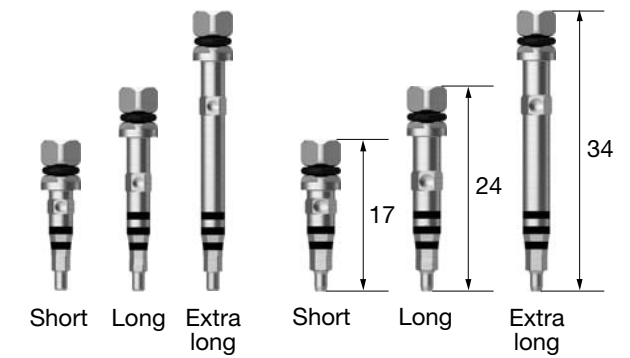

NoMount Torque Driver for TS

- Torque wrench driver connects directly with the fixture (without a mount) for placement
- Make sure fixture and driver is securely connected; loose connection may cause fixture fracture
- It can not be removed when a fracture occurs
- C = Connection

L \ C	Mini	Regular
Short	GSNMT32S	GSNMT35S
Long	GSNMT32L	GSNMT35L
Ex.Long	GSNMT32E	GSNMT35E

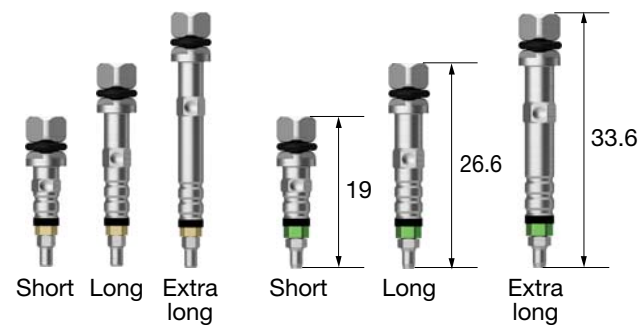

Fixture Driver for SS

- Connects directly to the fixture for final adjustments to the implant's depth. Also removes the implant.
- C = Connection

L \ C	Regular/Wide
Short	SSRFDS
Long	SSRFDL
Ex.Long	SSRFDE

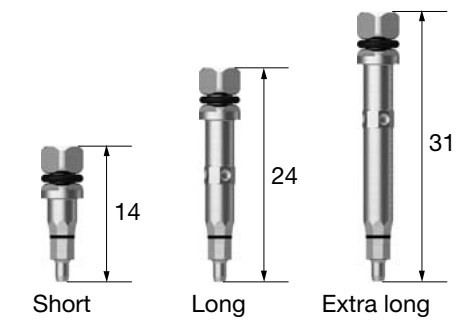

NoMount Torque Driver for SS

- Torque wrench driver connects directly with the fixture (without a mount) for placement
- Make sure fixture and driver is securely connected; loose connection may cause fixture fracture
- It can not be removed when a fracture occurs
- C = Connection

L \ C	Regular/Wide
Short	SSNMT39S
Long	SSNMT39L

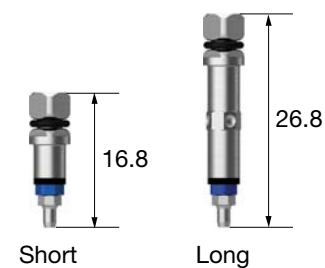

Fixture Driver for US

- Connects directly to the fixture for final adjustments to the implant's depth. Also removes the implant.
- C = Connection

C	Mini	Regular	Wide
	USMFDL	USRFDL	USWFDL



Surgical Instruments

Torque Extension

- Extends the length of an instrument by 10mm

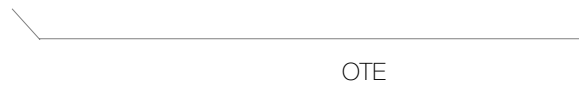

OTE



Simple Mount Driver

- Connects to mounted fixtures for placement

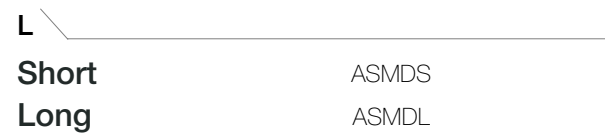

Short ASMDS
Long ASMDL

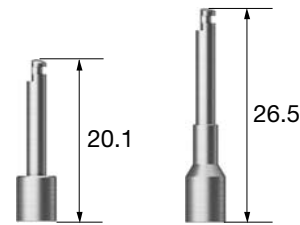

Simple Mount Extension

- Extends the length of the simple mount driver and it is used with wrench

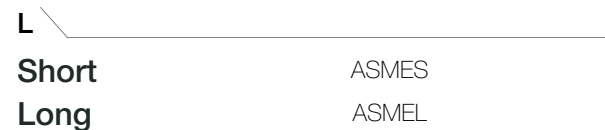

Short ASMES
Long ASMEL

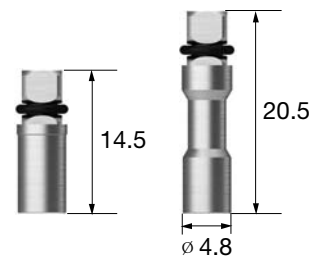

Simple Open Wrench

- Disengages the simple mount when bone quality is poor
- Easy insertion into the mouth with a neck angle of 30°



ASOW



Removal Tool for Fixture Mount

- Removes the mount screw when a fixture and mount become wedged
- Connects to a driver handle and a torque wrench
- Insert vertically, and rotate it clock-wise to remove the mount
- App = Application

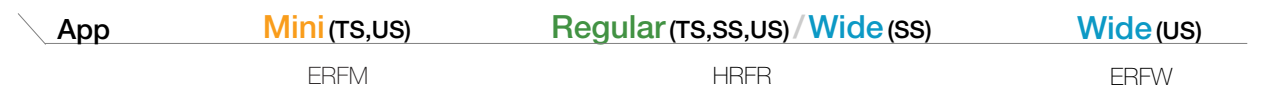

Depth Gauge

- Measures drilling depth (7~15mm)
- Common components of 122 taper & taper KIT



OSDG

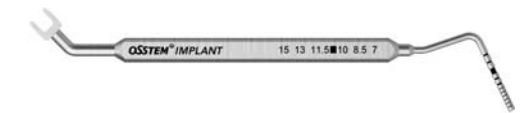

Positioning Guide

- Sets the drilling interval for fixture insertion
- Keep inserting after initial drilling
- Packing unit : the components and packages

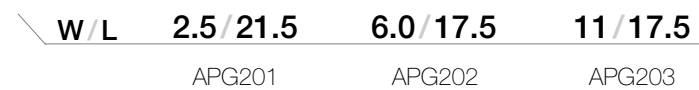

APG201

APG202

APG203

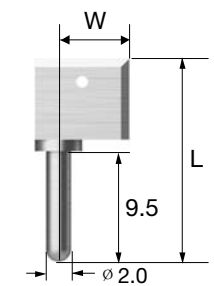

Tissue Height Gauge for TS

- Connects to the TS fixture to measure the height of the gingiva in relation to the fixture



HGTHGS



Surgical Instruments

Ratchet Wrench

- It prevents wrench from backdriving
- Excessive torquing may cause damage to the bone or the inside of a fixture



CITQW-1185A

L-Wrench

- 1.2 hex driver for hard to reach areas like narrow intermaxillary areas
- Torque indication : when the wrench starts to bend (around 10°), it is possible to apply 5~8Ncm of torque

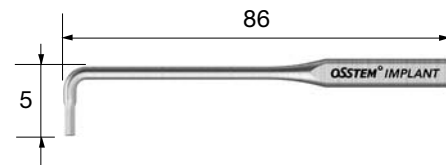

LWC

Torque Wrench - Spring Type

- Applies a precise amount of torque (10/20/30Ncm) to the screw and abutment
- The neck of the torque wrench will bend when the exact amount of torque has been delivered
- Do not continue to torque after the neck has bent. Excessive force may cause screw fracture etc.



TW30

Torque Wrench - Bar Type

- Adjusts the implant depth, and tightens abutments, screws, etc.
- Pull the bar back until reaching the desired torque value



TW30B

Torque Wrench Set

- Bi-directional torque wrench (a torque connector is included)
- Without separating the connector, rotate the handle to apply torque, either in a forward or a backward direction
- Compatible with osstem's machine driver connector
- Pull the bar back until reaching the desired torque value
- Packing unit : changeable torque wrench + torque connector



MX30

Tissue Punch

- For flapless surgery
 - Measures the height of gingiva, marked at 2mm increments
 - Packing unit : tissue punch + guide pin
- ※ Recommend using a tissue punch smaller than the healing abutment by 0.7 to 1.5mm

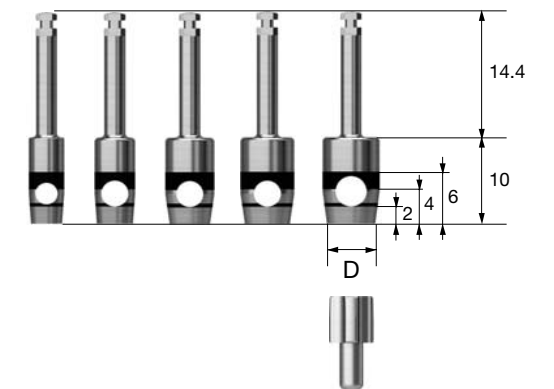

D	Ø3.3	Ø3.8	Ø4.3	Ø4.8	Ø5.3
	OSTP33	OSTP38	OSTP43	OSTP48	OSTP53
TS	Ø 4.0/4.5	Ø 4.5/5.0	Ø 5.0	Ø 6.0	Ø 6.0
SS	-	Ø 4.8	-	Ø 6.0	Ø 6.0
US	Ø 4.0	Ø 5.0	Ø 5.0	Ø 6.0	Ø 6.0

Application healing abutment standard

Surgical Instruments

TS Bone Profiler

- Trims the bone surrounding a fixture for one stage and two stage procedures
- Connect the guide screw to the fixture in order to center the profiler. Make sure to compensate for the healing abutment.
- Guide screw protects the fixture's platform from damage
- Packing unit : bone profiler + guide screw
- C = Connection

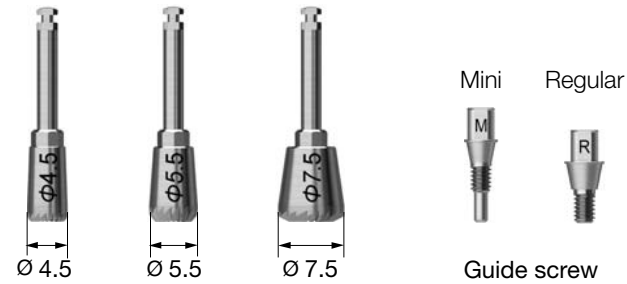

C \ D (Healing Abutment)	Ø4.5	Ø5.5	Ø6.5 / 7.5
Mini / Regular	GSBP45	GSBP55	GSBP75
	Mini + Regular guide screw	Mini + Regular guide screw	Regular guide screw

US Bone Profiler

- Trims the bone surrounding a fixture and cover screw after a two stage procedure
- Remove cover screw, connect the guide screw to the fixture in order to center the profiler. Make sure to compensate for the healing abutment.
- Guide screw protects the fixture's hex from damage
- Packing unit : bone profiler + guide screw
- P = Platform



D \ P	Mini	Regular	Wide	T-type
Ø4.0	ABPM400C	-	-	-
Ø5.0	ABPM500C	ABPR500C	-	-
Ø6.0	-	ABPR600C	ABPW600C	TBPW600C
Ø7.0	-	-	ABPW700C	-

Trephine Drill

- Harvests bone or removes a failed fixture
- Removes septal bone
- Also serves as the initial drill for ultra-wide fixture

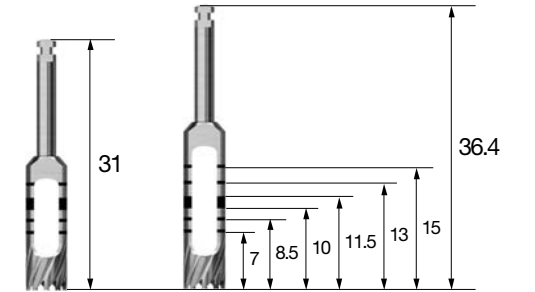

L \ D (Inner / Outer)	3.7 / 4.5	4.2 / 5.0	4.7 / 5.5	5.2 / 6.0	5.7 / 6.5	6.2 / 7.0
Short	TD37S	TD42S	TD47S	TD52S	TD57S	TD62S
Long	TD37	TD42	TD47	TD52	TD57	TD62

Machine Driver Handle

- Manual handle for engine type surgical tools



OMDH

Bone Mill

- Generates particulate bone with harvested autogenous bone

ABM

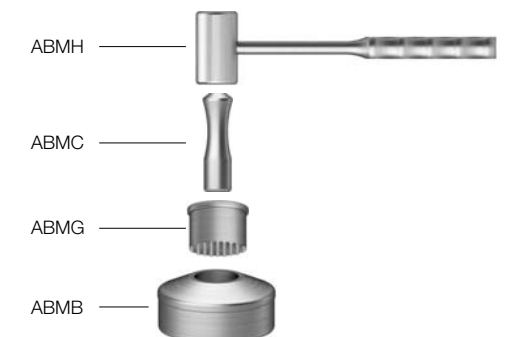

Surgical Instruments

Anterior Hand Driver for Implant

- Manually torque implants in the anterior area
- Connect to a NoMount torque driver or a fixture driver
- Excessive torquing may cause damage to the fixture or driver



AHDI

Torque Handle

- Connect with a contra-angle hand piece (handpiece gear ratio to 1:1)
- Connects healing abutments, cover screws, abutment screws, orthodontic screws, etc. (note : after connecting the part, make sure that it is tightened with a torque wrench)
- Excessive torquing may cause damage to the screw fracture or hand piece



TQHD

OSSTEM[®]
IMPLANT

Prosthetic Simple KIT (OPSK)

Prosthetic KIT (OPK)

Top panel components

Torque Wrench
TW30B

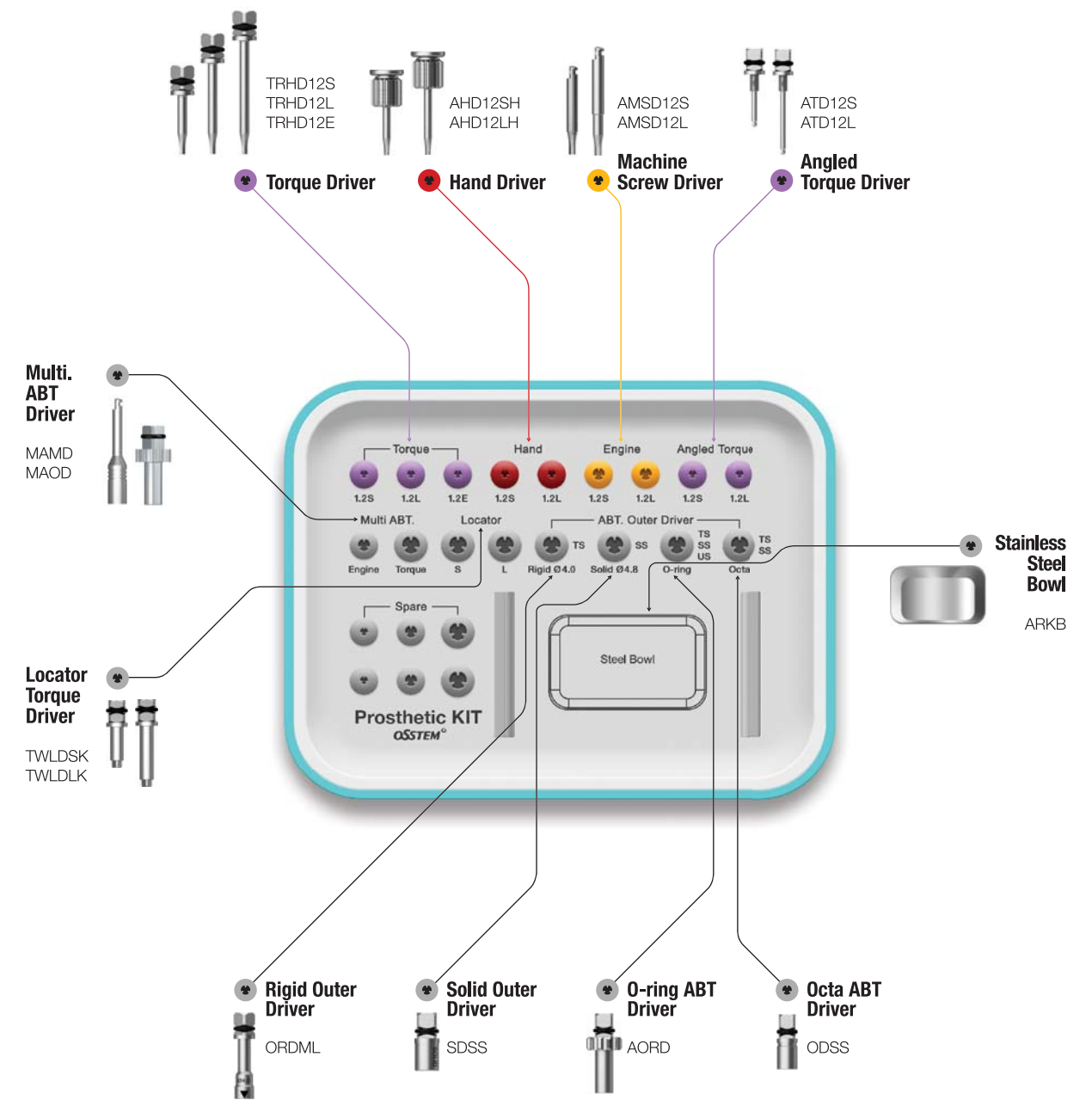
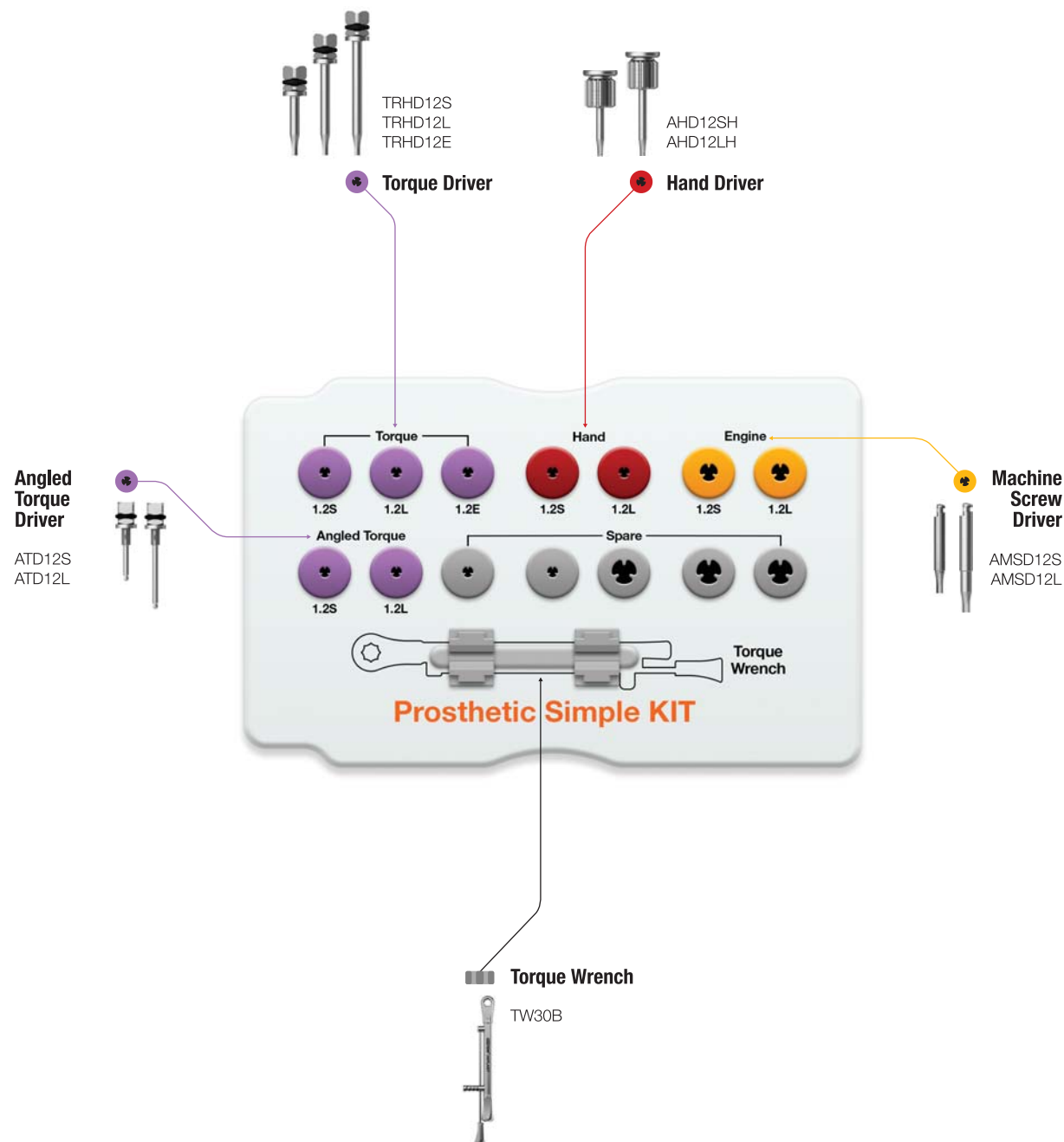

Prosthetic KIT Surgical Instruments

Hand Driver

- Manual driver
- Tip holding function (except internal hex type)
- Internal hex type length : 11

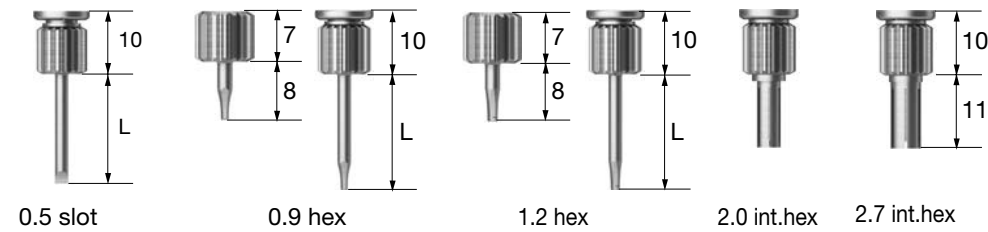

L \ Type	0.5 Slot	0.9 Hex	1.2 Hex	2.0 Int.Hex	2.7 Int.Hex
Ex.Short (8)	-	AHD09MSH	AHD12MSH	-	-
Short (13)	ASD05SH	AHD09SH	AHD12SH	IHD20H	IHD27H
Middle (15)	-	-	AHD12MH	-	-
Long (18)	ASD05LH	AHD09LH	AHD12LH	-	-
Ex.Long (25)	-	-	AHD12EH	-	-

Torque Driver

- Driver for torque wrench
- Tip holding function
- Recommended use (excessive torque causes fracture)
- Possible to generate fracture even at low torque when it is applied after incomplete fastening
- When torque is applied, it should be vertically erected and torque is requested
- If tip is bent for long period of use or over torque, be sure to replace it

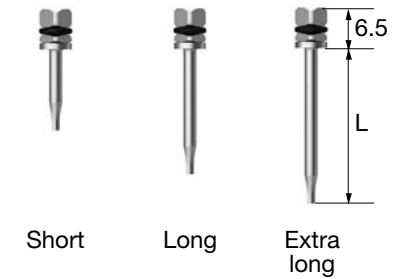

L \ Type	0.5 Slot	0.9 Hex	1.2 Hex	2.0 Int.Hex	2.7 Int.Hex
Ex.Short (8)	-	-	TRHD12MS	-	-
Short (13)	TRSD05S	TRHD09S	TRHD12S	TIHD20S	-
Middle (15)	-	-	TRHD12M	-	-
Long (20)	TRSD05L	TRHD09L	TRHD12L	TIHD20L	TIHD27
Ex.Long (25)	TRSD05E	-	TRHD12E	-	-

Machine Screw Driver

- Engine driver
- Tip holding function (except internal hex type)
- Internal hex type length : 8

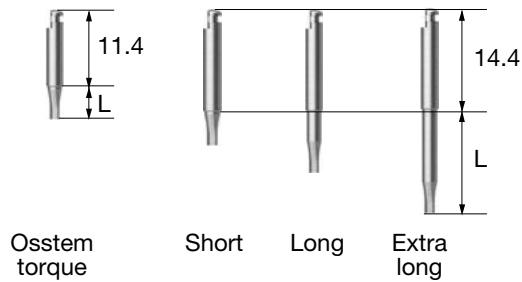

L \ Type	0.5 Slot	0.9 Hex	1.2 Hex	2.0 Int.Hex	2.7 Int.Hex
Osstem Torque (5)	-	-	OTH12S	-	-
Short (5.6)	AMSD05S	AMSD09S	AMSD12S	-	-
Long (11.6)	AMSD05L	AMSD09L	AMSD12L	EIHD20	EIHD27
Ex.Long (17.6)	-	-	AMSD12E	-	-

Application

Driver Applied Products
(hand, machine screw, torque drier common)

Cover screw (US mini)	Healing abutment, UCLA, Cemented abutment screw, Mount screw	Esthetic abutment screw regular, Esthetic-low abutment screw, standard	Wide esthetic-low abutment screw
-----------------------	--	--	----------------------------------

Angled Torque Driver

- Driver for torque wrench
- No holding function
- Recommended tightening torque: 30Ncm (excessive torque causes fracture)
- Do not remove tube to prevent fragmentation when broken
- Recommended use : 10 times
- Set : 3ea

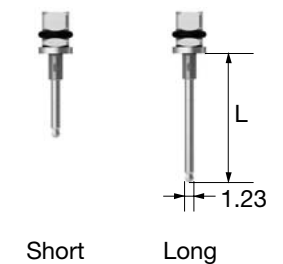

L \ Type	1.2 Hex	1.2 Hex (Set)
Short (13)	ATD12S	ATD12S3S
Long (20)	ATD12L	ATD12L3S

Repair Torque Driver

- Reduced diameter compared to torque driver ($\varnothing 2.1 \rightarrow 1.6$)
- The diameter of the crown hole can be minimized during prosthetic repair or SCRP procedures

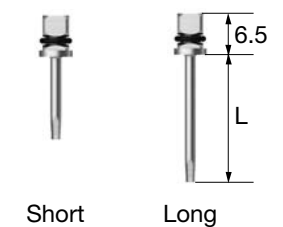

L \ Type	1.2 Hex
Short (13)	TRHD12SR
Long (20)	TRHD12LR

Solid Abutment Driver

- Driver for solid abutment driver
- Insert the groove of the solid abutment into the driver triangle display and apply torque
- Recommended torque : 30Ncm

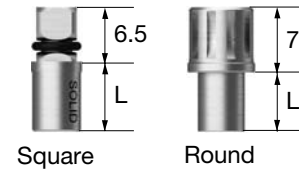

Excellent Solid Abutment Driver

- Driver for excellent solid abutment
- Insert the groove of the excellent solid abutment into the driver triangle display and apply torque
- Recommended torque : 30Ncm

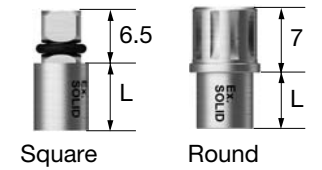

Regular

L \ Type	Square	Round
Short (6)	SDSS	SDRS
Long (12)	SDSL	SDRL

Wide

L \ Type	Square
Short (10)	SD60S

Regular

L \ Type	Square	Round
Short (6)	ESDSS	ESDRS
Long (12)	ESDSL	ESDRL

Wide

L \ Type	Square
Short (10)	ESD60S

O-ring Abutment Driver

- Driver for o-ring abutment

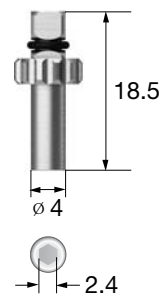

Rigid Outer Driver

- Driver for rigid abutment
- Recommended torque : 30Ncm

L \ D (Abutment)	Ø4.0	Ø4.5	Ø5.0	Ø6.0
Short (16.5)	ORDMS	ORD45S	ORDRS	ORDWS
Long (21.5)	ORDML	ORD45L	ORDRL	ORDWL



Octa Abutment Driver

- Driver for octa abutment
- Recommended torque : 30Ncm

L \ Type	Square	Round
Short	ODSS	ODRS
Long	ODSL	ODRL

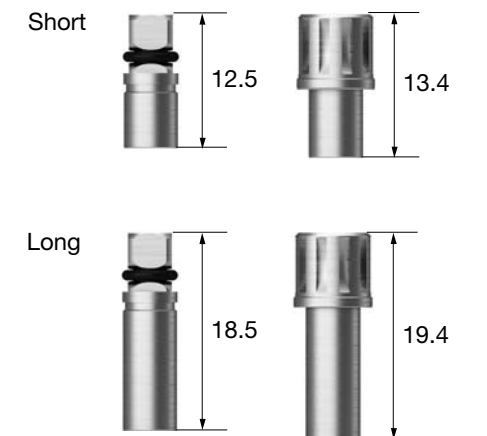

Multi Abutment Machine Driver

- Machine driver for multi abutment



Abutment Holder

- It is an assist device which can be used to easily fix 2-piece abutment which is inconvenient to hand by all areas of oral cavity



Multi Abutment Outer Driver

- Torque driver for multi abutment



Locator® Torque Driver

- Torque driver for locator abutment

Type	Short	Long
	TWLDSK	TWLDLK

Osstem Torque Driver

- As osstem torque driver, it may not be fastened or disconnected when connecting a normal handpiece
- Driver should be used after matching the groove or section of the outer triangle and abutment
- Solid, excellent solid driver is compatible only with $\varnothing 4.8$
- 1.2 hex type L is 5

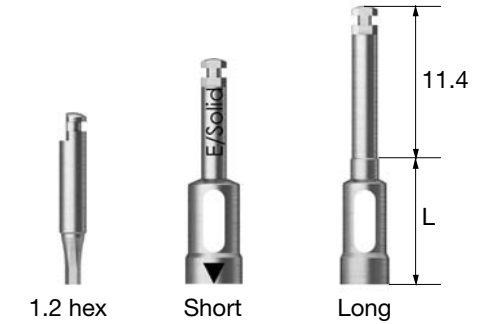

L \ Type	1.2 Hex	Rigid 4.0	Rigid 4.5	Rigid 5.0	Rigid 6.0	Solid	Excellent Solid
Short (10)	OTH12S	OTR40S	OTR45S	OTR50S	OTR60S	OTS48S	OTE48S
Long (15)	-	OTR40L	OTR45L	OTR50L	OTR60L	OTS48L	OTE48L

Path Probe for TS

- After TS fixture placement, check path and measure gingival height
- C = Connection

C	Mini	Regular
	GIPAP-3016A	GIPAP-3516A

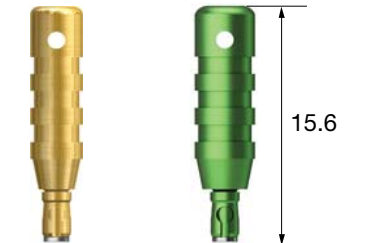

Torque Connector

- It is a connector that connects a square driver for torque to a bi-directional torque wrench

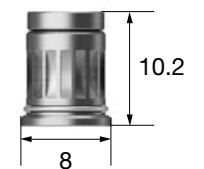
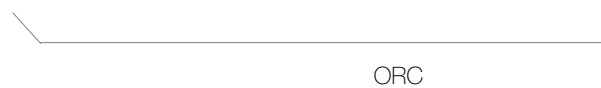

Machine Driver Connector

- It is a connector that connects driver for machine to a bi-directional torque wrench

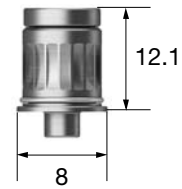

OMDC

Reamer Bite

- After plastic coping casting, it is a cutting edge that removes the lip on the inner surface of casting



FRBC

Driver Handle

- Use it by connecting with torque driver

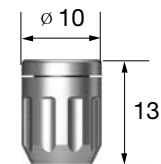

TIDHC

Reamer Tip for Rigid Abutment

- After plastic coping casting, it is a guide part that enters inside when removing lip on inner surface of casting (for rigid abutment)

D	Ø4.0	Ø4.5	Ø5.0	Ø6.0
	GSRFRT400	GSRFRT450	GSRFRT500	GSRFRT600

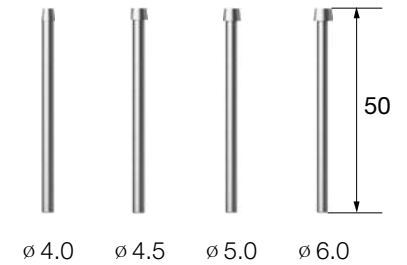

Finishing Reamer Set

- After plastic coping casting, It is a device used to remove lip on the inner surface of casting



FRSC

Reamer user guide

1. Select a reamer tip that is the same size as the abutment, and connect it to the burn-out cylinder
2. Firmly grasp the casting body and rotate the Reamer Bite with consistent force
3. Ream the body until it is clean and free of the excess casting

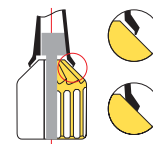

Reamer Tip for Solid, Excellent Solid Abutment

- After plastic coping casting, it is a guide part that enters inside when removing lip on inner surface of casting
- For both solid Ø6.0 and excellent solid Ø4.8
- P= Platform

P	Regular(Ø4.8)	Wide(Ø6.0)
Solid	FRTS480	FRTS600
Ex.Solid	FRTE480	FRTE600

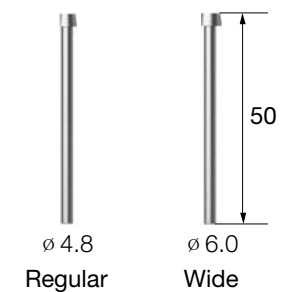

CAS KIT (HCRSNK)



CAS KIT Surgical Instruments

For **TSII / III** **SSII / III** **USII / III**

Top panel components

Lower panel components

Hydraulic Membrane Lifter Tube
SNMT

Bone Carrier Head
SNBCH30



Bone Carrier
SNBCS35



Bone Condenser
SNBC1114

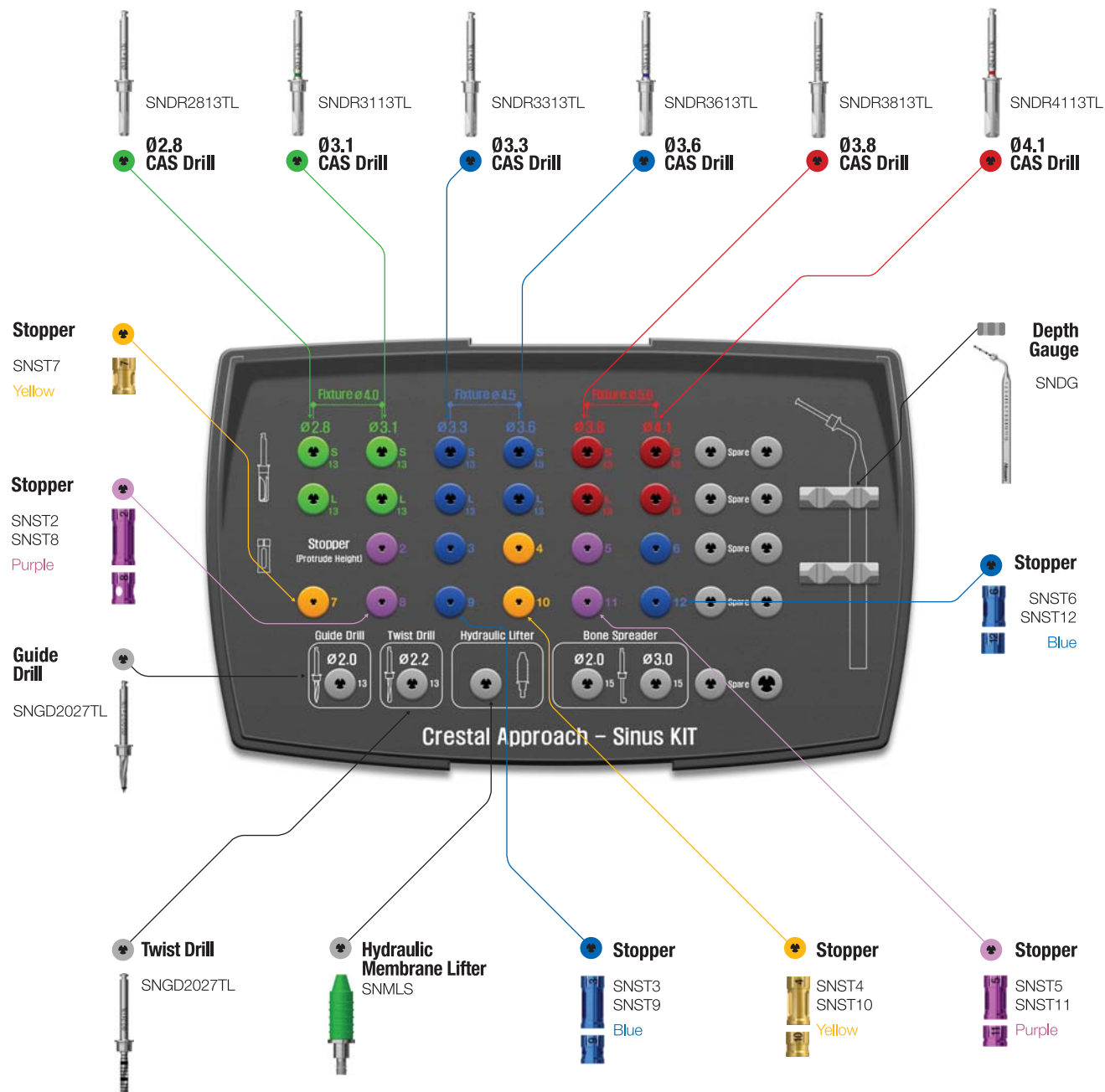

CAS Drill

- Specialized drill designed to penetrate the sinus floor without damaging the Schneiderian membrane by forming a concial bone lid
- Four blade body drills well at both high and low speeds and is capable of collecting autogenous bone at low speeds
- Use with stoppers for safe and controlled penetration
- Final drill should be based on the bone quality, regardless of the fixture type (straight or tapered)
- Recommended speed : 400~800rpm (first time : 400rpm)

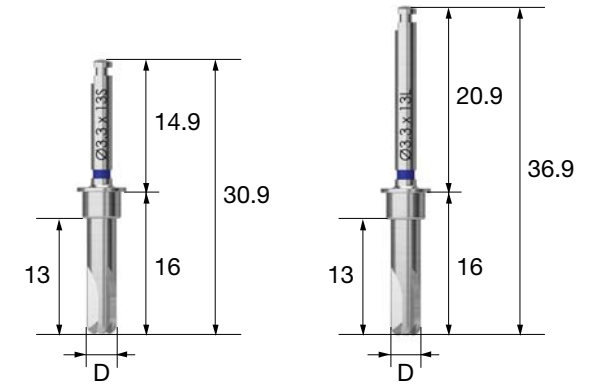

L \ D	Ø2.8	Ø3.1	Ø3.3	Ø3.6	Ø3.8	Ø4.1
Short	SNDR2813TS	SNDR3113TS	SNDR3313TS	SNDR3613TS	SNDR3813TS	SNDR4113TS
Long	SNDR2813TL	SNDR3113TL	SNDR3313TL	SNDR3613TL	SNDR3813TL	SNDR4113TL

Guide Drill

- Marks the fixture's insertion site
- Side cutting blades trim the extraction socket sidewalls
- Marker 2mm from the tip

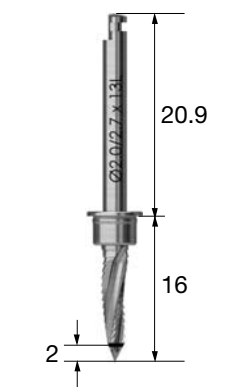

Ø2.2 Twist Drill

- Recommend under-drilling by 1mm less than the bone's thickness
- Use with stoppers for safe and controlled drilling
- The tip measures an additional 0.6mm

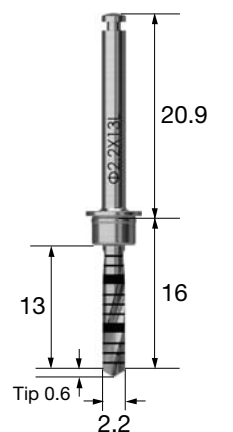
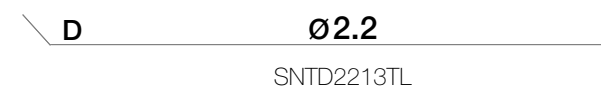

Hydraulic Membrane Lifter Set

- Hydraulic pressure is used to separate and lift the sinus membrane
- Securely fits $\varnothing 2.8 \sim \varnothing 4.1$ CAS drilled osteotomies

D	$\varnothing 2.6 / 6.0$
	SNMLS

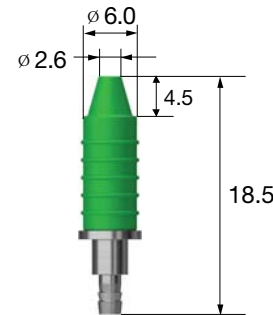

Stopper

- Laser marked numbers indicate the remaining tool's (drill, instruments, etc.) length
- Color-coded by length
- Drill and stopper recommended number of usage is 50 times

L	2	3	4	5	6	7	8	9	10	11	12
Color	Purple	Blue	Yellow	Purple	Blue	Yellow	Purple	Blue	Yellow	Purple	Blue

Bone Carrier

- Handle for the bone carrier head
- Connect the bone carrier head and tighten at the opposite end
- Connects both heads (SNBCH30 or SNBCH35)

	SNBCS35
--	---------



Bone Carrier Head

- Cone shaped with an extended tip that reaches the sinus cavity and prevents bone material from spilling out
- SNBCH30 for $\varnothing 3.1 / 3.3$ CAS drilled osteotomy
- SNBCH35 for $\varnothing 3.6 / 3.8 / 4.1$ CAS drilled osteotomy
- Fill the reservoir with bone material (up to the marker), with the bone condenser shuttle the material in small quantities into the sinus. Repeat the process as necessary.

D	$\varnothing 3.1$	$\varnothing 3.6$
	SNBCH30	SNBCH35

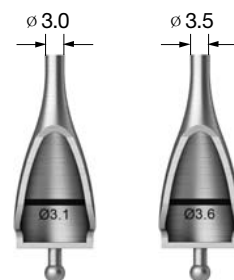

Bone Condenser

- Safely shuttles bone material through the bone carrier head into the sinus cavity
- SNBCH30 : use $\varnothing 1.1$ / SNBCH35 : use $\varnothing 1.4$

D	$\varnothing 1.1 / 1.4$
	SNBC1114



Hydraulic Membrane Lifter Tube

- Tubing connects to the hydraulic membrane lifter and saline filled syringe

	SNMT
--	------



Membrane Lifter

- Round shape, no cutting edge and safe membrane lift
- After the CAS drill is used, the membrane was lifted and the lifter diameter was selected according to the CAS drill diameter (head diameter : CAS drill diameter -0.2mm)
- Using CAS stopper for depth adjustment
- Recommended speed : 400~800rpm (for first user : 400rpm)
- Be sure to spray water when using

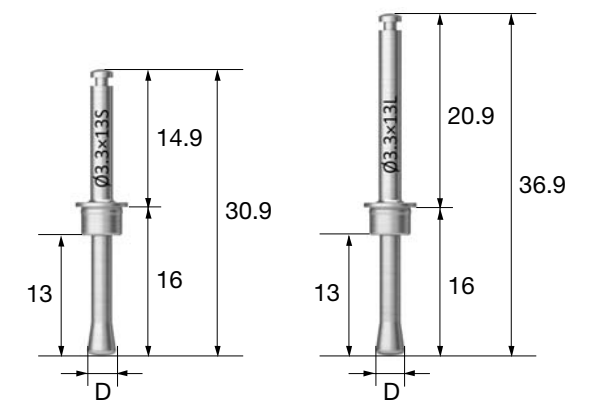

L \ D	$\varnothing 2.6$	$\varnothing 2.9$	$\varnothing 3.1$	$\varnothing 3.4$	$\varnothing 3.6$	$\varnothing 3.9$
Short	SNML2813TS	SNML3113TS	SNML3313TS	SNML3613TS	SNML3813TS	SNML4113TS
Long	SNML2813TL	SNML3113TL	SNML3313TL	SNML3613TL	SNML3813TL	SNML4113TL

Depth Gauge

- Measures the thickness of the residual bone and checks to see if the sinus is properly separated from the floor



SNDG

Bone Spreader

- A tool that spreads a filled bone by using engine
- Used with stopper
- Recommended speed : 30rpm or less (low speed mode)

D	Ø2.0	Ø3.0
	SNBS2015T	SNBS3015T

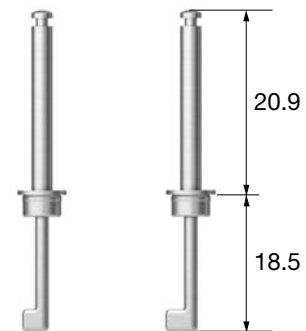

OSSTEM[®]
IMPLANT

Y-Connector

- Y-type connecting tool capable of simultaneous water pressure elevation in two drilling holes



SNYCT

LAS KIT (HLRSNK)



- Lateral Approach - Sinus KIT (LAS KIT) : optimized KIT for lateral approach during maxillary sinus surgery
- Dome drills and core drills safely form a lateral window; available sizes Ø5.5 & 7.0
- Stoppers attach to LAS KIT for safety and form a lateral window without membrane perforation

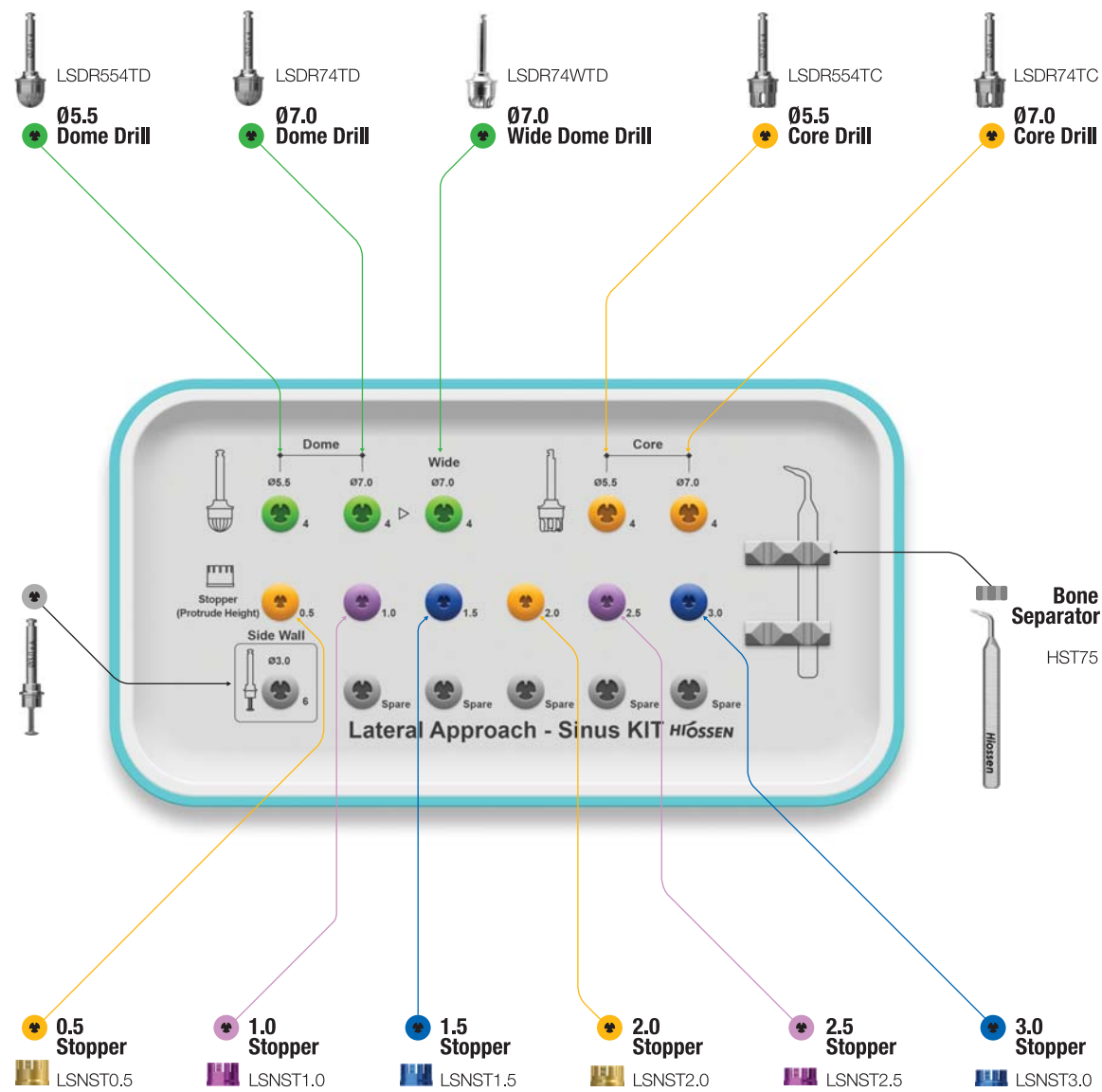

LAS KIT Surgical Instruments

Dome Drill

- Forms a bone window, at the same time collects autogenous bone
- Excellent penetration due to the macro and micro cutting blade combination
- Stopper safely controls the penetration depth
- Recommended speed : 1,200~1,500rpm
- ※ Excessive drilling may cause damage to the membrane

L \ D	Ø5.5	Ø7.0	Wide Ø7.0
25	LSDR554TD	LSDR74TD	LSDR74WTD

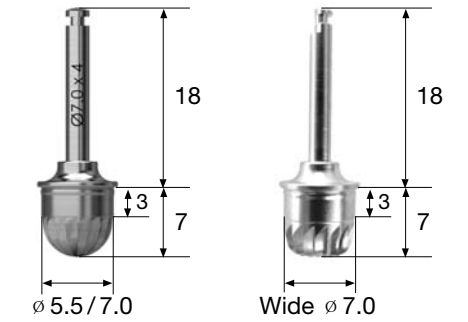

Core Drill

- Forms a bone window and generates a bone lid
- Based on the CAS drill design, excellent cutting ability and no membrane damage
- Recommended speed : 1,200~1,500rpm
- ※ Excessive drilling may cause damage to the membrane

L \ D	Ø5.5	Ø7.0
25	LSDR554TC	LSDR74TC

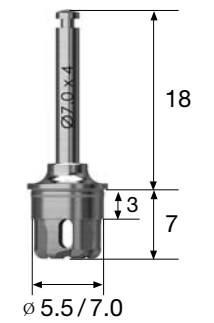

Side Wall Drill

- Enlarges the bone window after using the dome drill
- Cut using the blade 1mm above the bottom of the drill
- Recommended speed : 1,500rpm

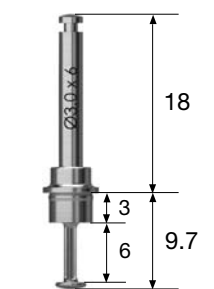

Height of side cutting blade (mm)	1.0	2.0	3.0	4.0	5.0
CAS KIT stopper (mm)	8.0	9.0	10	11	12
Side wall drill + CAS KIT stopper					

※ Stopper safely controls the penetration depth

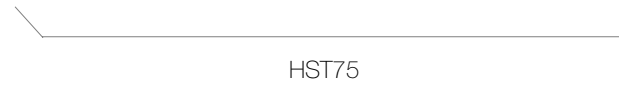

Bone Separator

- Removes the bone lid inside the core drill



Stopper

- Laser marked numbers indicate the remaining tool's (drill, instruments, etc.) length when stopper is fastened
- Color-coded by length
- Drill and stopper recommended number of usage : 50 times

L	0.5	1.0	1.5	2.0	2.5	3.0
						
	LSNST0.5	LSNST1.0	LSNST1.5	LSNST2.0	LSNST2.5	LSNST3.0
Color	Yellow	Purple	Blue	Yellow	Purple	Blue



ESSET KIT (HESEK)



For **TSII / III** **SSII / III** **USII / III**

Lower panel components

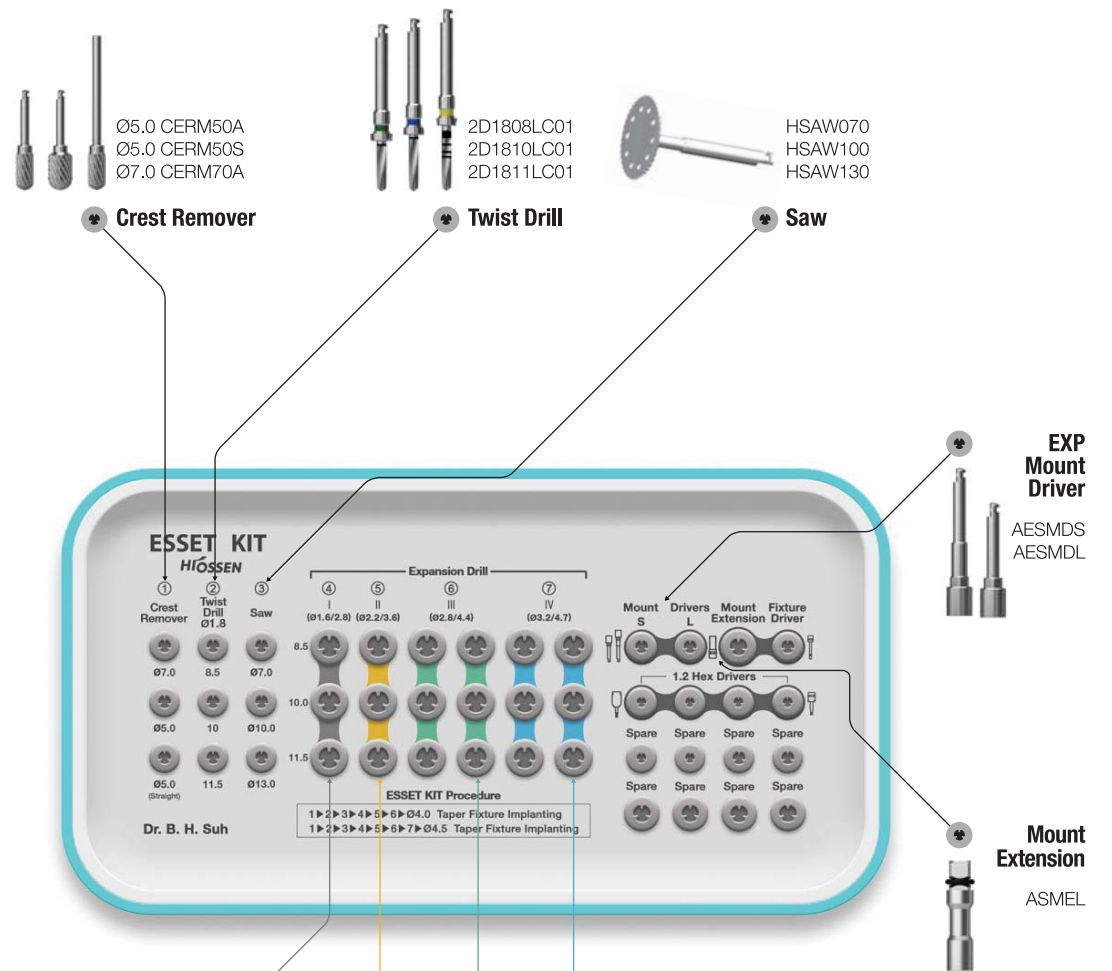
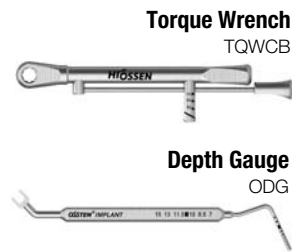

- Crest Remover**
 - Ø5.0 CERM50A
 - Ø5.0 CERM50S
 - Ø7.0 CERM70A
- Twist Drill**
 - 2D1808LC01
 - 2D1810LC01
 - 2D1811LC01
- Saw**
 - HSAW070
 - HSAW100
 - HSAW130

- Expansion Drill**
 - EXP162808
 - EXP162810
 - EXP162811
- Expansion Drill**
 - EXP223608
 - EXP223610
 - EXP223611
- Expansion Drill (2ea)**
 - EXP284408
 - EXP284410
 - EXP284411
- Expansion Drill (2ea)**
 - EXP324708
 - EXP324710
 - EXP324711

ESSET KIT Surgical Instruments

Crest Remover

- Grinds down narrow alveolar ridge, and creates an indentation for the fixture's insertion site
- Angled type recommended speed : 1,200~1,500rpm
- Straight type recommended speed : 15,000~30,000rpm

L \ D	Ø5.0	Ø7.0
29	CERM50A	CERM70A
45	CERM50S	-

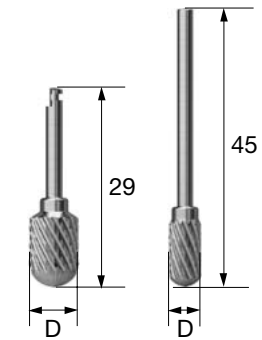

Twist Drill

- Marks the fixture's insertion site
- Slide on the stopper to control the depth
- Recommended speed : 1,200~1,500rpm

L \ TL \ D	Ø1.8
8.5 \ 33	2D1808LC01
10 \ 34.5	2D1810LC01
11 \ 36	2D1811LC01

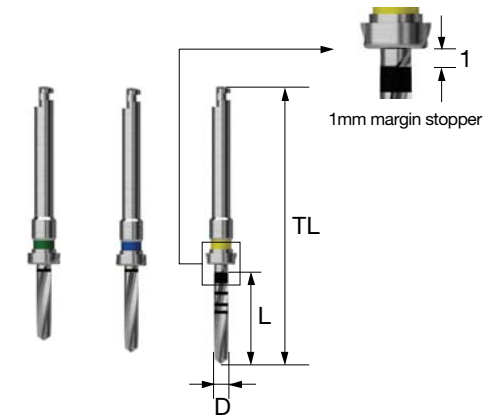

Saw

- Saws narrow alveolar ridge
- Saw vertically first, then saw from the mesial to the distal
- Recommended speed : 1,200~1,500rpm
- Recommended number of use : 10 times
- T = Thickness

T \ D	Ø7.0	Ø10.0	Ø13.0
0.3	HSAW070	HSAW100	HSAW130

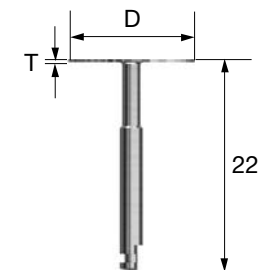

Expansion Drill

- Expands narrow alveolar ridge
- Use the SET drills in numerical order based on the diameter of the fixture
F4.0 : I → II → III / F4.5 : I → II → III → IV
- Recommended speed : 25~35rpm

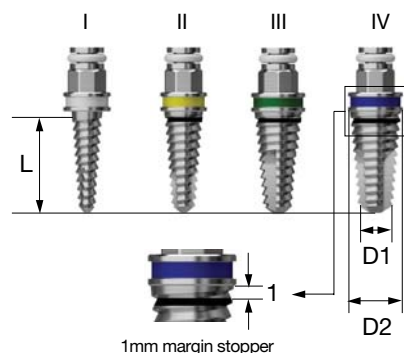

L \ Type	I	II	III	IV
D1 / D2	Ø1.6 / 2.8	Ø2.2 / 3.6	Ø2.8 / 4.4	Ø3.2 / 4.7
8.5	EXP162808	EXP223608	EXP284408	EXP324708
10	EXP162810	EXP223610	EXP284410	EXP324710
11.5	EXP162811	EXP223611	EXP284411	EXP324711

Mount Extension

- Connect with SET drills for manual torque

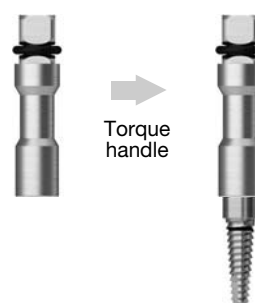

EXP Mount Driver

- In the process of inserting or removing the expansion drill into the alveolar bone, it is used to increase torque

L	
Short (L)	AESMDS
Long (L)	AESMDL

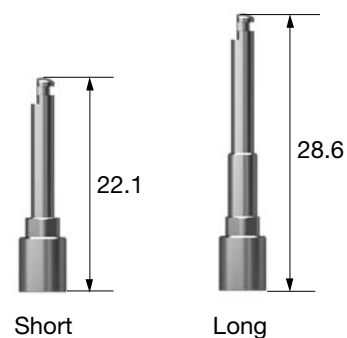

Saw Protector

- Saw cover prevents debris from ejecting outside the oral cavity and protects adjacent soft tissue
- Cover can rotate 360° adding convenience during surgery
- Contra angle type (detachable saw cover)
- KaVo (CL 3-09, S201L), W&H (WS-75)
- Straight type (integrated saw cover) - KaVo (CL10)
- ※ Use an appropriate saw
- ※ Cover and body need to be ordered separately

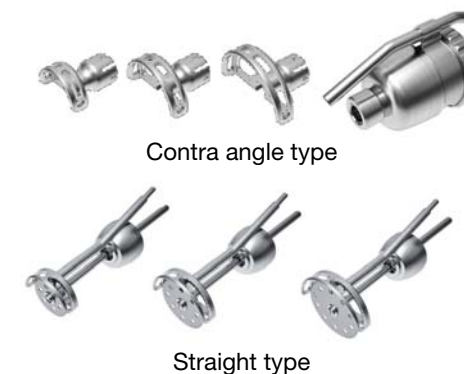

Type \ D		Ø7.0	Ø10.0	Ø13.0	Ø15.0	Full Set
Kavo	Contra Angled					
	Cover Set	SP07AC SP07A	SP10AC SP10A	SP13AC SP13A	- -	- SP071013A
Kavo	Straight					
	Saw Set	- -	SAW10S SP10S	SAW13S SP13S	SAW15S SP15S	- SP101315S
W&H	Contra Angled					
	Cover Set	SP07ACW SP07AW	SP10ACW SP10AW	SP13ACW SP13AW	- -	- SP071013W

Torque Wrench

- Use with mount extension and SET drills



Depth Gauge

- Releases a wedged SET drill due to over torquing and fir when the hand piece ceases because bit is stuck. Use with an open wrench



ESR KIT Easy Screw Removal KIT (OESRK)



ESR Full KIT Easy Screw Removal Full KIT (OESRFK)

• It is a KIT that has the same components as ESR KIT and can be mounted on competitors' components

For **Nobel Biocare** Active/Replace / **Straumann** Bone Level / **Astra** Osseo Speed TX
3i Full OSSEOTITE Tapered Certain / **Zimmer** Tapered / **Biohorizons** Internal

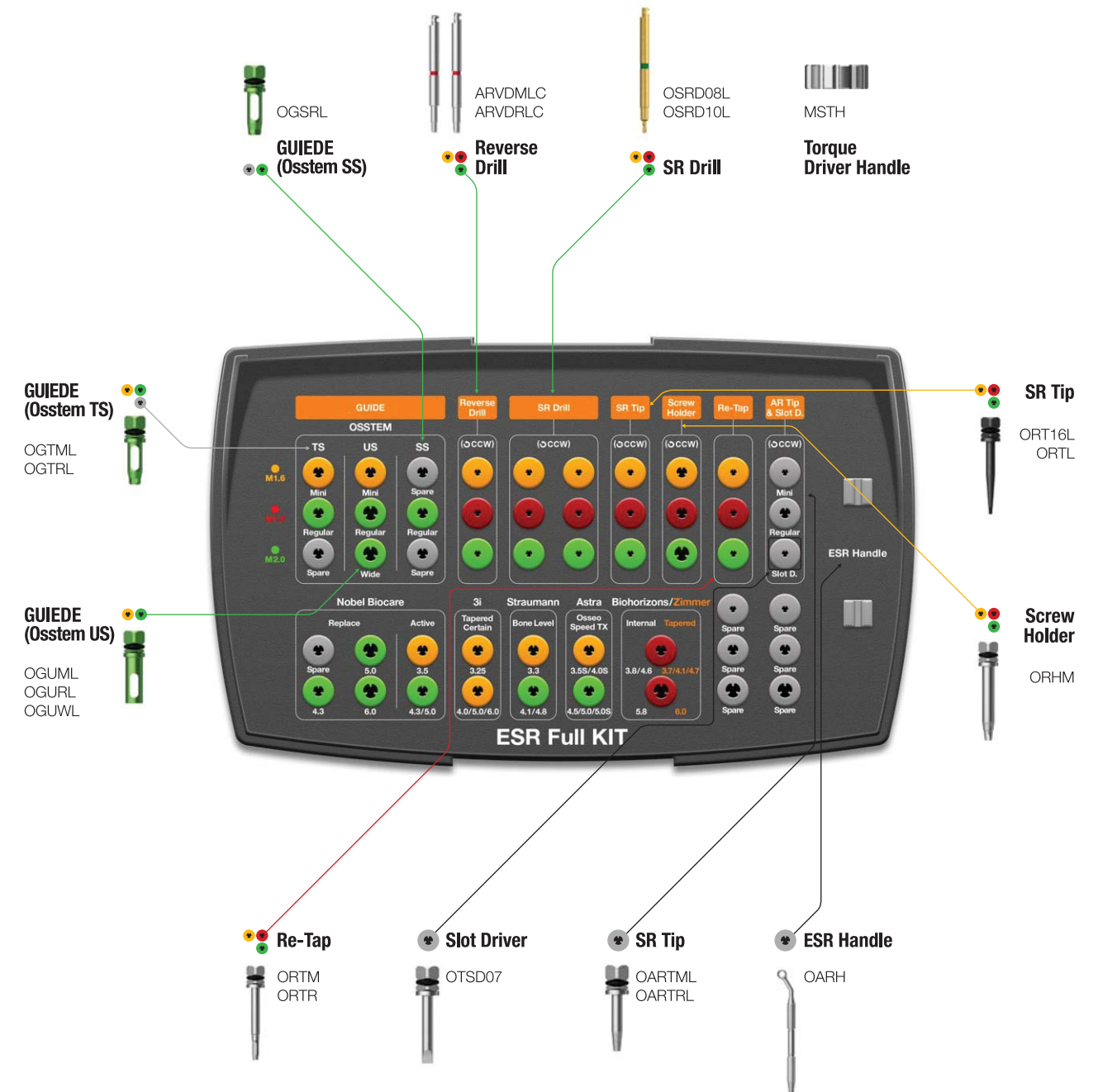
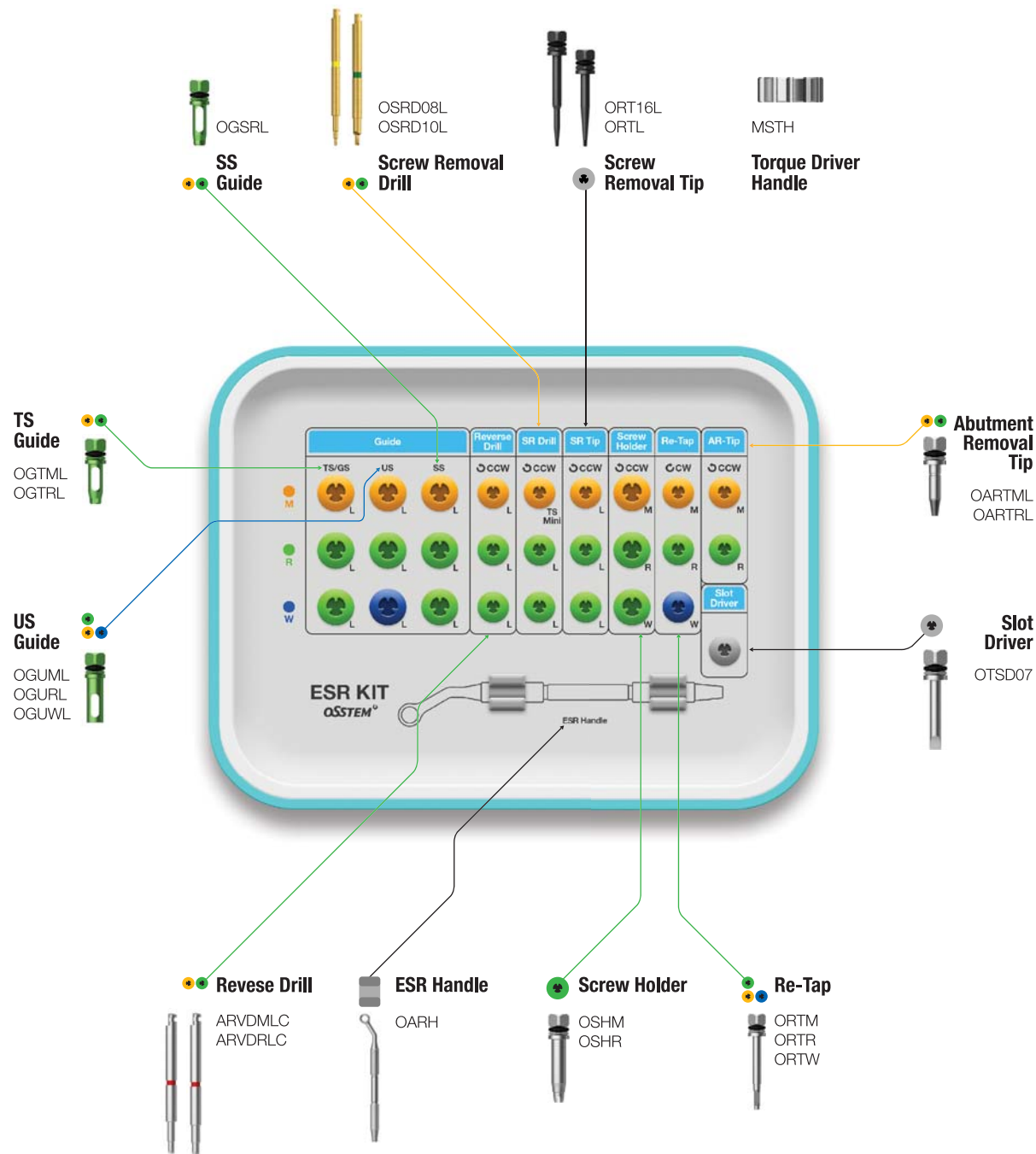

ESR Full KIT Surgical Instruments

Items that are not included in the KIT

Guide								
Nobel	Active	Replace	3i	Tapered Certain		Straumann	Bone Level	Roxolid SLActive
	OGNA01L OGNA02L	OGNR02L OGNR03L OGNR04L		OGIF01L OGIF02L			OGSB01L OGSB02L	OGSTROS OGSTROL
Astra	Osseo Speed TX		Biohorizons	Internal	External	Zimmer	Tapered	
	OGAO01L OGAO02L			OGZB01L OGZB02L	OGUBS OGUBL		OGZB01L OGZB02L	
SR Drill		SR Tip		Screw Holder		Re-Tap		
OSRD09L		ORT18L		OSHR18L		ORTR18L		

Guide

- It is fixed to the fixture to prevent shaking of SR drill and SR tip
- Use according to fixture type and diameter
(6 overseas companies' internal and submerged type products)
- Select short or long depending on opposite teeth's distance
- ■ Common use
- C = Connection / F = Fixture / the number of use : 10 times

Osstem

C \ Type	TS		SS		US	
	Short	Long	Short	Long	Short	Long
Mini	OGTMS	OGTML	OGUMS	OGUML	OGUMS	OGUML
Regular	OGTRS	OGTRL	OGSRS	OGSRL	OGURS	OGURL
Wide	-	-	OGSRS	OGSRL	OGUWS	OGUWL

Nobel Biocare

F \ Type	Active		Replace	
	Short	Long	Short	Long
Ø4.3	OGNA02S	OGNA02L	OGNR02S	OGNR02L
Ø5.0	OGNA02S	OGNA02L	OGNR03S	OGNR03L
Ø6.0	-	-	OGNR04S	OGNR04L

Nobel Biocare

F \ Type	MkIII	
	Short	Long
Ø3.3	OGUMS	OGUML
Ø3.75	OGURS	OGURL
Ø4.0	OGURS	OGURL
Ø5.0	OGUWS	OGUWL

Straumann

F \ Type	Bone Level	
	Short	Long
NC (3.3)	OGSB01S	OGSB01L
RC (4.1)	OGSB02S	OGSB02L
RC (4.8)	OGSB02S	OGSB02L

F \ Type	Roxolid SLActive	
	Short	Long
RN (3.3)	OGSTROS	OGSTROL
RN (4.1)	OGSTROS	OGSTROL
RN (4.8)	OGSTROS	OGSTROL
WN (4.8)	OGSTROS	OGSTROL

Astra

F \ Type	Osseo Speed TX	
	Short	Long
Small (3.5 S)	OGAO01S	OGAO01L
Small (4.0 S)	OGAO01S	OGAO01L
Large (4.5)	OGAO02S	OGAO02L
Large (5.0)	OGAO02S	OGAO02L
Large (5.0 S)	OGAO02S	OGAO02L

3i

F \ Type	Full Osseotite Tapered Certain	
	Short	Long
3.25	OGIF01S	OGIF01L
4.0	OGIF02S	OGIF02L
5.0	OGIF02S	OGIF02L
6.0	OGIF02S	OGIF02L

F \ Type	Full Osseotite Tapered	
	Short	Long
Ø4.0	OGURS	OGURL
Ø5.0	OGURS	OGURL
Ø6.0	OGURS	OGURL

Reverse Drill

- Equipment used to remove fracture screw
- Be sure to use with guide that matches fixture
- If the red marking of the reverse driver is visible on the guide fastened to the fixture, remove the fracture screw using a screw holder
- For hand mode / Direction of rotation : counterclock wise / The number of use : 10 times
- F = Fixture

L \ Type	M1.6	M1.8	M2.0
Short	-	ARVDRSC	ARVDRSC
Long	ARVDMLC	ARVDRLC	ARVDRLC

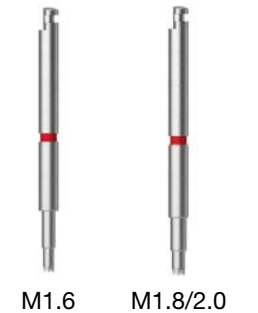

Zimmer

F \ Type	Tapered	
	Short	Long
Green (3.7)	OGZB01S	OGZB01L
Green (4.1)	OGZB01S	OGZB01L
Green (4.7)	OGZB01S	OGZB01L
Green (6.0)	OGZB02S	OGZB02L

Screw Removal Drill (SR Drill)

- Used to remove for the formation of holes in the fractured screw
- Make sure to connect the guide, irrigate with saline solution and remove any debris by suction
- Available in long and short lengths for different intermaxillary distances
- Drill until the red color marker is no longer visible
- Recommended speed: 1,200~1,500 rpm (counterclock wise) / Number of uses : 5 times
- ※ Connect the guide before use/Do not apply excessive vertical force / Do not clean with hydrogen peroxide
- ※ Disposable; do not re-use
- Short : single unit purchase available

L \ Type	M1.6	M1.8	M2.0
Short	OSRD08S	OSRD09S	OSRD10S
Long	OSRD08L	OSRD09L	OSRD10L

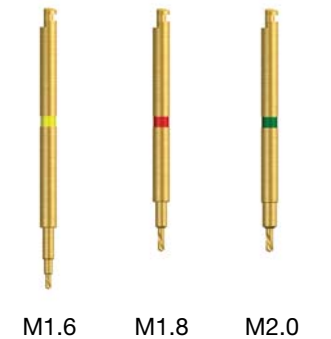

Biohorizons

F \ Type	Internal (Tapered Bone Level)	
	Short	Long
Yellow	OGZB01S	OGZB01L
Green	OGZB01S	OGZB01L
Blue	OGZB02S	OGZB02L

F \ Type	External	
	Short	Long
Ø3.5	OGUMS	OGUML
Ø4.0	OGURS	OGURL
Ø5.0	OGUBS	OGUBL
Ø6.0	OGUBS	OGUBL

Torque Driver Handle

- Manual handle for SR Tip, AR Tip, screw holder



ESR Full KIT Surgical Instruments

Reverse Driver

- Removes fractured screws
- Select the appropriate guide that matches the fixture
- Operate the driver in reverse, when the red marker appears above the guide, stop and disconnect the driver. Connect the screw holder to remove the screw.
- For hand mode / Rotate counterclock wise / Number of usages : 10 times
- F = Fixture

L \ F	Mini	Regular/Wide
Short	-	ORVDRS
Long	ORVDML	ORVDRL



Re-tap

- Re-threads the internal connection of a fixture, if the screw does not properly engage and tightens
- Connects to a torque wrench or ratchet wrench to re-thread

Type	M1.6	M1.8	M2.0
	ORTM	ORTR18	ORTR



Screw Removal Tip (SR Tip)

- Engage counterclock wise into the drilled hole made by the screw removal drill (SR drill) of a fractured screw, continue to rotate to remove screw
- Rotation direction : counterclock wise

L \ Type	M1.6	M1.8	M2.0
Short	ORT16S	ORT18S	ORTS
Long	ORT16L	ORT18L	ORTL



ESR Handle

- Tools to fix guide to fixture

	OARH
--	------



Screw Holder

- Grasps onto a protruding fracture screw and unscrews it
- Color-coded
- Rotation direction : counterclock wise

Type	M1.6	M1.8	M2.0
	OSHM	OSHR18	OSHR



Abutment Removal Tip (AR Tip)

- Removes the remaining part of a fractured abutment or mount in a fixture.
- Engage the tip into the fractured abutment counterclock wise. Using forceps, grasp the removal tip and rock back and forth until the fractured abutment is freed.
- Mini : it can be used to remove a screw with a stripped hex
- To remove the screw, engage the tip into the stripped hex and rotate counterclock wise

L \ Type	Mini	Regular
Short	OARTMS	OARTRS
Long	OARTML	OARTRL
Ex.Long	OARTMEL	OARTREL



Slot Driver

- Cut a slot on a stripped hex; healing abutment, cover screw, or abutment screw using a Ø0.8 bur to unscrew



Transfer Abutment Separate Tool

- Removes stuck or wedged non-hex transfer abutments
- Separate tool tip fits mini abutments; regular tools can also be used through the second groove
- After removing the abutment screw, insert the separate tool body into the abutment. Fasten the driver, securely joining the separate tool body and abutment. Remove the abutment. If this does not release abutment from the fixture, retighten with a ratchet wrench to the driver and try again.

Driver	Body	Set
TASD	TASB	TAST



Driver



Body

OSSTEM[®]
IMPLANT

EFR KIT Easy Fixture Removal KIT (OSFRK)



Top panel components

Fixture Wrench
FRDFE



For **TSII / III** **SSII / III** **USII / III** **Ultra-wide**

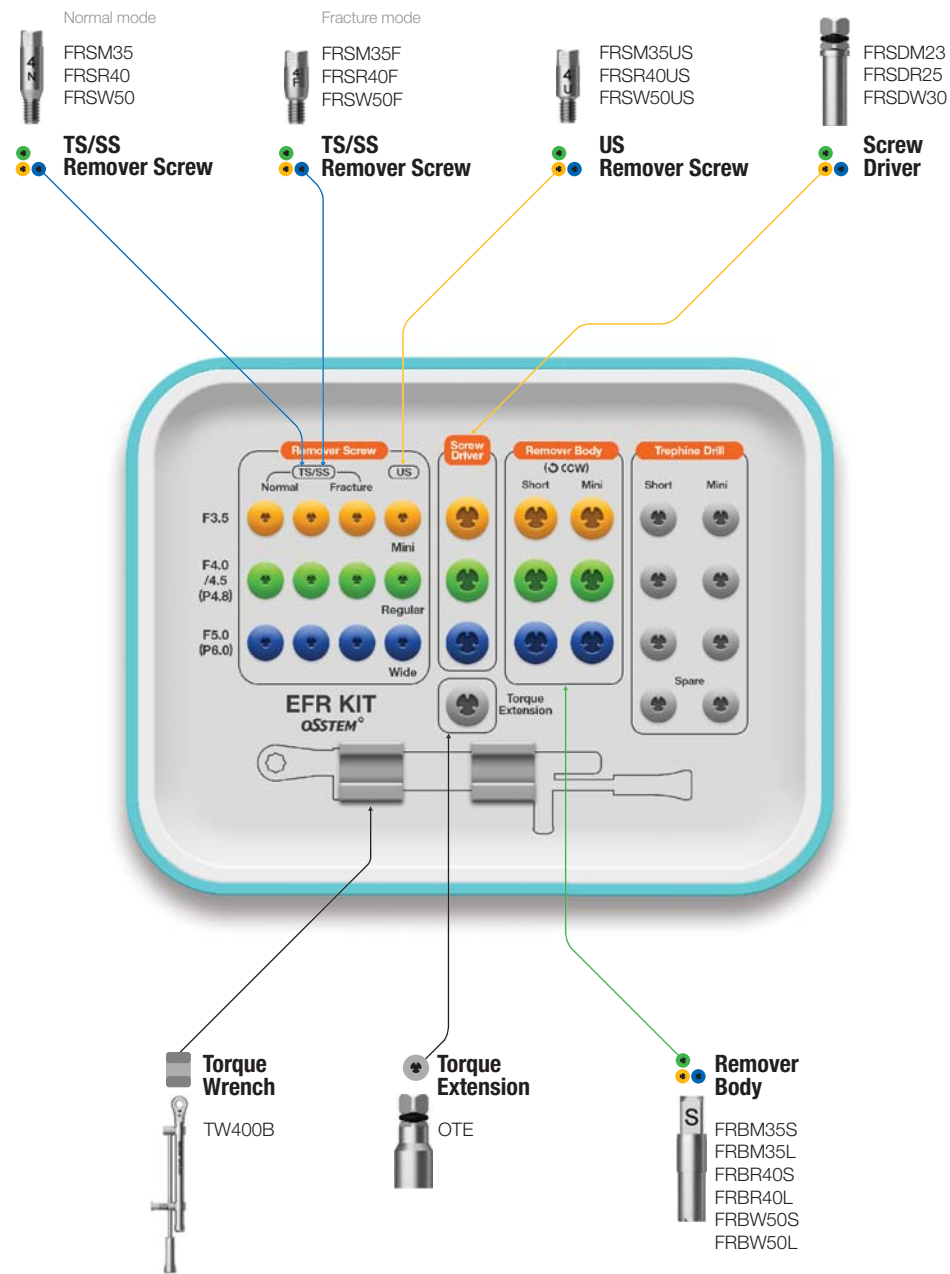

EFR Full KIT Easy Fixture Removal Full KIT (OSFRFK)

• KIT has the same components as EFR KIT and can be put on competitors' components

Lower panel components

Fixture Wrench
FRDFE



Torque Wrench
TW400B



For **Nobel Biocare** Active/Replace / **Straumann** Bone Level / **Astra** Osseo Speed TX
3i Full OSSEOTITE Tapered Certain / **Zimmer** Tapered / **Biohorizons** Internal

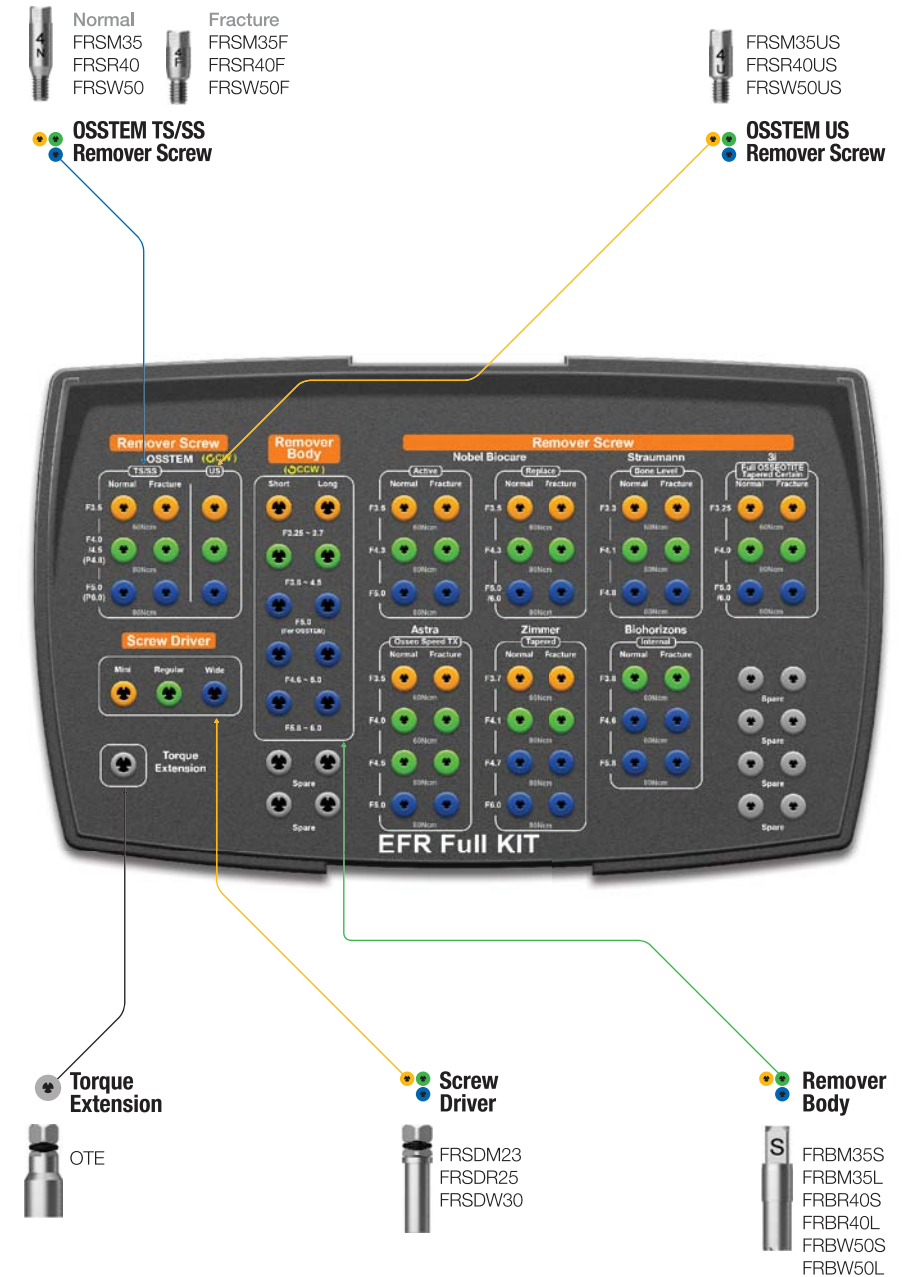

EFR Full KIT Surgical Instruments

Items that are not included in the KIT

Remover Screw								
Nobel	Active		Replace					
	Normal	Fracture	Normal	Fracture				
	FRSMNA35	FRSMNA35F	FRSMNR35	FRSMNR35F				
	FRSR40	FRSR40F	FRSR40	FRSR40F				
	FRSW50	FRSW50F	FRSW50	FRSW50F				
Straumann	Bone Level		3i	Full Osseotite Tapered Certain		Biohorizons	Internal	
	Normal	Fracture		Normal	Fracture		Normal	Fracture
	FRSM33	FRSM33F		FRSMI325	FRSMI325F		FRSRZ41	FRSRZ41F
	FRSR41	FRSR41F		FRSRI40	FRSRI40F		FRSWZ47	FRSWB46F
	FRSWS48	FRSWS48F		FRSWI50	FRSWI50F		FRSWZ60	FRSWB46F
Zimmer	Tapered		Astra	Osseo Speed TX		Remover Body		
	Normal	Fracture		Normal	Fracture	FRBW57S		
	FRSMZ37	FRSMZ37F		FRSMNA35	FRSMNA35F	FRBW57L		
	FRSRZ41	FRSRZ41F		FRSRA40	FRSRA40F	FRBUW60S		
	FRSWZ47	FRSWZ47F		FRSR40	FRSR40F	FRBUW60L		
	FRSWZ60	FRSWZ47F		FRSW50	FRSW50F			

Remover Screw

- Connects to the failed implant and serves to support the remover body
- Available in different sizes to match the diameter of the fixture to be removed (TS/SS/US, normal/fracture)
- Fracture type is specifically for removing a fractured fixture
- Recommended tightening torque : regular/wide 100Ncm, mini 80Ncm
- ※ Disposable; do not re-use
- T = Type



Osstem

T \ Mode	Mini Ø3.5/-	Regular Ø4.0~4.5/P4.8	Wide Ø5.0/P6.0
TS/SS	Normal	FRSM35	FRSR40
	Fracture	FRSM35F	FRSR40F
US	FRSM35US	FRSR40US	FRSW50US

Nobel Biocare

T \ Mode	Mini Ø3.5	Regular Ø4.3	Wide Ø5.0/6.0
Active	Normal	FRSMNA35	FRSR40
	Fracture	FRSMNA35F	FRSR40F
Replace	Normal	FRSMNR35	FRSR40
	Fracture	FRSMNR35F	FRSR40F

Straumann

T \ Mode	Mini Ø3.3	Regular Ø4.1	Wide Ø4.8
Bone Level	Normal	FRSMS33	FRSRS41
	Fracture	FRSMS33F	FRSRS41F
			FRSWS48
			FRSWS48F

Astra

T \ Mode	Mini Ø3.5	Regular Ø4.0	Regular Ø4.5	Wide Ø5.0
Osseo Speed TX	Normal	FRSMNA35	FRSRA40	FRSR40
	Fracture	FRSMNA35F	FRSRA40F	FRSR40F
				FRSW50
				FRSW50F

3i

T \ Mode	Mini Ø3.25	Regular Ø4.0	Wide Ø5.0/6.0
Full Osseotite Tapered Certain	Normal	FRSMI325	FRSRI40
	Fracture	FRSMI325F	FRSRI40F
			FRSWI50
			FRSWI50F

Zimmer

T \ Mode	Mini Ø3.7	Regular Ø4.1	Wide Ø4.7	Ultra-wide Ø6.0
Tapered	Normal	FRSMZ37	FRSRZ41	FRSWZ47
	Fracture	FRSMZ37F	FRSRZ41F	FRSWZ47F
				FRSWZ60
				FRSWZ47F

Biohorizons

T \ Mode	Mini Ø3.8	Regular Ø4.6	Wide Ø5.8
Internal	Normal	FRSRZ41	FRSWZ47
	Fracture	FRSRZ41F	FRSWB46F
			FRSWZ60
			FRSWB46F

EFR Full KIT Surgical Instruments

Screw Driver

- Connects and fastens the remover screw to the fixture
- Recommended tightening torque : regular/wide 100Ncm, mini 80Ncm
- F = Fixture



F	Mini	Regular	Wide
	FRSDM23	FRSDR25	FRSDW30

Torque Wrench

- Connect with screw driver to fasten and remover body to remove the fixture
- Applies up to 400Ncm of torque (markers at 80/100/200/300/400Ncm)
- Torque by pulling the bar back until reaching the desired torque value
- Clean and sterilize for storage



	TW400B
--	--------

Remover Body

- Connects to a failed fixture via the remover screw and by applying counterclock wise torque, removes the implant
- Available in different sizes to match the diameters of the fixture to be removed
- ※ Disposable; do not re-use
- F = Fixture



F	Mini	Regular	Only for osstem Wide	Only for overseas companies Wide	Ultra-wide
Short	FRBM35S	FRBR40S	FRBW50S	FRBW57S	FRBUW60S
Long	FRBM35L	FRBR40L	FRBW50L	FRBW57L	FRBUW60L

Fixture Wrench

- Removes implants from the remover body after removing the fixture from the bone



	FRDFE
--	-------

Torque Extension

- Extends the length of the screw driver and remover body (by 10mm)



	OTE
--	-----

Dr. Cho's Instrument KIT (DCHOKIT)

- Based on many years of clinical know-how, it has been selected to be the best implant surgery KIT
- 10 kinds of instruments (1ea for each)

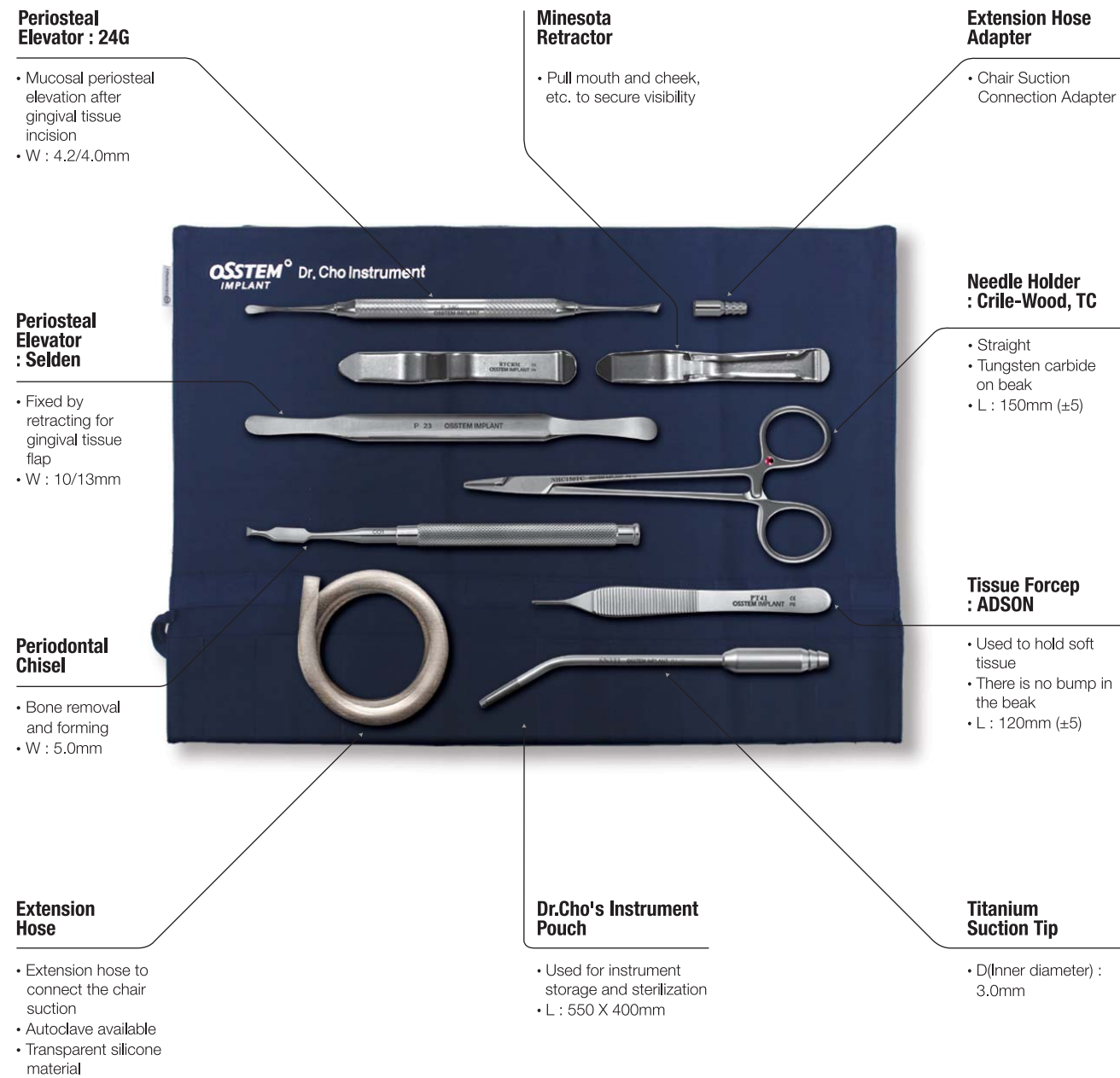

Periosteal Elevator : 24G

- Mucosal periosteal elevation after gingival tissue incision
- W : 4.2/4.0mm

Minesota Retractor

- Pull mouth and cheek, etc. to secure visibility

Extension Hose Adapter

- Chair Suction Connection Adapter

Periosteal Elevator : Selden

- Fixed by retracting for gingival tissue flap
- W : 10/13mm

Needle Holder : Crile-Wood, TC

- Straight
- Tungsten carbide on beak
- L : 150mm (±5)

Tissue Forcep : ADSON

- Used to hold soft tissue
- There is no bump in the beak
- L : 120mm (±5)

Periodontal Chisel

- Bone removal and forming
- W : 5.0mm

Extension Hose

- Extension hose to connect the chair suction
- Autoclave available
- Transparent silicone material

Dr.Cho's Instrument Pouch

- Used for instrument storage and sterilization
- L : 550 X 400mm

Titanium Suction Tip

- D(Inner diameter) : 3.0mm

Osstem Basic Instrument KIT (OBKIT)

- Commonly used Implant surgery KIT
- 25 species Instrument (1ea each)

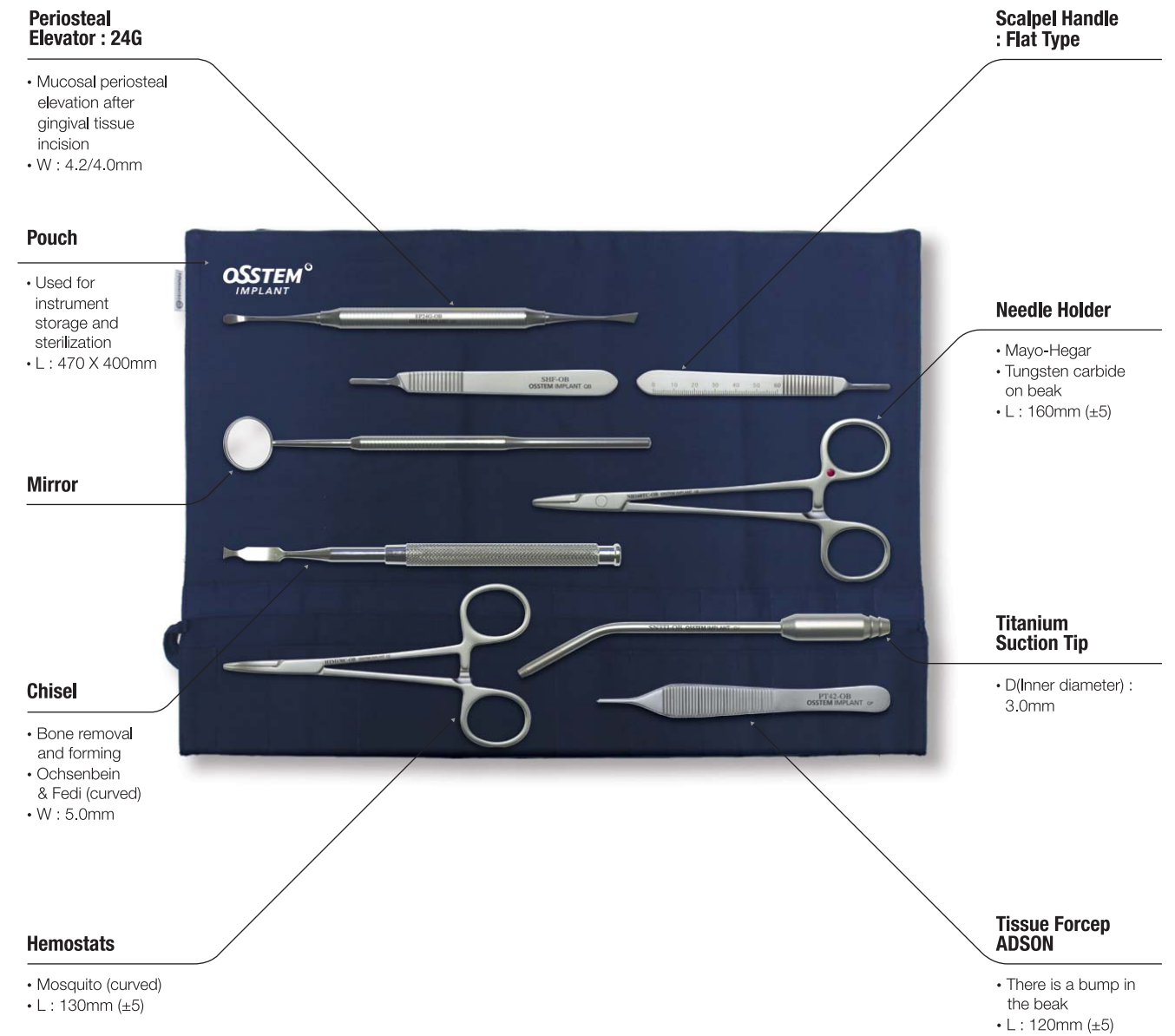

Periosteal Elevator : 24G

- Mucosal periosteal elevation after gingival tissue incision
- W : 4.2/4.0mm

Scalpel Handle : Flat Type

Needle Holder

- Mayo-Hegar
- Tungsten carbide on beak
- L : 160mm (±5)

Pouch

- Used for instrument storage and sterilization
- L : 470 X 400mm

Mirror

Chisel

- Bone removal and forming
- Ochsenbein & Fedi (curved)
- W : 5.0mm

Titanium Suction Tip

- D(Inner diameter) : 3.0mm

Hemostats

- Mosquito (curved)
- L : 130mm (±5)

Tissue Forcep ADSON

- There is a bump in the beak
- L : 120mm (±5)

Osstem Basic Instrument KIT (OBKIT)

Periosteal Elevator : Selden

- Fixed by retracting for gingival tissue flap
- W : 10/13mm

Caliper

- Castroviejo

Scissor : LaGrange

- Compound (curved)
- L : 115mm (±5)

Bone Well

Minesota Retractor

Surgical Curettes : Gracey

Surgical Curettes : Surgical Curette, CM11

Towel Clamp

- Towel Clamp, Backhaus
- L : 135mm (±5)

Periosteal Elevator : MOLT9

- Mucosal periosteal elevation after gingival tissue incision
- W : 8.2/4.2mm

Tweezer (Wide)

- L : 155mm

Scalpel Handle : Straight Type

Bone Rongeurs

- Friedman
- L : 140mm (±5)

Scissor : Tissue Scissor

- Straight
- L : 115mm (±5)

Surgical Curettes : Surgical Curette, CM10

Mallet

- Autoclave available

Periosteal elevator : Prichard

- W : 11/4.9mm

Custom KIT (OCTK)

- Sterilizable case for storing extra tools
- Includes three types of rubber (large, medium, and small) holders
- Sterilization parameters (132°C, 15min)

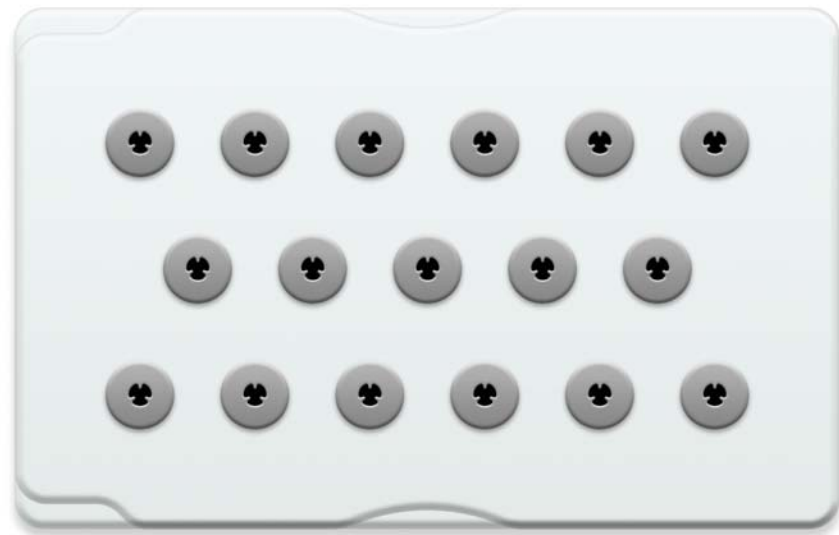

OSSTEM[®]
IMPLANT

Osteo KIT (OSTK)

- Crestal approach sinus lift surgery
- Osteotome is designed to compact bone while penetrating the sinus floor
- Includes stopper system for safe and controlled penetration

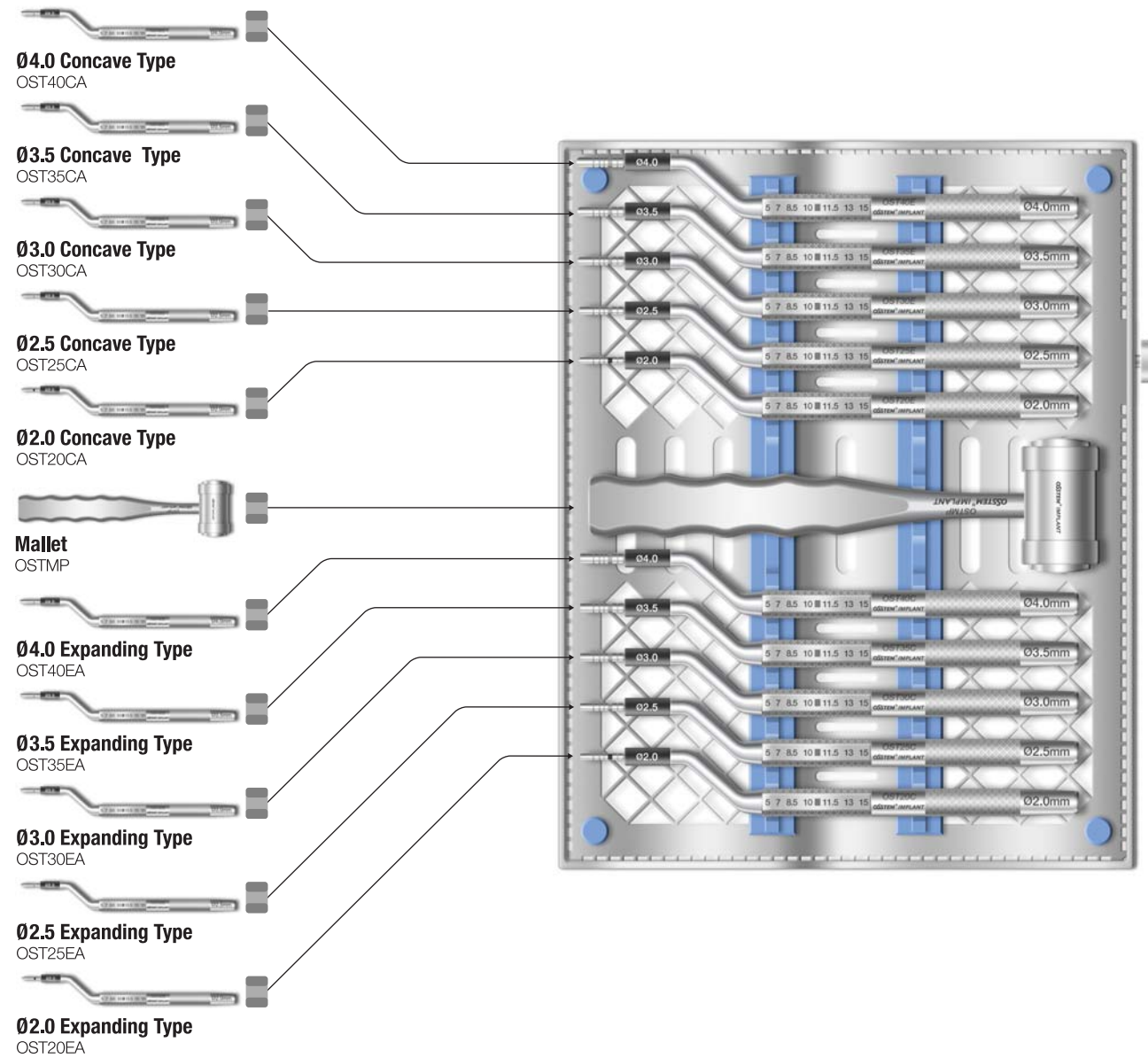

Osteotome KIT (AOST)

- Crestal approach sinus lift surgery
- Concave type only
- Includes stopper system for safe and controlled penetration

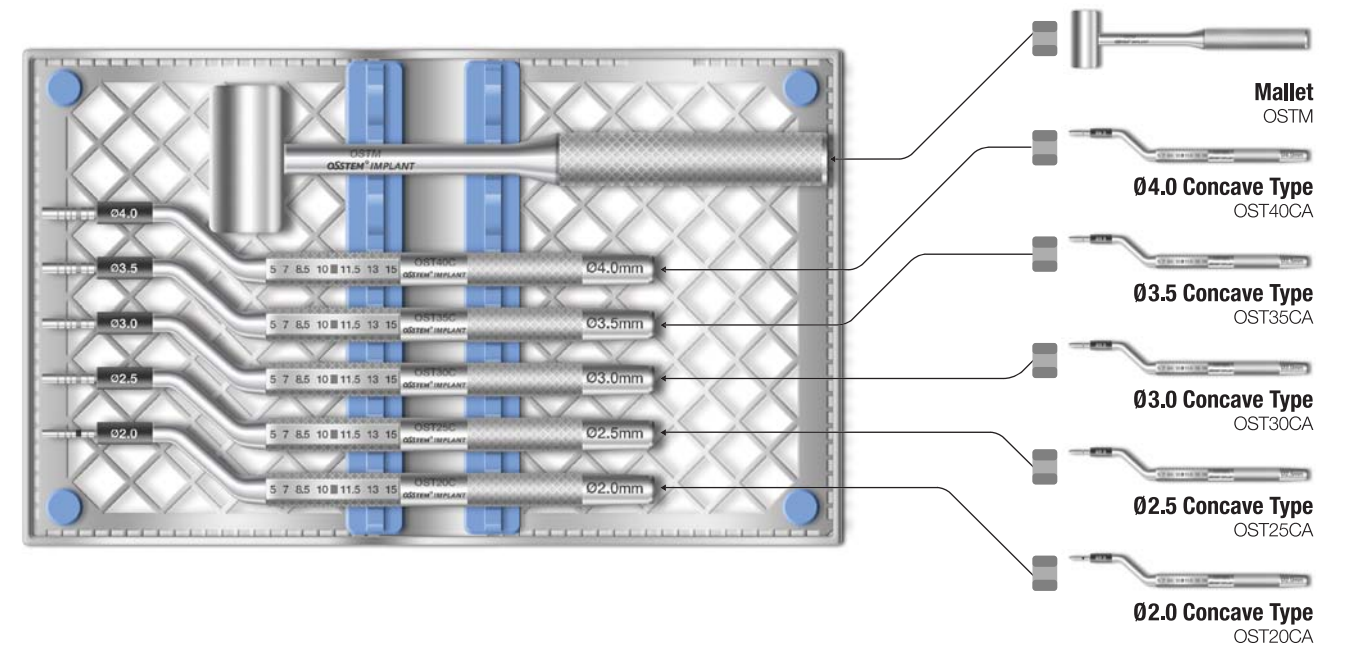

Osteotome Stopper

- Stopper for adjusting the depth

D	Ø2.0	Ø2.5	Ø3.0	Ø3.5	Ø4.0
	OST20SH	OST25SH	OST30SH	OST35SH	OST40SH

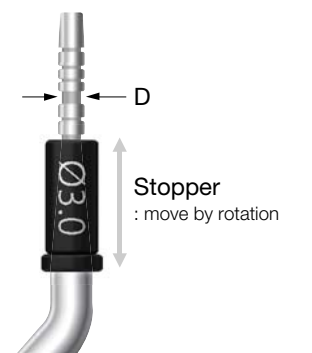

Sinus KIT (ASLK)

- Tools for lateral approach sinus floor elevation surgery
- Components (5 types)
 - Freer elevator : OFE
 - Bone graft carrier : OBGC
 - Membrane separator (circle type) : OMSC
 - Sinus curette-short : OSCS
 - Sinus curette-long : OSCL

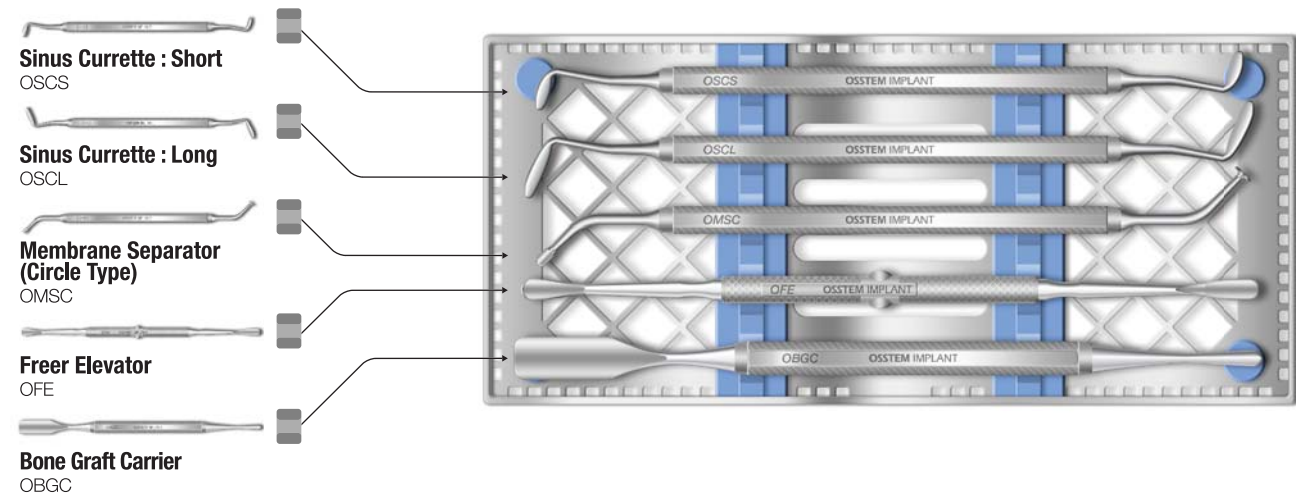

Bone Spreader KIT (OBSOK)

- Expands narrow alveolar ridge
- Offset type
- Components (4 types)
 - OBSO22F, OBSO28F, OBSO35F, OBSO35R

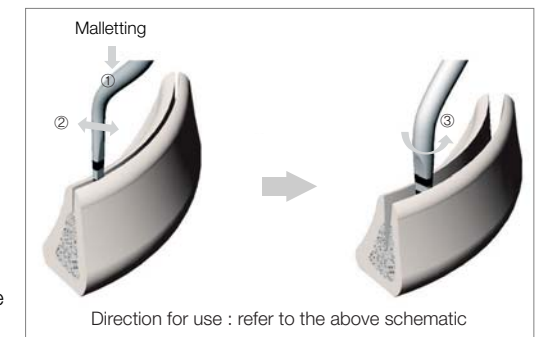
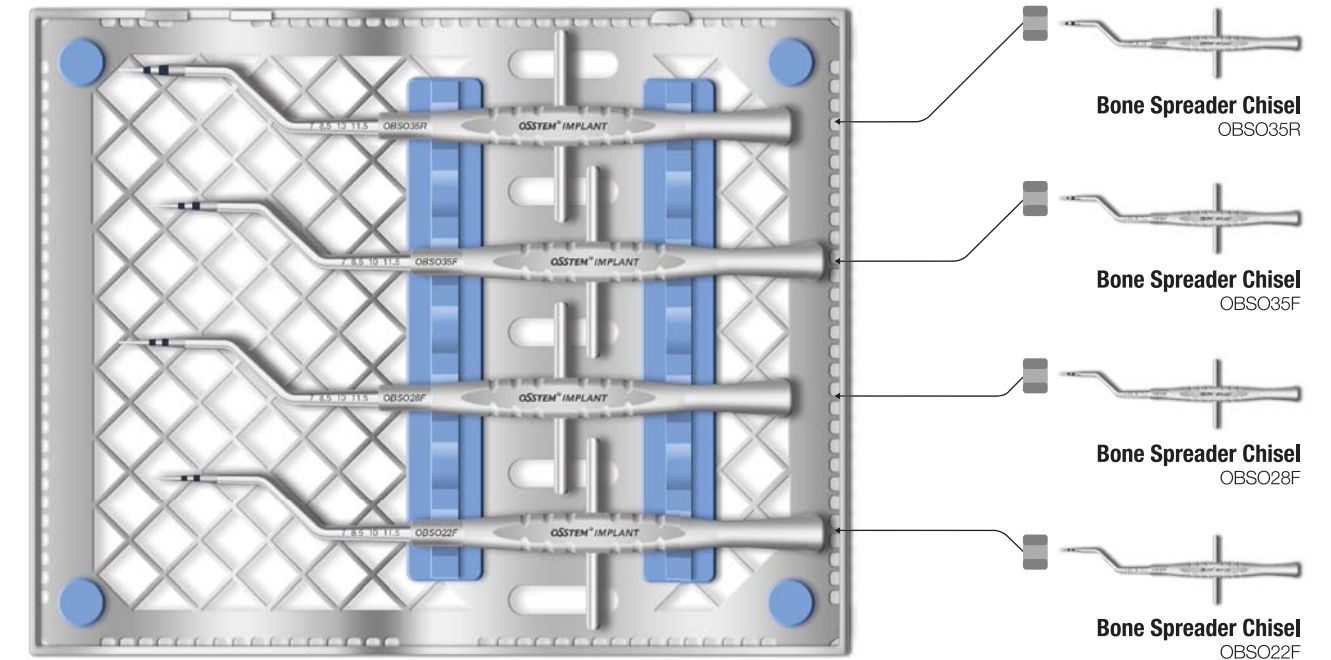

- Use for alveolar bone expansion
- Offset type for easy operation
- Depth marking corresponding to the implant length

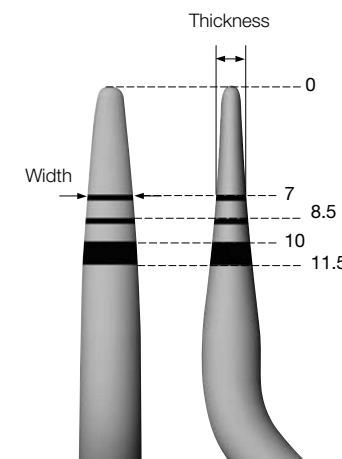

		(Unit : mm)			
Code	Spec.	Tip length			
		7	8.5	10	11.5
OBSO22F	Thickness	1.15	1.3	1.45	1.6
	Width	2.1	2.2	2.2	2.2
OBSO28F	Thickness	1.15	1.3	1.45	1.6
	Width	2.65	2.8	2.8	2.8
OBSO35F	Thickness	1.3	1.45	1.6	1.8
	Width	3.3	3.5	3.5	3.5
OBSO35R (round type)	Thickness	1.85	2.1	2.3	2.55
	Width	3.3	3.5	3.5	3.5

Ridge Split KIT Straight (ORSSK)

Straight

- Chisel : expands narrow alveolar ridge
- Blade holder : cuts poor bone quality using a bur, malletting is possible, use a #15 blade
- Components
 - Ridge split chisel : ORSS15, ORSS20, ORSS25, ORSS30
 - Blade holder : ORSBH

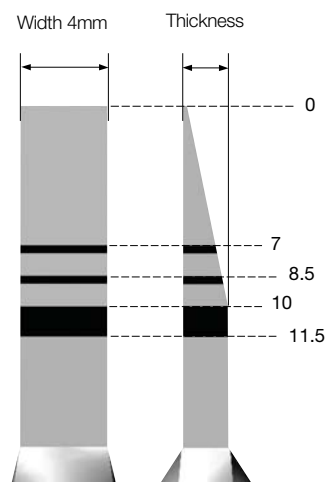
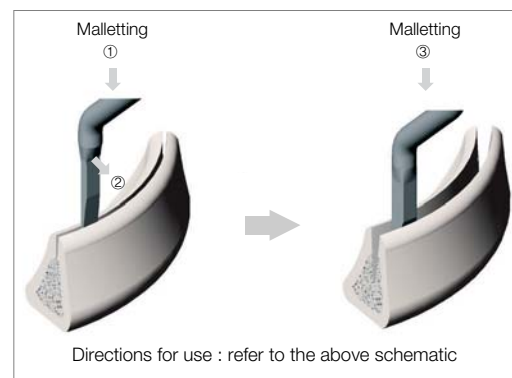
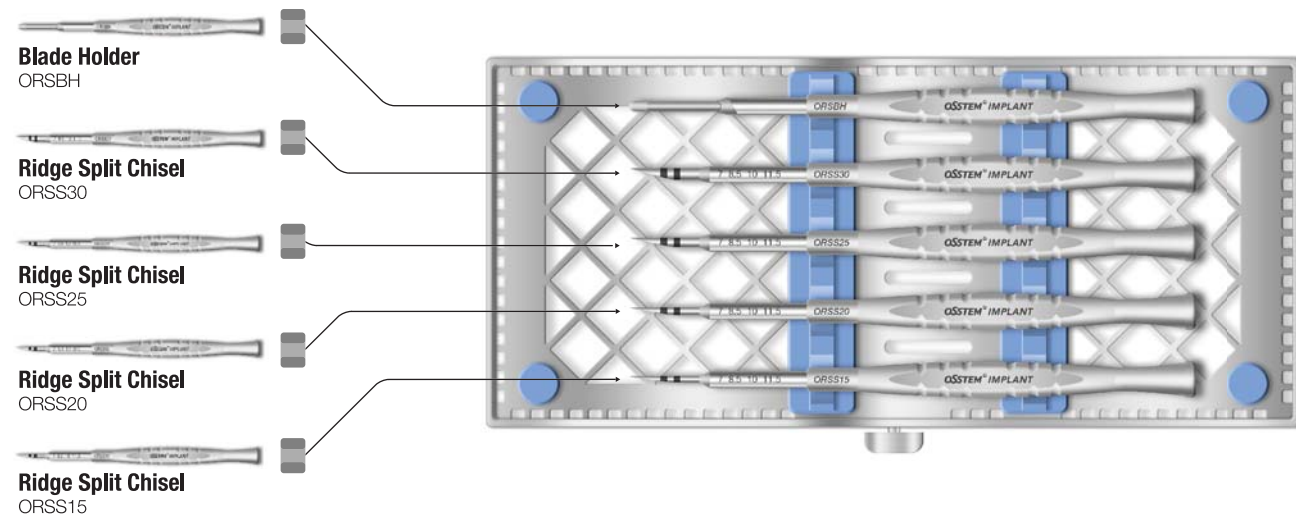

		(Unit : mm)				
Code	Spec.	Tip length	7	8.5	10	11.5
ORSS15	Thickness		1.1	1.27	1.5	1.5
	Width		4	4	4	4
ORSS20	Thickness		1.45	1.7	2.0	2.0
	Width		4	4	4	4
ORSS25	Thickness		1.8	2.15	2.5	2.5
	Width		4	4	4	4
ORSS30	Thickness		2.15	2.5	3.0	3.0
	Width		4	4	4	4

Ridge Split KIT Offset (ORSOK)

Offset

- Chisel : expands narrow alveolar ridge
- Blade holder : cuts poor bone quality using a bur, malletting is possible, use a #15 blade
- Components
 - Ridge split chisel : ORSO15, ORSO20, ORSO25, ORSO30
 - Blade holder : ORSBH

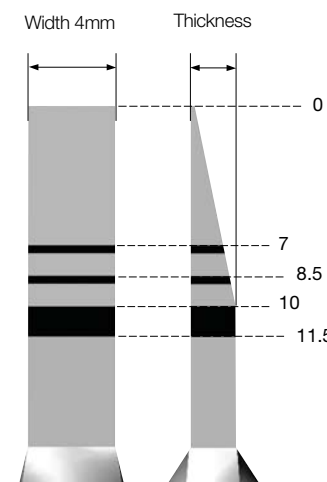
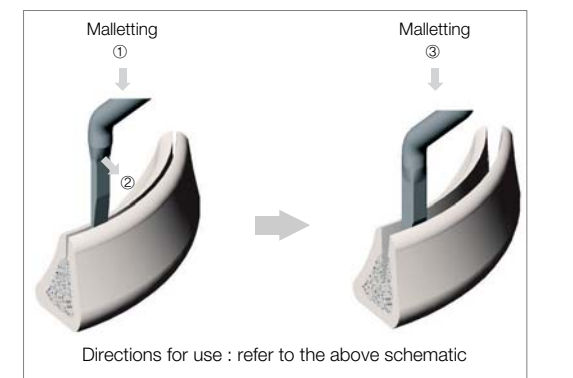
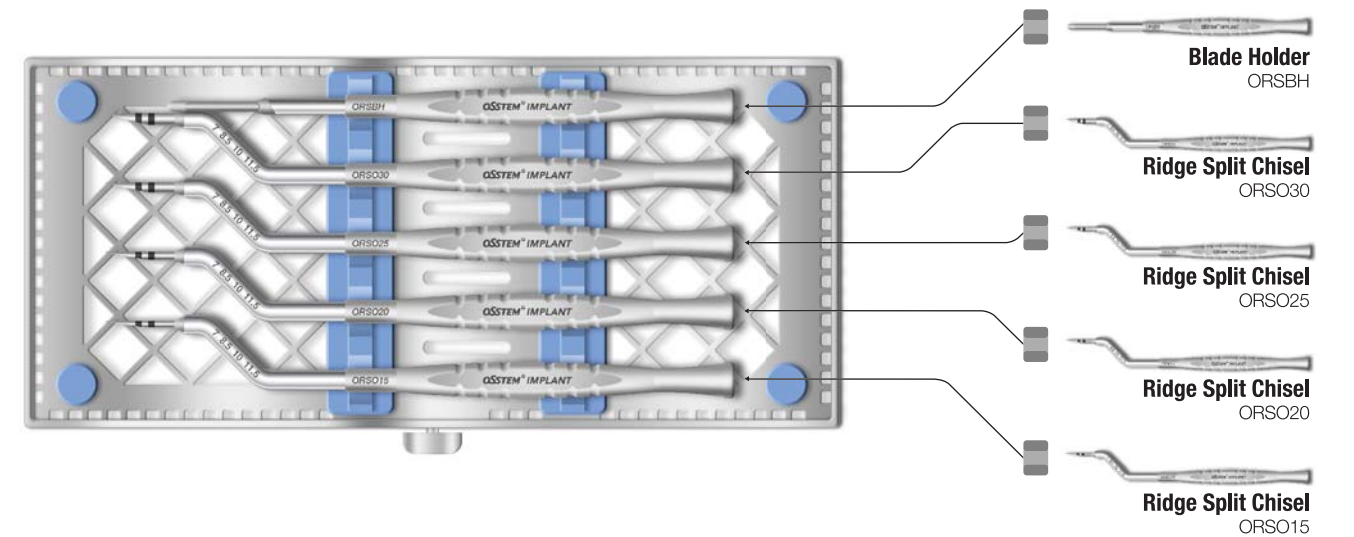

		(Unit : mm)				
Code	Spec.	Tip length	7	8.5	10	11.5
ORSO15	Thickness		1.1	1.27	1.5	1.5
	Width		4	4	4	4
ORSO20	Thickness		1.45	1.7	2.0	2.0
	Width		4	4	4	4
ORSO25	Thickness		1.8	2.15	2.5	2.5
	Width		4	4	4	4
ORSO30	Thickness		2.15	2.5	3.0	3.0
	Width		4	4	4	4

Instructions for Use (AUG. 2017, Ver. 5.5)

Description of Osstem implant system

Osstem Implant is a brand for implant materials for dental practices, and the fixture is made mainly of titanium. The abutment, prosthetic components and tools for the Osstem Implant system are compatible with the Osstem Implant fixture only. Using this product in combination with products from other manufacturers may cause various problems including loosening and fracture due to incomplete locking and compatibility issues. Refer to the manual or the catalogue or our website (www.osstem.com) for details. See the product label for the product code, specifications, manufacturing date, and expiration date.

Sterility

The fixture, cover screw, and healing abutment are cleansed and sterilized with gamma radiation. This product is a disposable sterilized medical device intended for one-time use. In order to prevent contamination or infection of the product or operated site, the product must be used using a sterilized instrument in a sterilized environment. Damaged products, products with open packaging, or expired products must be discarded due to potential risks of contamination, infection, or osseointegration failure. Re-sterilization or re-use of the product may result in infection, osseointegration failure, or implant damage due to reduced accuracy.

Storage condition

Keep the product in a dry place at room temperature(1~30°C). Keep away from direct sunlight.

General precautions

The surgical technology of dental implant involves an expert, complex procedure. Formal training is required to perform implant surgery. Careful considerations must be made before the operation in case of bone disorders (osteoporosis, osteomalacia) or metabolic disorders of the bone.

Precautions

Determine the local anatomy and suitability of the available bone for implant placement. Prepare the implant considering the expected situations and cautions. Excessive occlusal load may cause loosening or fracture of an implant. In order to avoid this condition, the implant must be placed in accurate location and direction considering the relationship between the implant and opposing dentition. Visual inspection as well as panoramic and periapical radiographs are essential to determine anatomical landmarks, occlusal conditions, periodontal status, and the adequacy of the bone. Adequate radiographs, direct palpation, and visual inspection of the implant site are necessary prior to implant surgery.

Procedural precautions

Osstem Implant System is for single and two stage surgical procedures. As much as possible, try to minimize damage to the cell tissue and surgical trauma, pay special attention to maintaining the temperature at the implant site and removal of the source of contamination and infection. All drills and taps must be sufficiently and continuously irrigated for cooling during use. Implant placement should be accomplished at very low speed (25-30 rpm) or manually. Excessive torque (greater than 55Ncm) in the fixture placement can have adverse effects such as partial fracture or necrosis of the bone. Placing an implant tilted by 30° or higher is not recommended due to possible fracture of implant. Immediate loading to the fixture right after the surgery should be avoided. The bone quality and initial stability after fixture placement are important elements in determining the appropriate loading time. Mini-diameter implant or implant with diameter of 4.0 or less and which integrates with angled abutment may be fractured due to limitations of structural rigidity. They are not recommended for use in a posterior area. The Ultra-Wide fixtures are intended to be used only to replace molar teeth and

that angled abutments are not to be used with the Ultra-Wide fixtures. Evaluate the quantity of bone and radiographs to assess any potential anatomical contraindications to use of the Ultra-Wide fixture. For the placement of the Short Implant (diameter is 5mm or more and length is shorter than 7mm) which is used on the molar region only, clinicians should closely examine the patients for any of the following conditions: 1) perimplant bone loss, 2) changes to implant's response to percussion, 3) radiographic changes in bone to implant contact along the implant's length. If a short implant shows mobility or greater than 50% bone loss, the implant should be considered for possible removal. And clinicians should consider a two-stage surgical approach, splinting a short implant to an additional implant, and placement of the widest possible fixture. Allow longer healing periods for osseointegration before fabrication of the prosthesis and avoid immediate loading. Products with diameter of 3.25mm or less must be used exclusively for mandibular anterior teeth in order to prevent fracture due to excessive occlusal load. It is recommended that you should avoid applying HA coated fixture to hard bone, and the insertion torque of the implant should be less than 35Ncm, because cracks or damages might occur in the coated layer during implant placement. The surfaces of CA and SOI have the same physical shape as the SA surface made through blasting and etching treatments. After the SA surface treatment, to prevent the products' exposure to the atmosphere, CA is stored in solution, whereas SOI is stored in water-film coating form; it is designed to maintain the chemically activated state of the SA surface. Thus, CA or SOI products should be implanted in the target region at least within 15 minutes of taking them out of the container.

Warning

The selection of inappropriate patients and surgical methods can cause implant failure or loss of bone supporting the implant. Osstem implants must not be used for purposes other than the recommended use and must not be remodeled. Implant mobility, bone loss, and chronic infection can result in failure of the implant surgery.

Indications for use

The Osstem Implant System is an artificial dental root that has been designed for use in dental implant treatment in order to recover lost teeth. The system is implanted via a surgical method in maxillary or mandibular bone to replace natural dental root. The Osstem Implant System is indicated for use in partially or fully edentulous mandibles and maxillae, in support of single or multiple-units restorations including; cemented retained, screw retained, or overdenture restorations, and final or temporary abutment support for fixed bridgework. It is intended for delayed loading. Products with diameter of 3.25mm or less must be used exclusively for mandibular anterior teeth in order to prevent fracture due to excessive occlusal load.

Side effects

A few problems may occur after the operation (loss of implant stability, damage of prosthesis, etc.). Deficient quality and quantity of the remaining bone, infection, allergic reaction, inferior oral hygiene or uncooperativeness of patient, implant mobility, partial deterioration of tissue, and improper position or arrangement of implants may cause the above mentioned problems.

Contraindications

- Contraindications include the following, but are not limited to:
- Patients with hemophilia or difficulties related to bone or wound treatment
 - Patients with uncontrollable diabetes, heavy smoker or alcoholic
 - Patients whose immunity system is inactive due to chemical therapy or radiation therapy
 - Patients with oral infection or inflammation (improper oral hygiene, bruxism)
 - Patients with untreatable occlusion/joint disorder, insufficient dental arch space
 - Any patient who is not suitable for an surgery

OSSTEM[®]
IMPLANT

■ **Manufacturer : Osstem Implant Co., Ltd.**
203, Geoje-daero, Yeonje-gu, Busan, Korea
TEL 82-51-850-2500 FAX 82-51-861-4693



2460



Sterilized using irradiation



Use by



Manufacture



DEUTSCHE OSSTEM GmbH.
Mergenthalerallee 35-37
65760 Eschborn, Germany
+49-(0)6196-777-5500



Do not reuse



Date of manufacture



Keep away from sunlight



Catalogue number



Non-Sterile



Keep dry



Batch code



Do not re-sterilize



Caution, Consult accompanying documents

Rx only

For USA only : Federal law restricts this device to sale by or on the order of a dentist

OSSTEM[®]
IMPLANT